

**ES60-5 SERIES
MAIN TRANSMISSION**



**Bulletin No. T210-ES60-5
Includes CM-59
October 1988**



For parts or service call us
Pro Gear & Transmission, Inc.



1 (877) 776-4600

(407) 872-1901

parts@eprogear.com

906 W. Gore St.

Orlando, FL 32805



MODEL ES60-5

CONTENTS, RATIO TABLE and IDENTIFICATION

T210-ES60-5

CONTENTS

RATIO TABLE	1
GEARS and RELATED PARTS	2-6
DRIVE GEAR GROUP	2-3
MAINSHAFT GROUP	2-3
COUNTERSHAFT GROUP	4-5
REVERSE IDLER SHAFT GROUP	4-5
DRIVE GEAR TABLE	6
COMPANION FLANGES and END YOKES	7
DRIVE GEAR BEARING CAP GROUP	8-9
CASE GROUP and RELATED PARTS	8-9
REAR BEARING CAP GROUP and RELATED PARTS	10-11
CASE TABLE	12
DRIVE GEAR BEARING CAP TABLE	12
CLUTCH HOUSING DIMENSIONS	13
SHIFTER HOUSING ASSEMBLY	14-15
REMOTE CONTROL ASSEMBLY	16-18
SHIFT LEVER and DOME ASSEMBLY	19
CLUTCH RELEASE CODE TABLE	20-21
OVERHAUL KITS—MAJOR and MINOR	22-23
TABULATED BILLS OF MATERIAL—ES60-5	24-31
TABULATED BILLS OF MATERIAL—CM59	32-45

RATIO TABLE

MODELS ES60-5 and MODELS 5952				
SPEEDS	MODELS			
	ES60-5A 5952-A	ES60-5C 5952-C	ES60-5D 5952-D	ES60-5E 5952-E
1st	7.17	7.17	7.17	6.54
2nd	3.88	4.21	3.88	3.54
3rd	2.39	2.54	2.11	1.93
4th	1.45	1.45	1.29	1.17
5th	1.00	1.00	1.00	1.00
Rev.	7.17	7.17	7.17	6.54

IDENTIFICATION

The Name Plate (NP-96) affixed to the LEFT side of the Transmission is stamped with information:

SERIAL

B/M No. MODEL

In requesting more information on these transmissions, furnish the B/M No. and the Serial Number.

Abbreviations used in this parts list include:

N.S. — Not Shown
N.S.S. — Not Sold Separately
N.R. — Not Required

MODEL ES60-5

T210-ES60-5

GEARS and RELATED PARTS

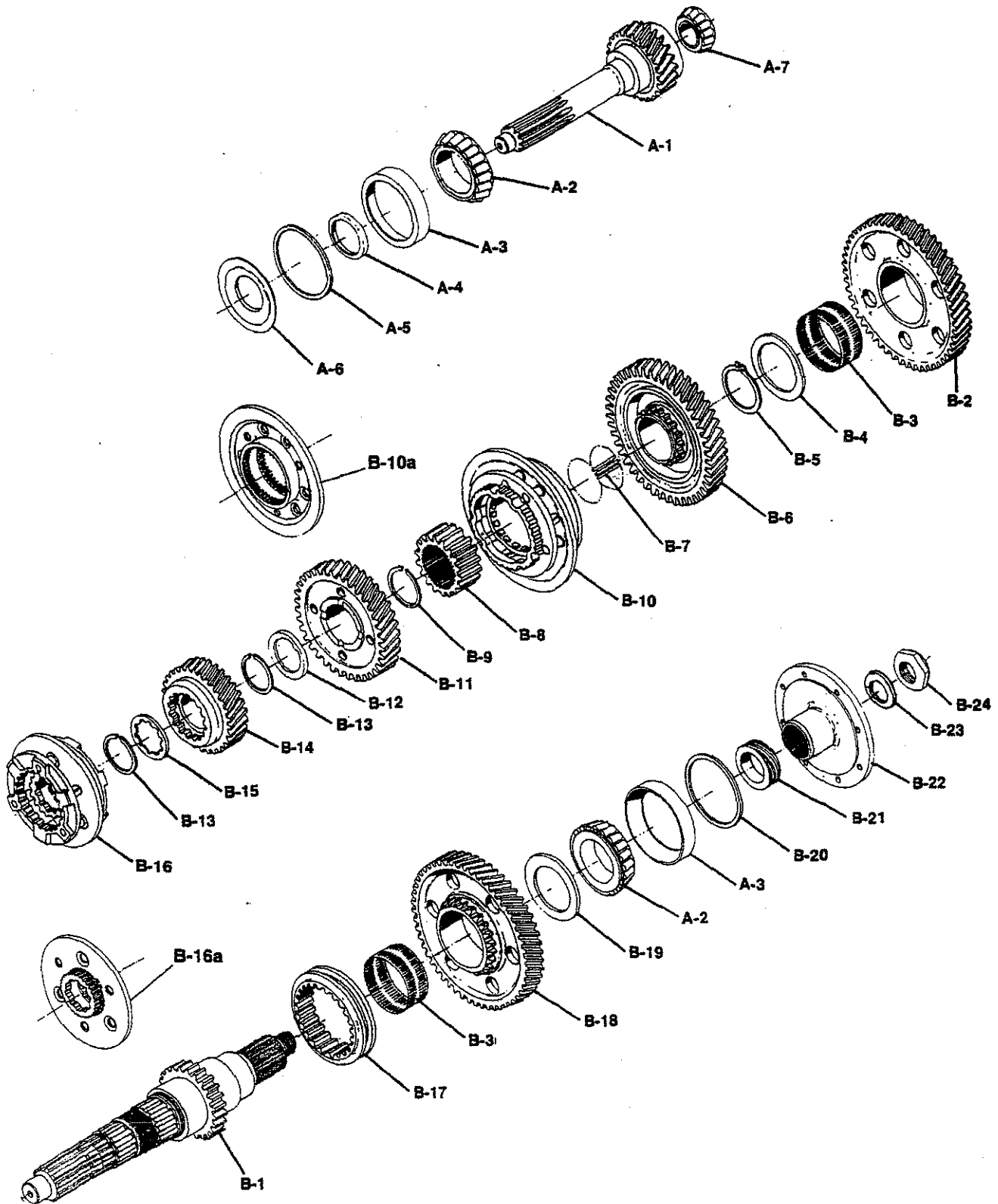

MODEL ES60-5

GEARS and RELATED PARTS

T210-ES60-5

Ref. No.	Part Number	Part Description	Qty.
DRIVE GEAR GROUP—INPUT			
A-1	See Tab Bills	Gear—main drive (see drive gear table page 6)	1
A-2	550930	Cone—main drive gear bearing	2
A-3	550929	Cup—main drive gear bearing	2
A-4*	47-468-2	Baffle—oil ring drive	1
A-5*	47-228-2-2	Spacer/Shim	1
A-6*	47-468-1	Baffle—bearing cap	1
A-7	550931	Cone—main drive gear pocket bearing	1
MAINSHAFT GROUP—OUTPUT			
B-1	53-362-3	Mainshaft	1
	53-362-8	Mainshaft—(1 $\frac{3}{4}$ "-10 spline industrial)	1
B-2	59-8-10	Gear—1st speed (42T)	1
B-3	550932	Bearing—1st & reverse gear needle assembly	2
B-4	330866	Thrust Washer—1st speed gear	1
B-5	27-381-5	Snap Ring	1
B-6		Gear—2nd speed	1
	59-8-8	(36T) for ES60-5A, ES60-5D, ES60-5E, 5952A, 5952D, 5952E	
	59-8-9	(37T) for ES60-5C, 5952C	
B-7	59-482-1-1X	Bearing Kit—mainshaft 2nd speed needle roller (61 needles)	1
B-8	59-466-3	Gear—2nd & 3rd speed clutch (40T)	1
B-9	46-381-1	Snap Ring	1
B-10	313536X	Synchronizer—2nd & 3rd speed (18T)	1
or			
B-10a	59-465-1	Clutch Collar (used in place of synchronizer) (40T)	1
B-11		Gear—3rd speed	1
	59-8-5	(35T) for ES60-5A, 5952A	
	59-8-7	(31T) for ES60-5C, 5952C	
	59-8-4	(33T) for ES60-5D, ES60-5E, 5952D, 5952E	
B-12	330818	Thrust Washer—3rd & 4th speed	1
B-13	53-381-2	Snap Ring	2
B-14		Gear—4th speed	1
	59-8-1	(27T) for ES60-5D, ES60-5E, 5952-D, 5952-E	
	59-8-2	(29T) for ES60-5A, ES60-5C, 5952-A, 5952-C	
B-15	1016-W	Thrust Washer—4th speed gear	1
B-16	313535X	Synchronizer—4th & 5th speed (31T/10T)	1
or			
B-16a	59-466-1-1X	Clutch Gear & Cam Plate (used in place of synchronizer and for industrial)	
B-17	47-465-1	Clutch Collar—1st & reverse	1
B-18	53-8-1	Gear—reverse (42T)	1
B-19	330867	Thrust Washer—reverse gear	1
B-20	313240-3X	Spacer & Shim Kit to adjust mainshaft end play	1
B-21	See Tab Bills	Gear—speedometer drive	1
or	53-37-1	Spacer—(use in place of speedometer drive gear)	1
B-22	See Tab Bills	Spacer—end yoke	1
B-23	53-205-1	Companion Flange or End Yoke—U-joint	1
B-24	501200	Washer—1 $\frac{1}{4}$ " flat	1
		Nut—1 $\frac{1}{4}$ "-18 hex	1

*Included in kit 313240-3X

N.S. — Not Shown

A.R. — As Required

PARTS LISTED IN THIS CATALOG MAY NO LONGER BE AVAILABLE, USE WITH TRANSMISSION SUPERSEDING LIST.

MODEL ES60-5

GEARS and RELATED PARTS

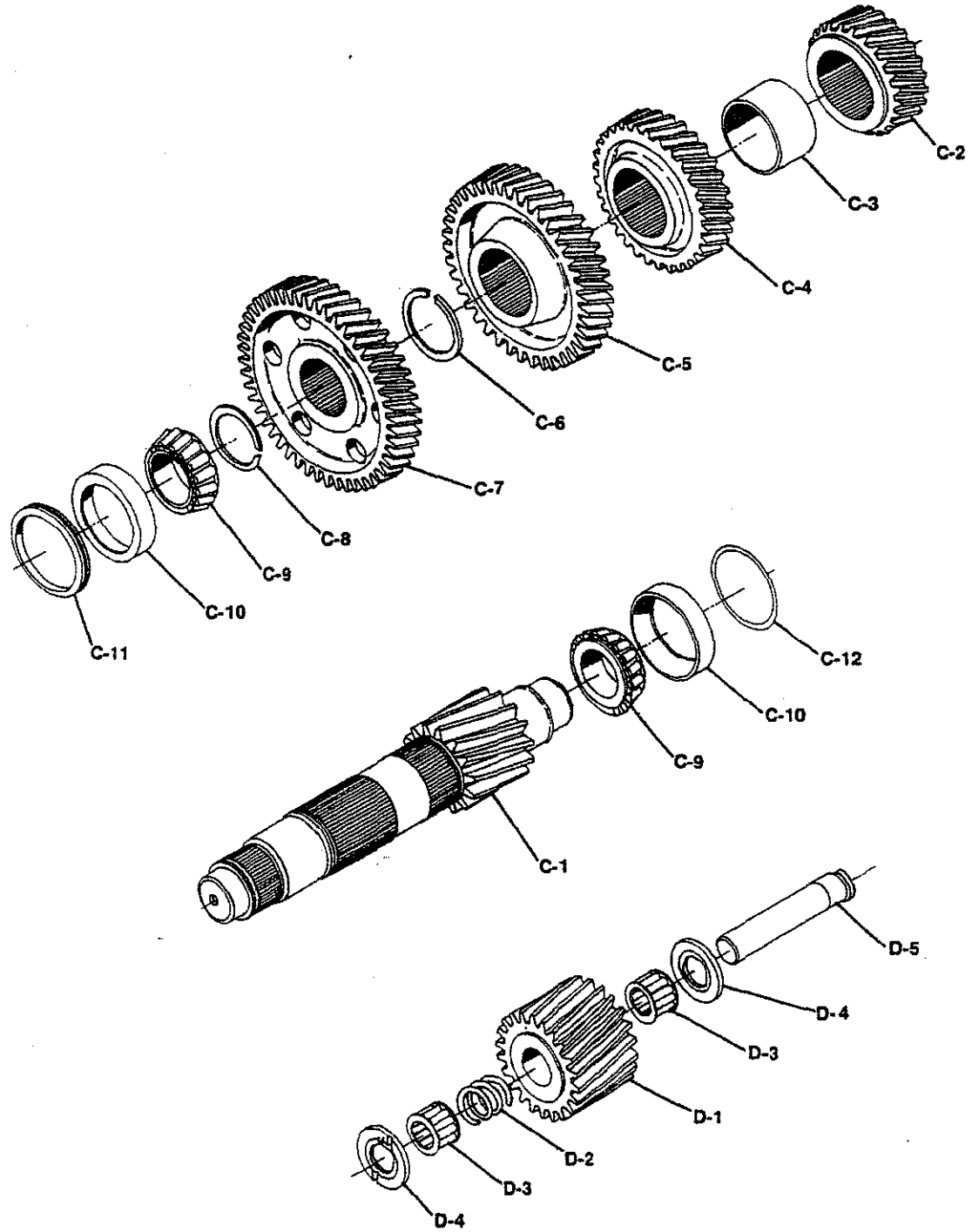

MODEL ES60-5

GEARS and RELATED PARTS

T210-ES60-5

Ref. No.	Part Number	Part Description	Qty.
COUNTERSHAFT GROUP			
C-1	59-30-3	Countershaft	1
	59-30-1	Countershaft (for rear P.T.O. drive).....	1
C-2	59-196-8	Gear—2nd speed	1
	59-196-9	(19T) for ES60-5A, ES60-5D, ES60-5E, 5952-A, 5952-D, 5952-E (18T) for ES60-5C, 5952-C	
C-3	59-37-1	Spacer—2nd & 3rd speed gear	1
C-4	59-196-4	Gear—3rd speed	1
	59-196-5	(32T) for ES60-5D, ES60-5E, 5952-D, 5952-E	
	59-196-7	(30T) for ES60-5A, 5952-A	
		(25T) for ES60-5C, 5952-C	
C-5	59-196-1	Gear—4th speed	1
	59-196-2	(43T) for ES60-5D, ES60-5E, 5952-D, 5952-E (41T) for ES60-5A, ES60-5C, 5952-A, 5952-C	
C-6	59-381-2	Snap Ring	1
C-7	59-1-1	Gear—drive	1
	59-1-2	(43T) for ES60-5E, 5952-E (43T) for ES60-5A, ES60-5C, ES60-5D, 5952-A, 5952-C, 5952-D	
	59-381-1	Snap Ring	1
C-8	550927	Cone—bearing	2
C-9	550375	Cup—bearing	2
C-10	47-37-3	Spacer—front bearing	1
C-11	313438X	Shim Kit to adjust Countershaft End Play	1
REVERSE IDLER SHAFT GROUP			
D-1	59-5-1	Gear—reverse idler (17T)	1
D-2	97-37-1	Spacer (spring)—bearing (spring)	1
D-3	550886	Bearing	2
D-4	974-W	Thrust Washer	2
D-5	63-60-1	Shaft—gear	1

PARTS LISTED IN THIS CATALOG MAY NO LONGER BE AVAILABLE, USE WITH TRANSMISSION SUPERSEDING LIST.

MODEL ES60-5

T210-ES60-5

DRIVE GEAR TABLE

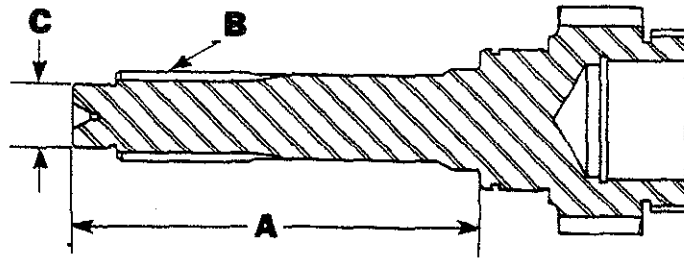

Teeth	A Length	B Spline Dia. Teeth	C- Pilot	Drive Gear Part No.
			Size	
21	8.844"	1½"-10	.9837"	59-35-3-1X
21	10.407"	1¾"-10	.9837"	59-35-9-1X
21	10.407"	1¾"-10	1.1800"	59-35-2-1X
21	8.532"	1½"-10	.9837"	59-35-4-1X
21	9.345"	—	.9837"	59-35-18-1X
21	9.782"	1¾"-10	1.1800"	59-35-10-1X
21	9.814"	1½"-10	.9837"	59-35-6-1X
21	10.298"	1½"-10	.9837"	59-35-7-1X
21	10.564"	1½"-10	.9837"	59-35-5-1X
23	8.844"	1½"-10	.9837"	59-35-1-1X
23	10.125"	1½"-10	.9837"	59-35-11-1X
23	10.407"	1½"-10	.9837"	59-35-17-1X
23	10.407"	1¾"-10	.9837"	59-35-16-1X
23	10.407"	1¾"-10	1.1800"	59-35-14-1X
23	9.564"	1½"-10	.9837"	59-35-12-1X
23	9.782"	1¾"-10	1.1800"	59-35-15-1X
23	10.403"	1½"-10	.9837"	59-35-13-1X

MODEL ES60-5

COMPANION FLANGES and END YOKES

T210-ES60-5

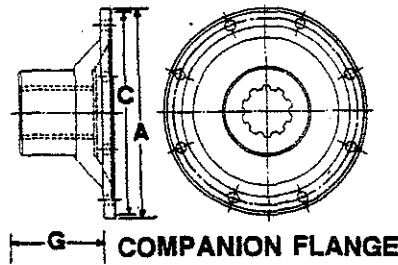

COMPANION FLANGE

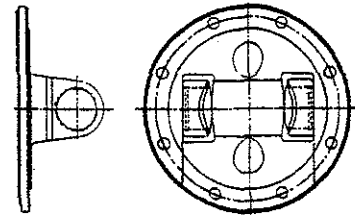

FLANGE YOKE

Companion Flanges

Joint Series	A Flange Diameter	Part No. Companion Flange	Part No. Companion Flange Assembly	G End of Hub to Flange Face Length	C Pilot Diameter F-Female M-Male	Brake Size
1480/1550	8"	53-106-1	—	5 ²¹ / ₃₂ "	M-6 ⁷ / ₁₆ "	9 x 3 or 12 x 4
1480/1550	Rectangular	53-106-2	—	2 ⁷ / ₈ "	F-3 ³ / ₄ "	—
1480/1550		4-1-6041	4-1-6051X			9 x 3
1610		5-1-6321	—			—
1710		6-1-5751	—			—

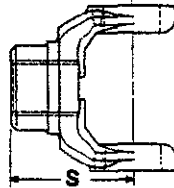

FULL ROUND

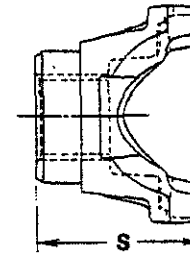

U-BOLT—BRG. STRAP—HALF ROUND

Series	Yoke Style	End Yoke Part Number	S End of Hub To Center Line Length	Momentary Joint Angle	Brake Size
1480	U-Bolt	3-4-8781	4 ¹¹ / ₆₄ "	22 ¹ / ₂ °	—
1480	Brg. Strap**	3-4-8931-2	3 ²⁹ / ₃₂ "	23 ¹ / ₂ °	—
1550	U-Bolt	4-4-4491	4 ¹ / ₆₄ "	21 ¹ / ₂ °	—
1550	Brg. Strap*	4-4-4491-1	4 ¹ / ₆₄ "	21 ¹ / ₂ °	—
1550	Brg. Strap**	4-4-4491-2	4 ¹ / ₆₄ "	21 ¹ / ₂ °	—
1550	Full Rnd.	4-4-4591			10 x 3
1550	U-Bolt	4-4-4601†	6 ²⁷ / ₆₄ "	22°	12 x 4
1550	U-Bolt	4-4-4611	4 ¹¹ / ₆₄ "	22 ¹ / ₂ °	—
1550	Brg. Strap*	4-4-4611-1	4 ¹¹ / ₆₄ "	22 ¹ / ₂ °	—
1550	Brg. Strap**	4-4-4611-2	4 ¹¹ / ₆₄ "	22 ¹ / ₂ °	—
1550	Half Rnd.	(A)4-4-6111-1X†	7 ¹ / ₃₂ "	22°	12 x 4
1610	Full Rnd.	5-4-6321	4"	19°	—
1610	Half Rnd.	5-4-6321-1	4"	19°	—
1610	Full Rnd.	5-4-6481	4 ¹¹ / ₆₄ "	22 ¹ / ₂ °	—
1610	Half Rnd.	5-4-6481-1	4 ¹¹ / ₆₄ "	22 ¹ / ₂ °	—
1610	Full Rnd.	5-4-6491†	6 ²¹ / ₃₂ "	22°	12 x 4
1610	Half Rnd.	(A)5-4-7611-1X†	7 ⁹ / ₁₆ "	22°	12 x 4
1710	Full Rnd.	6-4-7301	5 ¹ / ₄ "	33 ¹ / ₂ °	—
1710	Half Rnd.	6-4-7301-1	5 ¹ / ₄ "	33 ¹ / ₂ °	—

(A) Assembly Includes Brake Drum

† Flange Yokes

* With Tapped Holes

** With Thru Holes

MODEL ES60-5

T210-ES60-5

CASE GROUP and RELATED PARTS

Rear View of Clutch Housing
with Nodal Mount

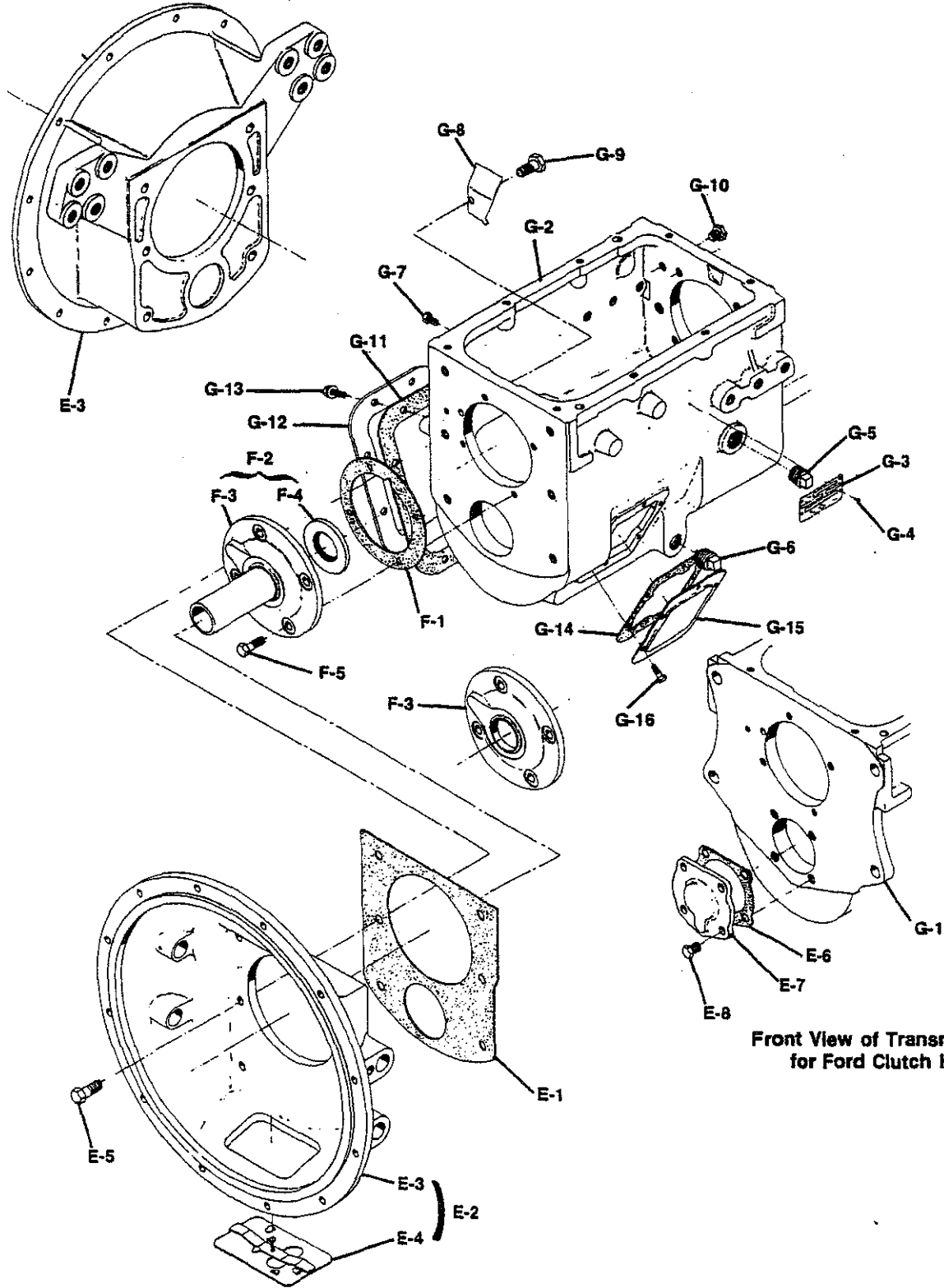

Front View of Transmission Case
for Ford Clutch Housings

MODEL ES60-5

CASE GROUP and RELATED PARTS

T210-ES60-5

Ref. No.	Part Number	Part Description	Qty.
CLUTCH HOUSING GROUP			
E-1	47-352-1	Gasket	1
E-2	See Tab Bills	Clutch Housing Assembly (See Table Page 13)	1
E-3	See Page 13	Clutch Housing	1
N.S.	128C-20	Bushing—(312256X & 312830X)	2
E-4	46-96-2-1X	Hand Hole Cover Assembly	1
E-5	See Page 13	Bolt—hex head self-locking	6
	545001	—Size 1/2"-13 x 1 1/4"	
	545001-1	1/2"-13 x 1 3/8"	
	545001-5	1/2"-13 x 1 1/8"	
	545001-6	1/2"-13 x 1 5/8"	
COUNTERSHAFT FRONT BEARING CAP (used with 59-15-5-2X case)			
E-6	47-223-5	Gasket—countershaft front bearing cap	1
E-7	60-22-28	Cap—countershaft front bearing	1
E-8	330801-1	Bolt—7/16"-14 x 7/8" hex head self-locking	4
DRIVE GEAR BEARING CAP GROUP			
F-1	47-223-1	Gasket	1
F-2	See Tab Bills	Cap & Seal Assembly (See Table Page 12)	1
F-3	N.S.S.	Cap	1
F-4	60-463-10	Oil Seal	1
F-5	545002-1	Bolt—3/8"-16 x 7/8" hex head self-locking	4
CASE GROUP			
G-1	See Tab Bills	Case Assembly (See Table Page 12)	1
G-2	N.S.S.	Case	1
G-3	NP-96	Nameplate	1
G-4	252-SP	Pin—nameplate	4
G-5	500100	Filler Plug	1
G-6	62-39-3	Drain Plug—magnetic square head	1
or	62-39-4	Drain Plug—magnetic (recessed head)	1
G-7	545002-10	Bolt—3/8"-16 x 1/2" hex head	2
G-8	330923	Oil Trough	1
G-9	545009	Bolt—5/16"-18 x 5/8" flanged head self-locking	1
G-10	307-D	Plug—1/2"-13 x 1/2" hex head	2
or	266-D	Plug—5/8"-11 x 7/16" hex head	2
N.S.	545089-1	Plug—9/16"-12 x 3/4" hex head, brake anchor bar	6
G-11	97-324-2-1X	Gasket Kit—8 bolt P.T.O. aperture cover	1
G-12	73-267-1	Cover—8 bolt P.T.O. aperture	1
G-13	545012	Bolt—7/16"-14 x 3/4" flanged hex head self-locking	8
G-14	97-324-1-1X	Gasket Kit—6 bolt P.T.O. aperture cover	1
G-15	50-267-2	Cover—6 bolt P.T.O. aperture	1
G-16	330800	Bolt—3/8"-16 x 3/4" hex head self-locking	6

N.S.S. — Not Sold Separately

N.S. — Not Shown

PARTS LISTED IN THIS CATALOG MAY NO LONGER BE AVAILABLE, USE WITH TRANSMISSION SUPERSEDING LIST.

MODEL ES60-5

T210-ES60-5 REAR, BEARING CAP GROUP and RELATED PARTS

H-1
See Chart

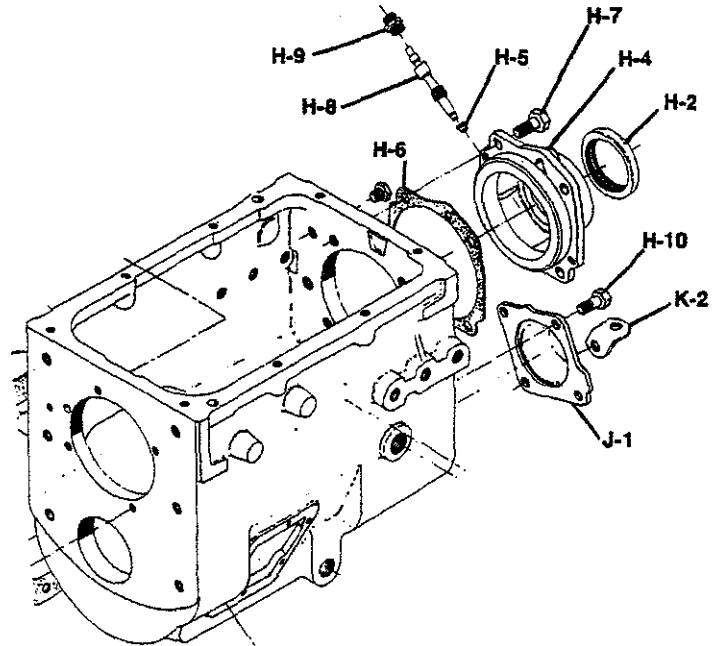

REAR BEARING CAP CHART

BEARING CAP ASSEMBLY INCLUDES

Part Number	Oil Seal	Casting Number	Speedometer Bushing	Gasket	Brake
H-1	H-2	—	H-5	H-6	—
53-19-12-4X	60-463-8	C53-19-6	60-475-1	47-223-3	—
53-19-3-4X	60-463-8	C53-19-4	30-475-1	53-223-1	DCM
53-19-1-4X	60-463-8	C53-19-2	30-475-1	47-223-3	—
53-19-22-2X	63-463-1	C53-19-23	—	63-223-7	—
53-19-7-4X	60-463-8	C53-19-8	60-475-1	53-223-1	12" x 3"
53-19-17-2X	63-463-1	C53-19-18	—	63-223-7	12" x 4"
53-19-15-2X	63-463-1	C53-19-16	—	63-223-7	9" & 10" x 3"
53-19-13-2X	63-463-1	C53-19-23	—	63-223-7	—
53-19-24-3X	60-463-8	C53-19-24	30-475-1	47-223-3	—
53-19-26-3X	60-463-8	C53-19-27	—	53-223-1	12" x 4"

MODEL ES60-5

REAR BEARING CAP GROUP and RELATED PARTS

T210-ES60-5

Ref. No.	Part Number	Part Description	Qty.
MAINSHAFT REAR BEARING CAP GROUP			
H-1	See Tab Bills	Cap Assembly—mainshaft rear bearing (See chart below)	1
H-2	60-463-8	Oil Seal—mainshaft rear bearing cap	1
	63-463-1	Oil Seal (Ford only)	1
H-4	N.S.S.	Cap—mainshaft rear bearing	1
H-5	See chart below	Bushing—speedometer	1
H-6	47-223-3	Gasket—mainshaft rear bearing cap	1
	53-223-1	Gasket—mainshaft rear bearing cap (IHC Bendix brake mounting)	1
	60-223-7	Gasket—mainshaft rear bearing cap (Ford only)	1
H-7	545001	Bolt— $\frac{1}{2}$ "-13 x $1\frac{1}{4}$ " hex head self locking	4
and	545008	Bolt— $\frac{5}{8}$ "-11 x $1\frac{1}{4}$ " hex head self locking (for brake cap)	2
H-8	See Tab Bills	Gear—speedometer driven	1
or	55-334-1	Plug—speedometer hole (use w/o driven gear)	1
N.S.	545021	Plug—speedometer outlet (electronic bearing caps)	1
H-9	55-454-1	Sleeve—Length $1\frac{1}{4}$ " speedometer driven gear	1
	44-473-1	Sleeve—Length 5" speedometer driven gear	1
	97-454-2-1X	Sleeve—Length $1\frac{1}{4}$ " speedometer driven gear (with seal)	1
H-10	545002-1	Bolt—countershaft rear bearing cap	4
COUNTERSHAFT REAR BEARING CAP GROUP			
J-1	59-22-1	Cap—countershaft rear bearing	1
K-2	330564-3	Lift Hook—countershaft rear bearing cap	1

MODEL ES60-5

CASE and FRONT BEARING CAP TABLE with Clutch Applications

T210-ES60-5

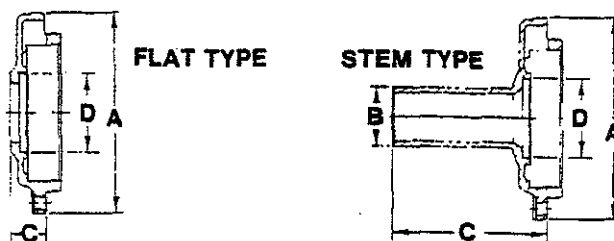

FRONT BEARING CAP CHART

A Outside Diameter	B Stem Diameter	C Length	D Oil Seal Bore Diameter	FRONT BEARING CAP	
				Casting Number	Assembly Includes Oil Seal F-2
FLAT TYPE				PULL TYPE RELEASE	
6 ³ / ₈ "	—	11 ¹ / ₃₂ "	2 ¹ / ₂ "	C47-19-2-1	53-19-11-1X
STEM TYPE —				PUSH TYPE RELEASE	
6 ³ / ₈ "	1.940"	6 ⁷ / ₃₂ "	2 ¹ / ₂ "	C47-19-83	47-19-74-1X
6 ³ / ₈ "	1.872"	5 ¹¹ / ₃₂ "	2 ¹ / ₂ "	C47-19-70	47-19-78-1X
6 ³ / ₈ "	1.872"	5 ¹⁹ / ₃₂ "	2 ¹ / ₂ "	C47-19-70	47-19-82-1X
7 ⁷ / ₃₂ "	1.940"	6 ⁷ / ₃₂ "	2 ¹ / ₂ "	C47-19-76	47-19-73-1X
6 ³ / ₈ "	1.872"	5 ²⁵ / ₃₂ "	2 ¹ / ₂ "	C47-19-70	47-19-77-1X
7 ¹ / ₈ "	1.808"	5 ⁵ / ₃₂ "	2 ¹ / ₂ "	C47-19-81	47-19-79-1X
6 ³ / ₈ "	2.246"	5 ¹³ / ₁₆ "	2 ¹ / ₂ "	C47-19-71	47-19-80-1X

CASE TABLE

Case Assembly G-1	Case (N.S.S.) Casting No.	Bolt ■G-9 Oil Trough G-8	(4 Pins) G-4 Name Plate G-3	OIL PLUG		CASE PLUG			Brake Anchor Bar Bolt or Plug N.S.
				Filler G-5	Drain G-6	Side G-7	Rear G-10	Rear G-10	
59-15-1-2X	C59-15-2	330923	NP-96	500100	62-39-4	—	—	—	545089-1
59-15-5-2X	C59-15-2	330923	NP-96	500100	62-39-4	—	—	—	545089-1
59-15-7-2X	C59-15-4-1	330923	NP-96	500100	62-39-3	545002-7	307D	266D	—
59-15-9-2X	C59-15-4	330923	NP-96	500100	62-39-3	—	307D	266D	545089-1
59-15-3-2X	C59-15-4	330923	NP-96	500100	62-39-3	—	307D	266D	545089-1
* 59-15-10-2X	C59-15-4	330923	NP-96	500100	62-39-3	545002-10	307D	—	545089-1

*This case assembly uses (3) 307D rear plug.

N.S. — Not Shown

■ Bolt G-9 part number is 545009

MODEL ES60-5

CLUTCH HOUSING DIMENSIONS

T210-ES60-5

SAE		
Size No.	A Pilot Dia.	B O.D.
1	20 ¹ / ₈ "	21 ³ / ₄ "
2	17 ⁵ / ₈ "	19 ¹ / ₄ "
3	16 ¹ / ₈ "	17 ³ / ₄ "

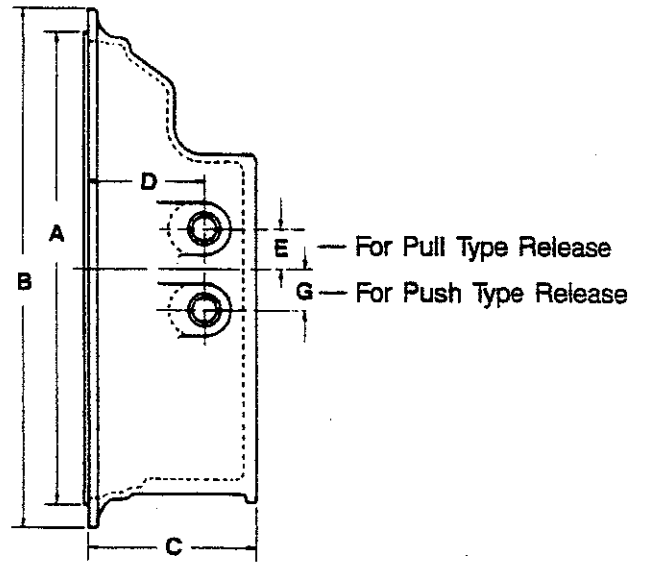

CLUTCH HOUSING				RELEASE SHAFT HOLE				Use With Bolt E-5	
Service Assembly No. E-2	Bushing Number	Casting Part Number	S A E	C Length	Dia.	C/L Front Face	D E C/L Above		G C/L Below
46-518-13-1X*	—	C46-518-14	2	4 ³ / ₄ "	—	—	—	—	545001-5
46-518-21-1X	—	C102C-477	3	5 ¹ / ₁₆ "	1"	3" 2 ¹⁷ / ₃₂ "	1 ¹ / ₂ " —	— 2 ⁵ / ₈ "	545001-5
46-518-22-1X	—	C102C-530-1	2	5 ¹ / ₁₆ "	1"	3" 2 ¹⁷ / ₃₂ "	1 ¹ / ₂ " —	— 2 ⁵ / ₈ "	545001-5
46-518-23	—	C46-518-18-1	2	5 ⁵ / ₈ "	1"	2 ³ / ₄ " 2 ³ / ₄ "	3" —	— 3"	545001
47-518-4-1X	—	Special	2	6 ⁵ / ₈ "	1"	3 ³ / ₄ "	1 ¹ / ₂ "	—	545001-1
47-518-5	—	C47-518-6	2	6 ¹ / ₂ "	1 ¹ / ₈ "	2 ¹⁹ / ₃₂ "	—	2 ¹ / ₂ "	545001-6
47-518-10-1X	—	C47-518-11	2	4 ³ / ₄ "	—	—	—	—	545001-5
312256X*	128C-20	C46-518-16	2	6"	1"	3 ⁵ / ₈ "	—	2 ¹ / ₂ "	545001-5
312830X	128C-20	C102C-530-1	2	5 ¹ / ₁₆ "	1"	2 ¹⁷ / ₃₂ "	—	2 ⁵ / ₈ "	545001-5

*Nodal Mount

PARTS LISTED IN THIS CATALOG MAY NO LONGER BE AVAILABLE, USE WITH TRANSMISSION SUPERSEDING LIST.

MODEL ES60-5

SHIFTER HOUSING ASSEMBLY

T210-ES60-5

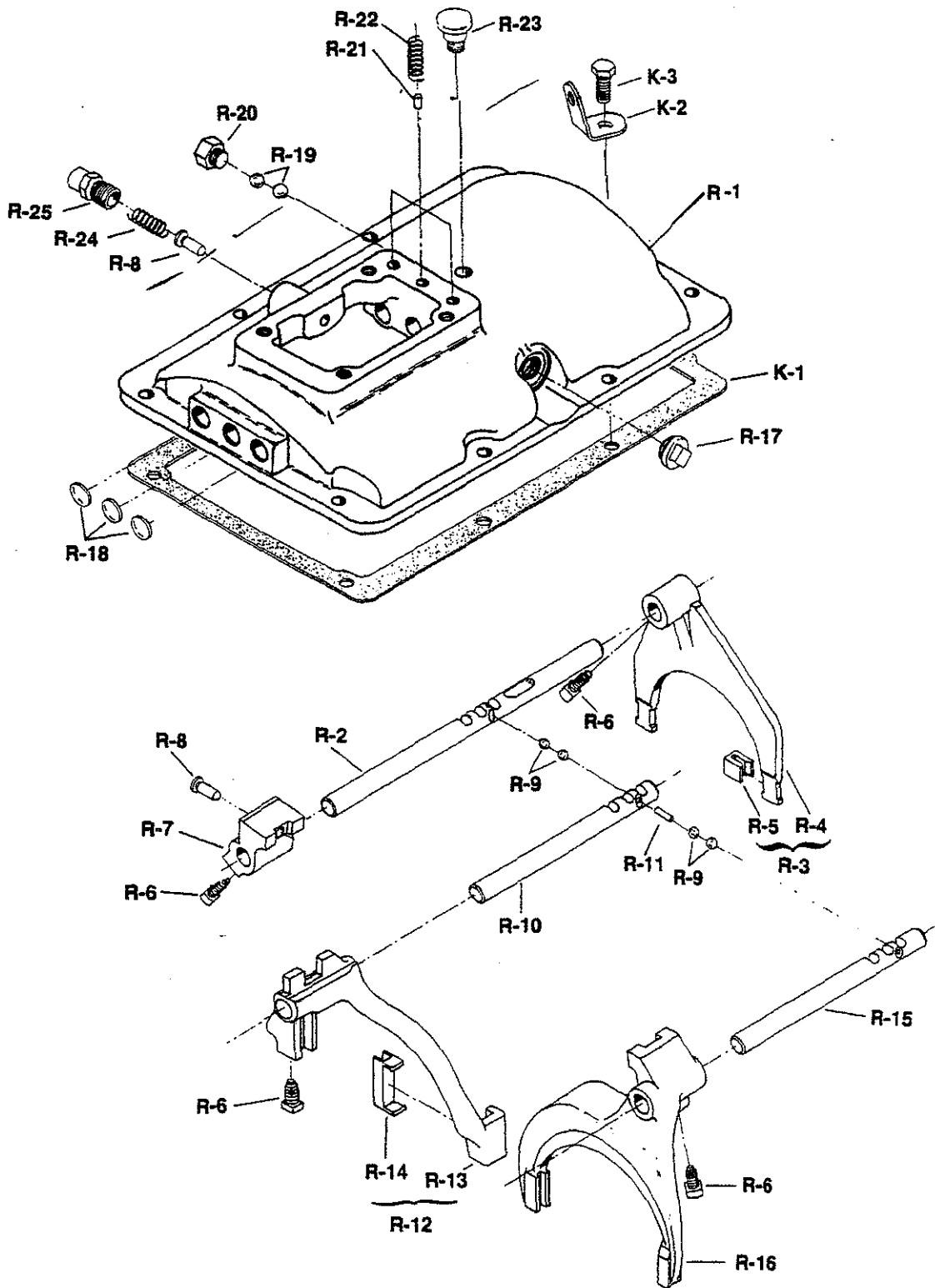

MODEL ES60-5

SHIFTER HOUSING ASSEMBLY

T210-ES60-5

Ref. No.	Part Number	Part Description	Qty.
	See Tab Bills	SHIFTER HOUSING ASSEMBLY	
R-1	47-16-1-1	Shifter Housing	1
R-2	47-67-1	Rod—reverse & 1st shift	1
R-3	59-66-1-1X	Fork & Clip Assembly—reverse & 1st shift	1
R-4	N.S.S.	Fork—reverse & 1st shift	1
R-5	46-486-2	Clip—shift fork	2
R-6	330639	Bolt— $\frac{3}{8}$ "-24 x $\frac{3}{4}$ " square head self-locking	4
R-7	53-354-1	Bracket—reverse & 1st shift rod	1
R-8	62-438-2	Pin—1st & reverse shift finger plunger	2
R-9	50-80-1	Ball—poppett and interlock	4
R-10	46-67-5	Rod—2nd & 3rd shift	1
R-11	277SP	Pin—interlock	2
R-12	53-66-3-1X	Fork—2nd & 3rd shift	1
R-13	N.S.S.	Shift Fork	1
R-14	53-486-1	Clip—shift fork	2
R-15	47-67-2	Rod—4th & 5th shift	1
R-16	53-66-1	Fork—4th & 5th shift	1
R-17	545021	Plug—interlock	1
R-18	330894	Expansion Plug— $\frac{3}{4}$ " (aluminum)	3
R-19	50-80-4	Ball—backup switch	2
R-20	330366	Plug—backup switch hole	1
R-21	50-80-1	Ball—shift rod poppet	3
R-22	47-72-1	Spring—shift rod poppet ball	3
R-23	312268	Breather Assembly	1
R-24	See Chart	Spring—shift finger plunger 1st & reverse	1
R-25	38P-1	Retainer—shift finger plunger 1st & reverse	1
PARTS LISTED BELOW ARE NOT INCLUDED IN ASSEMBLY			
K-1	47-155-1	Gasket—shifter housing	1
K-2	330564-1	Lift Hook—shifter housing	2
K-3	545002	Bolt— $\frac{3}{8}$ "-16 x 1" hex head self-locking	6
K-3	545002-4	Bolt— $\frac{3}{8}$ "-16 x $1\frac{1}{8}$ " hex head self-locking	2
N.S.	313262X	Neutral Safety Switch Actuator Kit (see tab bills)	

1st and Reverse Spring Chart (Ref. No. R-24)

Shifter Housing Assembly	Shifter Finger Plunger Spring	Spring Load	Free Length
47-16-1-8X	62-72-8	60#	$2\frac{1}{64}$ "
47-16-1-11X	30-72-6	28#	$2\frac{1}{8}$ "
47-16-1-13X	30-72-6	28#	$2\frac{1}{8}$ "
47-16-1-12X	82-72-3	15#	$2\frac{3}{8}$ "
47-16-1-16X	62-72-8	60#	$2\frac{1}{64}$ "
47-16-1-17X	62-72-8	60#	$2\frac{1}{64}$ "
47-16-1-18X	62-72-8	60#	$2\frac{1}{64}$ "

N.S.S. — Not Sold Separately

PARTS LISTED IN THIS CATALOG MAY NO LONGER BE AVAILABLE, USE WITH TRANSMISSION SUPERSEDING LIST.

MODEL ES60-5

REMOTE CONTROL ASSEMBLY

High Rod Type

T210-ES60-5

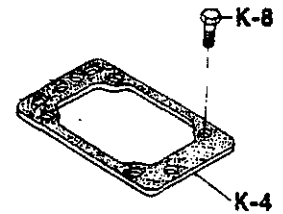
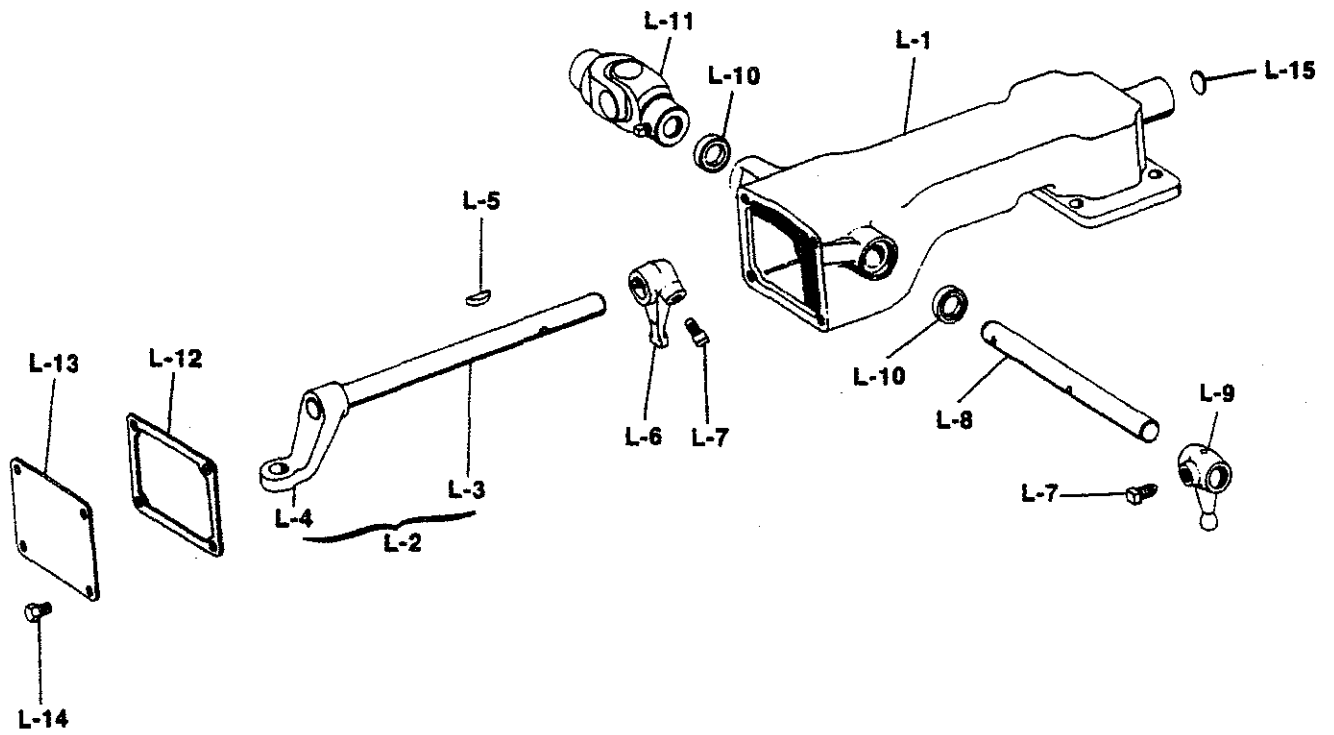

MODEL ES60-5

REMOTE CONTROL ASSEMBLY

High Rod Type

T210-ES60-5

Ref. No.	Part Number	Part Name	Remote Control Assembly	47-16-8-2X	47-16-8-3X	47-16-9-2X	47-16-12-2X
	See Tab Bills	COVER & JOINT ASSEMBLY—REMOTE CONTROL					
	47-16-8-1X	Cover Assembly (Casting No. 62-16-78)	1	1	1	1	1
	47-16-9-1X	Cover Assembly (Casting No. 62-16-78-1)	1	1			
	47-16-12-1X	Cover Assembly (Casting No. 62-16-128)			1		
L-1	N.S.S.	Remote Control Cover	1	1	1	1	1
N.S.	82-24-3	Bushing—remote control cover	4	4	4	4	4
L-2	310647X	Shift Finger Rod & Bracket Assembly	1	1			
	310879X	Shift Finger Rod & Bracket Assembly			1		
	312003X	Shift Finger Rod & Bracket Assembly				1	
L-3	N.S.S.	Rod—shift finger	1	1	1	1	1
L-4	N.S.S.	Bracket—shift finger rod	1	1	1	1	1
L-5	500007-19	Woodruff Key—No. 11 (part of assembly)	1	1	1	1	1
L-6	62-6-24	Finger—inner shift	1	1	1	1	1
L-7	545011	Bolt— $\frac{7}{16}$ "-20 x $\frac{7}{8}$ " hex head self-locking	2	2	2	2	2
L-8	82-65-5	Rod—remote control shift	1	1	1	1	1
L-9	82-6-7	Finger—outer shift	1	1	1	1	1
L-10	28P-19	Seal—remote control shift rod	2	2	2	2	2
L-11	10380-SF	U-Joint Assembly—control	1	1	1	1	1
L-12	82-118-1	Gasket—aperture cover	1	1	1	1	1
L-13	82-96-1	Aperture Cover	1	1	1	1	1
L-14	545005-1	Bolt— $\frac{5}{16}$ "-18 x $\frac{5}{8}$ " hex head self-locking	4	4	4	4	4
L-15	500166-16	Expansion Plug— $1\frac{1}{16}$ "	1	1	1	1	1
N.S.	311903X	Boot Kit—remote control		1			
N.S.	82-483-1	Boot		1			
N.S.	82-483-2	Boot—cup type		1			
N.S.	LW-3-9	Lockwire		3			
		PARTS LISTED BELOW ARE NOT INCLUDED IN ASSEMBLY					
K-4	62-155-7	Gasket—shifter housing to control cover	1	1	1	1	1
K-8	545028-4	Bolt— $\frac{7}{16}$ "-14 x $1\frac{1}{4}$ " hex head self-locking	4	4	4	4	4

N.S. — Not Shown
N.S.S. — Not Sold Separately

PARTS LISTED IN THIS CATALOG MAY NO LONGER BE AVAILABLE, USE WITH TRANSMISSION SUPERSEDING LIST.

MODEL ES60-5

REMOTE CONTROL ASSEMBLY Two Lever Type—Cable or Rod Control

T210-ES60-5

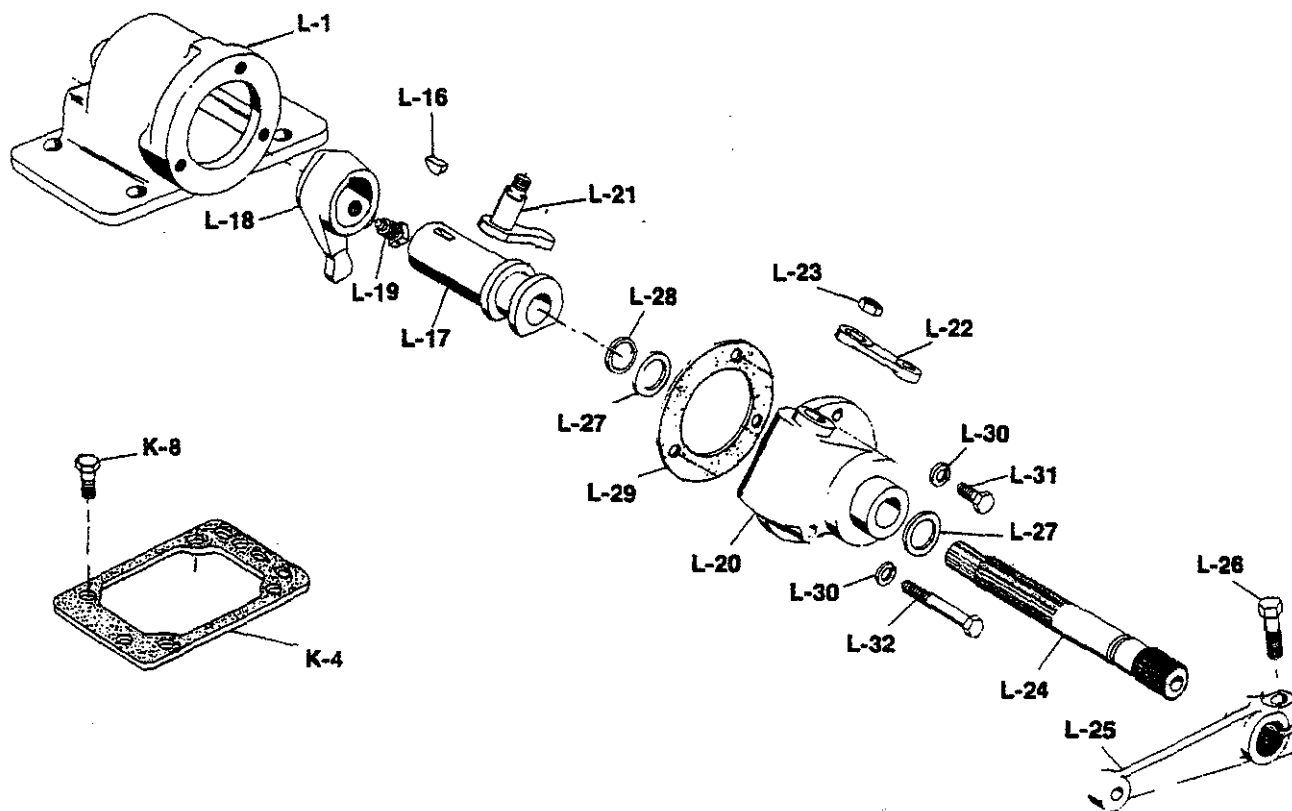

Ref. No.	Part Number	Part Description	Qty.
		REMOTE CONTROL COVER ASSEMBLY (See Tab Bills)	
L-1	311528-7X	Remote Control Cover	1
	47-16-13		1
L-16	500007-17	Woodruff Key #91	1
L-17	62-65-26	Shaft—inner shift finger	1
L-18	62-6-30	Shift Finger—inner	1
L-19	545063	Bolt— $\frac{7}{16}$ "-20 x $\frac{13}{16}$ " hex head self-locking	1
L-20	62-16-92	End Cover—remote control	1
L-21	310926X	Cam and Stud Assembly—selection lever	1
L-22	62-6-59	Lever—upper selection	1
L-23	500381-4	Nut— $\frac{7}{16}$ "-20	1
L-24	62-65-27	Rod—outer shift lever	1
L-25	47-6-1	Lever—outer shift	1
L-26	545002-7	Bolt— $\frac{3}{8}$ "-16 x $1\frac{1}{2}$ "	1
L-27	258-W	Washer—shift lever rod	2
L-28	62-381-13	Snap Ring	1
L-29	62-155-11	Gasket—end cover	1
L-30	500357-10	Lock Washer $\frac{5}{16}$ "	1
L-31	545005-2	Bolt— $\frac{5}{16}$ "-18 x $\frac{7}{8}$ "	2
L-32	500397-22	Bolt— $\frac{5}{16}$ "-18 x $2\frac{1}{2}$ "	1
		PARTS LISTED BELOW ARE NOT INCLUDED IN ASSEMBLY	
K-4	62-155-7	Gasket—shifter housing to control cover	1
K-8	545028-4	Bolt— $\frac{7}{16}$ "-14 x $1\frac{1}{4}$ " hex head self-locking	4

PARTS LISTED IN THIS CATALOG MAY NO LONGER BE AVAILABLE, USE WITH TRANSMISSION SUPERSEDING LIST.

MODEL ES60-5

SHIFT LEVER and DOME ASSEMBLY

T210-ES60-5

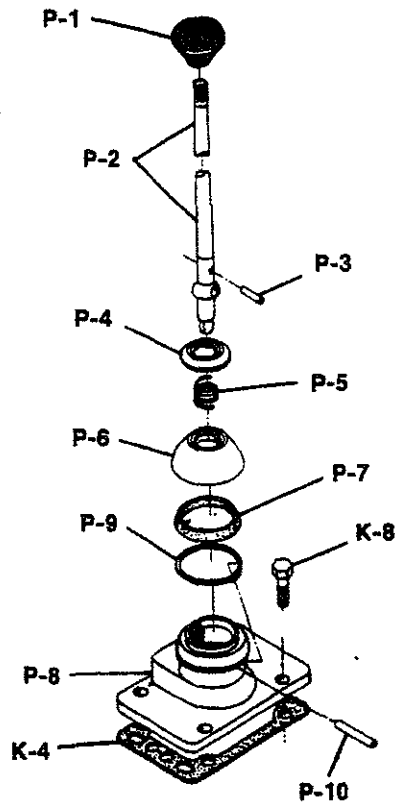

Ref. No.	Part Number	Part Description	47-16-5-38X	47-16-5-22X	47-16-5-43X	47-16-3-1X	47-16-3-25X	47-16-5-21X
		Lever and Dome Assembly—shift	1	1	1	1	1	1
P-1	See Tab Bills 39Q-27	Handle—shift lever	1					
P-2	25Q-1121	Shift Lever 26 $\frac{1}{4}$ " Straight				1		
	25Q-1122	Shift Lever 29 $\frac{1}{4}$ " Straight					1	
	25Q-1621	Shift Lever 30" Straight	1					1
	25Q-1537	Shift Lever		1				
	25Q-2464	Shift Lever—lower end (3.5")			1			
N.S.	55Q-5	Grommet—shift lever (boot)	1	1				1
	47-16-3X	Dome Assembly—2 $\frac{5}{8}$ " overall height				1	1	
	47-16-5X	Dome Assembly—3 $\frac{5}{8}$ " overall height	1	1	1			1
P-3	286-SP	Pin—shift lever collar	1	1	1	1	1	1
P-4	55Q-7	Collar—compression	1	1	1	1	1	1
P-5	56Q-25	Spring—compression	1	1	1	1	1	1
P-6	54Q-13	Cup—compression	1	1	1	1	1	1
P-7	69Q-6	Washer—friction	1	1	1	1	1	1
P-8	47-16-3	Dome—shift lever				1	1	
	47-16-5	Dome—shift lever	1	1	1			1
P-9	62-381-7	Snap Ring—rock shaft	1	1	1	1	1	1
P-10	53Q-15	Shaft—shift lever rock	1	1	1	1	1	1
		PARTS LISTED BELOW ARE NOT INCLUDED IN ASSEMBLY						
K-4	62-155-7	Gasket—dome to shifter housing	1	1	1	1	1	1
K-8	545002	Screw— $\frac{7}{16}$ "-14 x $1\frac{1}{8}$ " hex head self-locking	4	4	4	4	4	4
N.S. — Not Shown								

PARTS LISTED IN THIS CATALOG MAY NO LONGER BE AVAILABLE, USE WITH TRANSMISSION SUPERSEDING LIST.

MODEL ES60-5

T210-ES60-5

CLUTCH RELEASE CODE TABLE

Ref.Code See Tab Bill	CR-7 Yoke *	Shaft		CR-6 Pedal Adjusting Arm	Ref.Code See Tab Bill	CR-7 Yoke *	Shaft		CR-6 Pedal Adjusting
		CR-1 Short	CR-2 Long				CR-1 Short	CR-2 Long	
1	105C-64	106C-1142	106C-1047	310233X	58	105C-137	106C-1141	106C-1169	31023
2	105C-64	106C-1185	106C-438	—	59	105C-137	106C-1185	106C-438	—
3	105C-64	106C-1185	106C-939	310233X	60	105C-137	106C-1185	106C-617	310233X
4	105C-64	106C-1185	106C-1046	310233X	61	105C-137	106C-1185	106C-839	310233X
5	105C-64	106C-1185	106C-1047	310233X	62	105C-137	106C-1185	106C-939	310233X
6	105C-64	106C-1185	106C-1047	47-526-1-1X	63	105C-137	106C-1185	106C-939	310473X
7	105C-64	106C-1544	106C-839	310233X	64	105C-137	106C-1185	106C-953	310473X
					65	105C-137	106C-1185	106C-1046	310233X
8	105C-68	106C-1142	106C-438	—	66	105C-137	106C-1185	106C-1046	310473X
9	105C-68	106C-1142	106C-617	—	67	105C-137	106C-1185	106C-1047	310233X
10	105C-68	106C-1142	106C-617	310233X	68	105C-137	106C-1185	106C-1083	310233X
11	105C-68	106C-1142	106C-839	310233X	69	105C-137	106C-1185	106C-1094	—
12	105C-68	106C-1142	106C-939	310233X	70	105C-137	106C-1185	106C-1094	310233X
13	105C-68	106C-1142	106C-1046	310233X	71	105C-137	106C-1185	106C-1123	—
14	105C-68	106C-1142	106C-1047	310233X	72	105C-137	106C-1185	106C-1123	310233X
15	105C-68	106C-1278	106C-438	—	73	105C-137	106C-1185	106C-1367	—
					74	105C-137	106C-1185	106C-1367	310233
16	105C-117	106C-1071	106C-939	310233X	75	105C-137	106C-1185	106C-1375	310873X
17	105C-117	106C-1071	106C-1094	310233X	76	105C-137	106C-1185	106C-1515	—
18	105C-117	106C-1142	106C-939	310233X	77	105C-137	106C-1185	106C-1529	—
19	105C-117	106C-1185	106C-438	—	78	105C-137	106C-1185	330610-5	—
20	105C-117	106C-1185	106C-617	310233X	79	105C-137	106C-1216	106C-617	310233X
21	105C-117	106C-1185	106C-839	47-526-1-1X	80	105C-137	106C-1278	106C-438	—
22	105C-117	106C-1185	106C-939	310233X	81	105C-137	106C-1278	106C-588	—
23	105C-117	106C-1185	106C-953	310873X	82	105C-137	106C-1278	106C-588	310233X
24	105C-117	106C-1185	106C-960	310233X	83	105C-137	106C-1278	106C-617	310233X
25	105C-117	106C-1185	106C-1046	310233X	84	105C-137	106C-1278	106C-939	310233X
26	105C-117	106C-1185	106C-1047	310233X	85	105C-137	106C-1278	106C-939	310873X
27	105C-117	106C-1185	106C-1083	—	86	105C-137	106C-1278	106C-960	310233X
28	105C-117	106C-1185	106C-1083	310233X	87	105C-137	106C-1278	106C-1046	—
29	105C-117	106C-1185	106C-1083	310473X	88	105C-137	106C-1278	106C-1046	310233X
30	105C-117	106C-1185	106C-1094	310233X	89	105C-137	106C-1278	106C-1047	—
31	105C-117	106C-1185	106C-1094	310873X	90	105C-137	106C-1278	106C-1047	310233X
32	105C-117	106C-1185	106C-1169	310233X	91	105C-137	106C-1278	106C-1083	310233
33	105C-117	106C-1185	106C-1315	—	92	105C-137	106C-1278	106C-1094	310233X
34	105C-117	106C-1185	106C-1315	310233X	93	105C-137	106C-1278	106C-1375	310233X
35	105C-117	106C-1185	106C-1315	47-526-1-1X	94	105C-137	106C-1278	106C-1422	310233X
36	105C-117	106C-1185	106C-1417	310233X	95	105C-137	106C-1278	106C-1529	—
37	105C-117	106C-1185	106C-1417	310873X	96	105C-137	106C-1360	106C-1083	—
38	105C-117	106C-1185	106C-1490	310233X	97	105C-137	106C-1360	106C-1422	310233X
39	105C-117	106C-1278	106C-939	310233X	98	105C-137	106C-1375	106C-438	310233X
40	105C-117	106C-1278	106C-960	310873X	99	105C-137	106C-1498	106C-438	—
41	105C-117	106C-1278	106C-1047	310233X	100	105C-137	106C-1498	106C-617	310233X
42	105C-117	106C-1278	106C-1094	310233X	101	105C-137	106C-1498	106C-617	310473X
43	105C-117	106C-1278	106C-1315	310233X	102	105C-137	106C-1498	106C-939	310233X
44	105C-117	106C-1278	106C-1367	310233X	103	105C-137	106C-1498	106C-939	310473X
45	105C-117	106C-1360	106C-1083	310233X	104	105C-137	106C-1498	106C-953	310233X
46	105C-117	106C-1360	106C-1315	310233X	105	105C-137	106C-1498	106C-959	310233X
47	105C-117	Thru Shaft	106C-1550	—	106	105C-137	106C-1498	106C-1046	310233X
48	105C-117	Thru Shaft	106C-1558	—	107	105C-137	106C-1498	106C-1047	—
					108	105C-137	106C-1498	106C-1047	310233
49	105C-124	106C-1185	106C-438	—	109	105C-137	106C-1498	106C-1083	310233X
50	105C-124	Thru Shaft	106C-1566	310233X	110	105C-137	106C-1498	106C-1094	—
51	105C-124	Thru Shaft	106C-1566	310473X	111	105C-137	106C-1498	330610-11	310233X
52	105C-124	Thru Shaft	106C-1566	310873X	112	105C-137	330601-1	106C-939	310233X
52A	105C-124	Thru Shaft	49-510-1	310233X					
53	105C-132	106C-1185	106C-1047	310233X	113	85-509-3	106C-1360	106C-1417	310233X
54	105C-132	106C-1185	106C-1083	310233X	114	85-509-3	Thru Shaft	106C-1578	310233X
55	105C-132	106C-1185	106C-1417	310873X	115	85-509-3	Thru Shaft	106C-1578	310873X
56	105C-132	106C-1185	46-510-9	—					
57	105C-132	106C-1278	46-510-9	—	116	312916	Thru Shaft	97-510-2	—

■ Use Clutch Release Bearing 7743X

★ CLUTCH RELEASE YOKE ATTACHING PARTS—Use one KEY 10-30, two SCREWS 330231 and two LOCK WASHERS 500356-12

PARTS LISTED IN THIS CATALOG MAY NO LONGER BE AVAILABLE, USE WITH TRANSMISSION SUPERSEDING LIST.

MODEL ES60-5

CLUTCH RELEASE CODE TABLE

T210-ES60-5

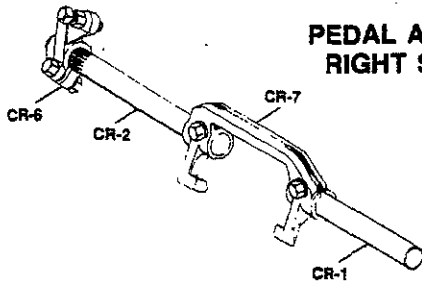

**PEDAL ADJUSTING ARM
RIGHT SIDE—310473X**

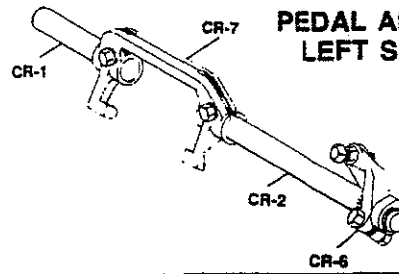

**PEDAL ADJUSTING ARM
LEFT SIDE—310233X**

CR-1 SHORT SHAFT

Part No.	Length
106C-1071	4.062"
106C-1141	5.125"
106C-1142	6.125"
106C-1185	5.750"
106C-1216	4.750"
106C-1278	4.812"
106C-1360	5.312"
106C-1375	6.781"
106C-1498	6.500"
106C-1544	7.000"
330601-1	6.250"

CR-2 LONG SHAFT (Cont'd)

Part No.	Type	Length
106C-1083	RS-8	7.969"
106C-1094	RS-8	8.469"
106C-1123	RS-8	12.968"
106C-1169	RS-8	9.125"
106C-1315	RS-8	7.625"
106C-1367	RS-8	10.312"
106C-1375	RS-8	6.781"
106C-1417	RS-8	7.250"
106C-1422	RS-8	7.500"
106C-1490	RS-8	16.000"
106C-1515	RS-5	11.375"
106C-1529	RS-5	8.312"
330610-5	RS-8	9.469"
330610-11	RS-8	10.750"
46-510-9	RS-5	7.125"



CR-2 LONG SHAFT

Part No.	Type	Length
106C-438	RS-5	14.000"
106C-588	RS-5	7.000"
106C-617	RS-8	10.469"
106C-839	RS-8	11.469"
106C-939	RS-8	10.000"
106C-953	RS-8	9.750"
106C-959	RS-8	11.968"
106C-960	RS-8	8.719"
106C-1046	RS-8	8.968"
106C-1047	RS-8	9.469"

CR-6 PEDAL ADJ. ARM

310233X	For Left Side Mtg.
310473X	For Right Side Mtg.
47-526-1-1X	Lever Type 7/8"
310873X	Lever Type 7/4"
■Lever type can be used on either right or left side.	

THRU SHAFT (used with Push Type Clutch)

Part No.	Type	Length
106C-1566	Splined	19.125"
106C-1550	Keyed	16.375"
106C-1558	Keyed	19.000"
106C-1578	Splined	19.500"
49-510-1	Keyed	19.120"
97-510-2	Splined	19.313"

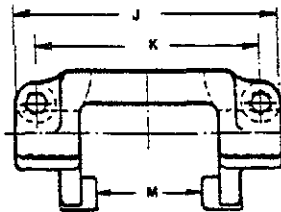

CLUTCH RELEASE YOKES

CR-7	Forging No.	Used With	Type	J	K	M
105C-64	F105C64	Spicer 15 1/2" SP	Pull	8.000"	6.500"	4.895"
105C-68	F105C99	Spicer 14" SP	Pull	7.125"	5.750"	4.132"
105C-117 ¹	F105C118	Spicer & Others	Push	8.375"	7.000"	4.885"
105C-124	F105C125	Spicer AL & AR	Push	3.750"	2.125"	2.885"
105C-132 ²	F105C118	Spicer & Others	Push	8.375"	7.000"	4.885"
105C-137	F105C138	Spicer 13" and	Pull	8.000"	6.500"	4.895"
	C105C138	14" 2P				
85-509-3 ³	F105C118	Spicer & Others	Push	8.375"	7.000"	4.885"

- ¹Machined washer surface on yoke front
- ²Machined washer surface on yoke rear (for clearance)
- ³Same as ¹ above except contains spring holes in lugs
- Use 7743X Clutch Release Bearing

- * CLUTCH RELEASE YOKE ATTACHING PARTS—
Use one KEY 10-30, two SCREWS 330231 and two LOCK WASHERS 500356-12
- NOTE: When changing from a two plate to single plate clutch or vice versa, a different bearing cap will be required.

PARTS LISTED IN THIS CATALOG MAY NO LONGER BE AVAILABLE, USE WITH TRANSMISSION SUPERSEDING LIST.

MODEL ES60-5

BASIC OVERHAUL KITS

T210-ES60-5

Part Number	Part Description	Qty.
MAJOR OVERHAUL KIT		
313400-68X	MAJOR OVERHAUL KIT	1
500008-37	Woodruff Key—#F	4
53-205-1	Washer—mainshaft	1
501200	Nut—mainshaft output	1
313401-13X	Thrust Washer Kit	1
313429-6X	Shifter Housing Small Parts Kit	1
313432-31X	Minor Overhaul Kit	1
MINOR OVERHAUL KIT (Included in Major Overhaul Kit)		
313432-31X	MINOR OVERHAUL KIT	1
BEARINGS		
550375	Countershaft—cup	2
550927	Countershaft—cone	2
550886	Reverse Idler Shaft	2
550929	Drive Gear & Mainshaft Rear—cup	2
550930	Drive Gear & Mainshaft Rear—cone	2
550931	Drive Gear—pocket	1
550932	1st & Reverse Mainshaft Needle Bearing	2
59-482-1-1X	Needle Roller Bearing & Spacer Kit	1
60-463-10-1X	Oil Seal Kit—drive gear bearing cap	1
60-463-8	Oil Seal Kit—mainshaft rear bearing cap	1
63-463-1	Oil Seal Kit—mainshaft rear—Ford only	1
545077	Bearing Lubricant	1
545080	Locite	1
2770	Bearing Lube Instruction	1
2783	Locite Application for Mainshaft Nut	1
312475-28X	Gasket Kit	1
313024-18X	Snap Ring Kit	1
313240-3X	Baffle & Shim Kit—drive gear	1
313438X	Shim Kit—countershaft rear	1
59-482-1-1X	Bearing Kit—mainshaft 2nd speed needle roller	1
2360	Service Manual	1
No. 2	Spicer Service Topics	1

PARTS LISTED IN THIS CATALOG MAY NO LONGER BE AVAILABLE, USE WITH TRANSMISSION SUPERSEDING LIST.

MODEL ES60-5

T210-ES60-5

Part Number	Part Description	Qty.
	(Included in MAJOR OVERHAUL KIT)	
313401-13X	Thrust Washer Kit	1
974-W	Countershaft—reverse idler	2
1016-W	Mainshaft—4th speed	1
330818	Mainshaft—3rd & 4th speed	1
330866	Mainshaft—1st speed	1
330867	Mainshaft—reverse	1
313429-6X	Shifter Housing Small Parts Kit	1
277-SP	Interlock Pin	1
50-80-1	Shift Rod Poppet & Interlock Ball	7
50-80-4	Backup Switch Ball	2
62-438-2	Plunger—1st & reverse	2
47-72-1	Spring—shift rod poppet	3
62-72-8	Spring—shift finger plunger 1st & reverse	1
	(Included in MAJOR and MINOR OVERHAUL KITS)	
312475-28X	GASKET KIT	1
82-118-1	Remote Control—aperture cover	1
47-155-1	Shifter Housing	1
62-155-7	Control cover	1
47-223-1	Drive Gear Bearing Cap	1
47-223-2	Countershaft Rear Bearing Cap	1
47-223-3	Mainshaft Rear Bearing Cap	1
47-223-4	Mainshaft Rear Bearing Cap—for brake mounting	1
47-223-5	Countershaft Front Bearing Cap	1
53-223-1	Mainshaft Rear Bearing Cap—for brake mounting	1
63-223-7	Mainshaft Bearing Cap—for Ford only	1
47-352-1	Clutch Housing	1
97-324-1-1X	P.T.O. (6 Holes) Kit	1
97-324-2-1X	P.T.O. (8 Holes) Kit	1
313024-18X	SNAP RING KIT	1
27-381-5	Mainshaft	1
46-381-1	Countershaft & Mainshaft	2
53-381-2	Mainshaft	2
59-381-1	Countershaft	1
313240-3X	BAFFLE & SHIM KIT—mainshaft	1
47-228-1-1	Adjusting Shim—mainshaft rear	9
47-228-2-2	Shim—mainshaft front	1
47-228-2-10	Spacer—mainshaft rear	1
47-468-1	Baffle—bearing cap front	1
47-468-2	Baffle—oil ring drive gear	1
2789	Bulletin—baffle & shim kit	1
2759	Bulletin—drive gear replacement	1
313438X	SHIM KIT—countershaft rear	1
47-228-3-1	Shim—rear bearing	4

PARTS LISTED IN THIS CATALOG MAY NO LONGER BE AVAILABLE, USE WITH TRANSMISSION SUPERSEDING LIST.

MODEL ES60-5

T210-ES60-5

TABULATED BILLS OF MATERIAL

Tab No.	Used By	For Use With Clutch 13" or 14" Single or 2PL	CLUTCH HOUSING			Main Drive Gear A-1	Drive Gear Bearing Cap F-2	Main Case Assembly G-1
			S A E	Assembly No. E-2	Rel. Code Pages 20-21			
Model ES60-5A								
301460								
-1	Navistar	Pull Type	2	46-518-22-1X	8	59-35-3	53-19-11-1X	59-15-7-2X
-2	Service	Push Type	2	46-518-22-1X	26	59-35-3	47-19-82-1X	59-15-3-2X
-3	Navistar	Push Type	2	46-518-23	—	59-35-5	47-19-77-1X	59-15-7-2X
-4	Navistar	Push Type	2	46-518-23	—	59-35-5	47-19-77-1X	59-15-7-2X
-5	Volvo-GM	Push Type	2	46-518-22-1X	—	59-35-3	47-19-82-1X	59-15-3-2X
-6	Vermeer Mfg.	Push Type	2	46-518-22-1X	26	59-35-3	47-19-82-1X	59-15-3-2X
-7	Service	Push Type	2	46-518-22-1X	26	59-35-3	47-19-78-1X	59-15-3-2X
-8	FWD Corp.	Push Type	2	46-518-22-1X	28	59-35-3	47-19-82-1X	59-15-3-2X
-9	Hendrickson	Push Type	2	46-518-22-1X	28	59-35-3	47-19-82-1X	59-15-10-2X
-10	Volvo-GM	Push Type	—	—	—	59-35-4	47-19-79-1X	59-15-3-2X
-11	Navistar	Pull Type	2	47-518-4-1X	—	59-35-2	53-19-11-1X	59-15-7-2X
-12	Navistar	Pull Type	2	47-518-4-1X	—	59-35-2	53-19-11-1X	59-15-7-2X
-13	Hendrickson	Pull Type	2	47-518-4-1X	68	59-35-2	53-19-11-1X	59-15-10-2X
-14	General use	Push Type	3	46-518-21-1X	36	59-35-3	47-19-82-1X	59-15-3-2X
-15	Wilson Mfg.	Pull Type	3	46-518-21-1X	8	59-35-3	53-19-11-1X	59-15-3-2X
-16	Blue Bird Body	Push Type	2	312830X	56	59-35-3	47-19-78-1X	59-15-9-2X
-17	General use	Push Type	2	46-518-22-1X	—	59-35-3	47-19-82-1X	59-15-3-2X
-18	Navistar	Pull Type	2	46-518-4-1X	—	59-35-9	53-19-11-1X	59-15-7-2X
-19	Cooper Mfg.	Push Type	3	46-518-21-1X	49	59-35-3	47-19-82-1X	59-15-3-2X
-20	Oshkosh Corp.	Push Type	2	46-518-22-1X	—	59-35-3	47-19-82-1X	59-15-3-2X
-21	FWD Corp.	Push Type	—	—	—	59-35-5	47-19-77-1X	59-15-3-2X
-22	Drivetrain	Push Type	—	—	—	59-35-3	47-19-82-1X	59-15-3-2X
-23	FWD Corp.	Push Type	2	46-518-22-1X	54	59-35-3	47-19-78-1X	59-15-3-2X
-24	Canadian Foremost	Push Type	3	46-518-21-1X	57	59-35-3	47-19-82-1X	59-15-3-2X
-25	Volvo-GM	Push Type	—	—	—	59-35-4	47-19-79-1X	59-15-3-2X
-26	Cooper Mfg.	Pull Type	2	46-518-22-1X	3	59-35-3	53-19-11-1X	59-15-3-2X
-27	Navistar	Pull Type	2	47-518-4-1X	—	59-35-9	53-19-11-1X	59-15-7-2X
-28	Drivetrain	Pull Type	2	47-518-4-1X	62	59-35-2	53-19-11-1X	59-15-3-2X
-29	Wich-Tex	Pull Type	2	46-518-22-1X	12	59-35-3	53-19-11-1X	59-15-3-2X
-30	Canadian Foremost	Push Type	3	46-518-21-1X	57	59-35-3	47-19-82-1X	59-15-3-2X
-31	Gradall	Pull Type	2	47-518-4-1X	67	59-35-2	53-19-11-1X	59-15-7-2X
-32	Wich-Tex	Pull Type	3	46-518-21-1X	12	59-35-3	53-19-11-1X	59-15-3-2X
-33*	Thomas Built Buses	Push Type	2	46-518-22-1X	55	59-35-3	47-19-78-1X	59-15-7-2X
-34	Spicer France	Push Type	—	—	—	59-35-3	47-19-78-1X	59-15-7-2X
-35	Volvo-GM	Push Type	2	46-518-13-1X	—	59-35-4	47-19-79-1X	59-15-3-2X
-36	Badger Equipment	Push Type	2	46-518-22-1X	53	59-35-3	47-19-78-1X	59-15-7-2X
-37	Badger Equipment	Push Type	2	46-518-22-1X	50	59-35-3	47-19-78-1X	59-15-7-2X
-38	Azcon Inc.	Pull Type	2	47-518-4-1X	62	59-35-2	53-19-11-1X	59-15-3-2X
-39	Ford	Push Type	—	—	—	59-35-6	47-19-73-1X	59-15-5-2X
-40	Ford	Push Type	—	—	—	59-35-6	49-19-73-1X	59-15-5-2X
-41	Ford	Push Type	—	—	—	59-35-6	47-19-73-1X	59-15-5-2X
-42	Ford	Push Type	2	47-518-5	—	59-35-7	47-19-74-1X	59-15-1-2X
-43	Ford	Push Type	2	47-518-5	—	59-35-7	47-19-74-1X	59-15-1-2X
-44	Ford	Push Type	2	47-518-5	—	59-35-7	47-19-74-1X	59-15-1-2X
-45	Ardco Inc.	Push Type	3	46-518-21-1X	19	59-35-3	47-19-82-1X	59-15-3-2X
-46	Ford	Pull Type	2	47-518-4-1X	—	59-35-2	53-19-11-1X	59-15-1-2X
-47	Ford	Pull Type	2	47-518-4-1X	—	59-35-2	53-19-11-1X	59-15-1-2X
-48	Ford	Pull Type	2	47-518-4-1X	—	59-35-2	53-19-11-1X	59-15-1-2X
-49	D.W.T.	Push Type	2	46-518-22-1X	26	59-35-3	47-19-82-1X	59-15-3-2X
-50	Volvo-GM	Push Type	2	47-518-10-1X	—	59-35-4	47-19-79-1X	59-15-3-2X
-51	D.W.T.	Push Type	2	47-518-5	—	59-35-7	47-19-74-1X	59-15-3-2X
-52	Vermeer Mfg.	Push Type	2	46-518-22-1X	26	59-35-3	47-19-82-1X	59-15-3-2X
-53	Davey-Kent	Pull Type	—	—	—	59-35-18	53-19-11-1X	59-15-3-2X
-54	D.W.T.	Push Type	3	46-518-21-1X	22	59-35-3	47-19-82-1X	59-15-3-2X

* Includes Neutral Safety Switch Kit 313262X - Shipped loose

PARTS LISTED IN THIS CATALOG MAY NO LONGER BE AVAILABLE, USE WITH TRANSMISSION SUPERSEDING LIST.

MODEL ES60-5

TABULATED BILLS OF MATERIAL

T210-ES60-5

Tab No.	Rear Bearing Cap Assembly Cap, Seal and Bushing H-1	SPEEDOMETER		End Yoke or Companion Flange B-22	SHIFTER		
		Drive Gear B-21	Driven Gear H-8		Housing Ass'y Pages 14-15	Lever & Dome Ass'y Page 19	Remote Control Pages 16-18
Model ES60-5A							
301460							
-1	53-19-1-4X	—	—	—	47-16-1-8X	47-16-3-1X	—
-2	53-19-12-4X	—	—	—	47-16-1-8X	47-16-3-1X	—
-3	53-19-1-4X	53-452-2	—	—	47-16-1-8X	—	—
-4	53-19-3-4X	53-452-2	—	—	47-16-1-8X	—	—
-5	53-19-12-4X	53-452-3	—	—	47-16-1-8X	—	—
-6	53-19-12-4X	—	—	—	47-16-1-8X	—	47-16-8-2X
-7	53-19-12-4X	—	—	—	47-16-1-8X	47-16-3-1X	—
-8	53-19-12-4X	—	—	—	47-16-1-8X	—	—
-9	53-19-12-4X	53-452-3	62-453-4	5-4-6321	47-16-1-11X	—	47-16-8-2X
-10	53-19-12-4X	—	—	—	—	—	—
-11	53-19-1-4X	53-452-2	—	—	47-16-1-8X	—	—
-12	53-19-3-4X	53-452-2	—	—	47-16-1-8X	—	—
-13	53-19-12-4X	53-452-3	62-453-4	5-4-6321	47-16-1-11X	—	47-16-8-2X
-14	53-19-12-4X	—	—	—	47-16-1-8X	47-16-3-1X	—
-15	53-19-12-4X	—	—	—	47-16-1-8X	47-16-3-1X	—
-16	53-19-12-4X	53-452-3	62-453-4	—	47-16-1-11X	—	—
-17	53-19-12-4X	53-452-3	62-453-4	—	47-16-1-8X	—	—
-18	53-19-1-4X	53-452-3	—	—	47-16-1-8X	—	—
-19	53-19-12-4X	—	—	—	47-16-1-16X	—	—
-20	53-19-12-4X	53-452-3	62-453-4	—	47-16-1-8X	47-16-3-25X	—
-21	53-19-12-4X	—	—	—	47-16-1-8X	—	—
-22	53-19-12-4X	—	—	—	47-16-1-8X	—	—
-23	53-19-12-4X	—	—	—	47-16-1-8X	—	—
-24	53-19-12-4X	—	—	53-106-2	47-16-1-8X	—	47-16-8-2X
-25	53-19-12-4X	—	—	—	47-16-1-10X	—	—
-26	53-19-12-4X	—	—	—	47-16-1-8X	—	47-16-8-2X
-27	53-19-3-4X	53-452-2	—	—	47-16-1-8X	—	—
-28	53-19-12-4X	—	—	—	47-16-1-8X	—	—
-29	53-19-12-4X	—	—	—	47-16-1-8X	47-16-3-1X	—
-30	53-19-12-4X	—	—	—	47-16-1-8X	—	—
-31	53-19-12-4X	—	—	5-4-6321	47-16-1-11X	—	47-16-8-2X
-32	53-19-12-4X	—	—	—	47-16-1-8X	47-16-3-1X	—
-33	53-19-12-4X	—	—	5-4-6321	47-16-1-11X	—	47-16-9-2X
-34	53-19-12-4X	53-452-4	53-453-2	4-4-4491	47-16-1-11X	—	—
-35	53-19-12-4X	53-452-3	—	—	47-16-1-8X	—	—
-36	53-19-12-4X	—	—	5-4-6321	47-16-1-11X	—	47-16-8-2X
-37	53-19-12-4X	—	—	5-4-6321	47-16-1-11X	—	47-16-8-2X
-38	53-19-12-4X	—	—	53-106-2	47-16-1-8X	47-16-3-1X	—
-39	53-19-13-2X	—	—	—	47-16-1-8X	—	—
-40	53-19-15-2X	—	—	—	47-16-1-8X	—	—
-41	53-19-17-2X	—	—	—	47-16-1-8X	—	—
-42	53-19-13-2X	—	—	—	47-16-1-8X	—	—
-43	53-19-15-2X	—	—	—	47-16-1-8X	—	—
-44	53-19-17-2X	—	—	—	47-16-1-8X	—	—
-45	53-19-12-4X	—	—	53-106-1	47-16-1-8X	47-16-5-38X	—
-46	53-19-13-2X	—	—	—	47-16-1-8X	—	—
-47	53-19-15-2X	—	—	—	47-16-1-8X	—	—
-48	53-19-17-2X	—	—	—	47-16-1-8X	—	—
-49	53-19-12-4X	53-452-3	62-453-4	5-4-6321	47-16-1-8X	47-16-3-1X	—
-50	53-19-7-4X	53-452-3	—	—	47-16-1-8X	—	—
-51	53-19-12-4X	53-452-3	62-453-4	5-4-6321	47-16-1-8X	47-16-3-1X	—
-52	53-19-12-4X	—	—	—	47-16-1-16X	—	—
-53	53-19-12-4X	—	—	53-106-2	47-16-1-16X	—	—
-54	53-19-12-4X	53-452-3	62-453-4	53-106-2	47-16-1-8X	47-16-3-25X	—

MODEL ES60-5

T210-ES60-5

TABULATED BILLS OF MATERIAL

Tab No.	Used By	For Use With Clutch 13" or 14" Single or 2PL	CLUTCH HOUSING			Main Drive Gear A-1	Drive Gear Bearing Cap F-2	Main Case Assembly G-1
			S A E	Assembly No. E-2	Rel. Code Pages 20-21			
Model ES60-5A								
301460 (Cont'd)								
-55	Wilson Mfg.	Pull Type	2	46-518-22-1X	8	59-35-3	53-19-11-1X	59-15-3-2X
-56	Australia	Push Type	2	46-518-22-1X	51	59-35-3	49-19-82-1X	59-15-3-2X
-57	Volvo-GM	Push Type	2	47-518-10-1X	—	59-35-4	47-19-79-1X	59-15-3-2X
-58	Davey-Kent	Pull Type	—	—	—	59-35-18	53-19-11-1X	59-15-3-2X
-59	Capitol Trencher	Pull Type	—	—	—	59-35-2	53-19-11-1X	59-15-5-2X
-60	Spicer France	Push Type	—	—	—	59-35-3	47-19-78-1X	59-15-7-2X
-61	Stockdale Mine	Pull Type	2	313216	—	59-35-18	53-19-11-1X	59-15-3-2X
-62	Salem Tool	Pull Type	2	47-518-4-1X	63	59-35-9	53-19-11-1X	53-15-3-2X
-63	Volvo-GM	Push Type	2	312256X	—	59-35-10	47-19-80-1X	59-15-3-2X
-64	Volvo-GM	Pull Type	2	47-518-4-1X	2	59-35-2	53-19-11-1X	59-15-3-2X
-65	Ford	Push Type	—	—	—	59-35-6	47-19-73-1X	59-15-5-2X
-66	Ford	Push Type	—	—	—	59-35-6	47-19-73-1X	59-15-5-2X
-67	Ford	Push Type	2	47-518-5	—	59-35-7	47-19-74-1X	59-15-1-2X
-68	Ford	Push Type	2	47-518-5	—	59-35-7	47-19-74-1X	59-15-1-2X
-69	Ford	Pull Type	2	47-518-4-1X	—	59-35-2	53-19-11-1X	59-15-1-1X
-70	Vermeer Mfg.	Push Type	2	47-518-22-1X	26	59-35-3	47-19-82-1X	59-15-3-2X
-71	Walker Neer Machine	Pull Type	2	46-518-22-1X	—	59-35-3	53-19-11-1X	59-15-3-2X
-72	Spicer France	Push Type	—	—	—	59-35-3	47-19-78-1X	59-15-7-2X
-73	Spicer France	Push Type	—	—	—	59-35-3	47-19-78-1X	59-15-7-2X
-74	Thomas Built Buses	Pull Type	2	47-518-4-1X	—	59-35-2	53-19-11-1X	59-15-7-2X
-75	Gradall Co.	Push Type	2	46-518-22-1X	26	59-35-3	47-19-82-1X	59-15-7-2X
-76	Volvo-GM	Push Type	2	312256X	—	59-35-10	47-19-80-1X	59-15-3-2X
Model ES60-5C								
301461								
-1	Navistar	Pull Type	2	46-518-22-1X	8	59-35-3	53-19-11-1X	59-15-7-2X
-2	Volvo-GM	Push Type	2	46-518-22-1X	—	59-35-3	47-19-82-1X	59-15-3-2X
-3	Blue Bird	Push Type	2	312830X	56	59-35-3	47-19-78-1X	59-15-9-2X
-4	Gradall Co.	Push Type	2	46-518-22-1X	34	59-35-3	47-19-82-1X	59-15-7-2X
-5	Volvo-GM	Push Type	2	46-518-22-1X	—	59-35-3	47-19-82-1X	59-15-3-2X
-6	Gradall Co.	Push Type	3	46-518-21-1X	24	59-35-3	47-19-82-1X	59-15-7-2X
-7	Volvo-GM	Push Type	—	—	—	59-35-3	47-19-82-1X	59-15-3-2X
-8	Volvo-GM	Push Type	—	—	—	59-35-3	47-19-82-1X	59-15-3-2X
-9	Navistar	Push Type	2	46-518-23	—	59-35-3	47-19-77-1X	59-15-7-2X
-10	Volvo-GM	Push Type	2	46-518-22-1X	—	59-35-3	47-19-82-1X	59-15-3-2X
-11	Navistar	Pull Type	2	47-518-4-1X	—	59-35-2	53-19-11-1X	59-15-7-2X
-12	Drivetrain	Push Type	—	—	—	59-35-3	47-19-82-1X	59-15-3-2X
-13	Western Star Truck	Pull Type	2	47-518-4-1X	—	59-35-2	53-19-11-1X	59-15-3-2X
-14	Volvo-GM	Push Type	—	—	—	59-35-3	47-19-82-1X	59-15-3-2X
-15	Navistar	Pull Type	2	47-518-4-1X	—	59-35-2	53-19-11-1X	59-15-7-2X
-16	Universal Go-Tract	Push Type	2	46-518-22-1X	34	59-35-3	47-19-82-1X	59-15-3-2X
-17	Drivetrain	Push Type	2	46-518-22-1X	—	59-35-3	47-19-82-1X	59-15-3-2X
-18	Volvo-GM	Push Type	2	46-518-13-1X	—	59-35-4	47-19-79-1X	59-15-3-2X
-19	Volvo-GM	Push Type	2	46-518-13-1X	—	59-35-4	47-19-79-1X	59-15-3-2X
-20	Volvo-GM	Push Type	2	46-518-13-1X	—	59-35-4	47-19-79-1X	59-15-3-2X
-21	Service	Push Type	2	46-518-22-1X	34	59-35-4	47-19-82-1X	59-15-7-2X
-22	Volvo-GM	Push Type	2	312256X	—	59-35-10	47-19-80-1X	59-15-3-2X
-23	Navistar	Pull Type	2	47-518-4-1X	—	59-35-9	53-19-11-1X	59-15-7-2X
-24	Gradall Co.	Push Type	2	46-518-22-1X	34	59-35-3	47-19-82-1X	59-15-7-2X
-25	Shear Truck	Push Type	2	46-518-22-1X	33	59-35-3	47-19-82-1X	59-15-9-2X
-26	FMC Corp.	Push Type	2	46-518-22-1X	20	59-35-3	47-19-82-1X	59-15-3-2X
-27	Volvo-GM	Push Type	2	47-518-10-1X	—	59-35-4	47-19-79-1X	59-15-3-2X
-28	Volvo-GM	Push Type	2	47-518-10-1X	—	59-35-4	47-19-79-1X	59-15-3-2X
-29	Volvo-GM	Push Type	2	47-518-10-1X	—	59-35-4	47-19-79-1X	59-15-3-2X
-30	Volvo-GM	Push Type	2	312256X	—	59-35-10	47-19-80-1X	59-15-3-2X
-31	Navistar	Pull Type	2	47-518-4-1X	—	59-35-9	53-19-11-1X	59-15-7-2X
-32	Ford	Push Type	2	47-518-5	—	59-35-7	47-19-74-1X	59-15-1-2X

* Includes Neutral Safety Switch Kit 313262X - Shipped loose

PARTS LISTED IN THIS CATALOG MAY NO LONGER BE AVAILABLE, USE WITH TRANSMISSION SUPERSEDING LIST.

MODEL ES60-5

TABULATED BILLS OF MATERIAL

T210-ES60-5

Tab No.	Rear Bearing Cap Assembly Cap, Seal and Bushing H-1	SPEEDOMETER		End Yoke or Companion Flange B-22	SHIFTER		
		Drive Gear B-21	Driven Gear H-8		Housing Ass'y Pages 14-15	Lever & Dome Ass'y Page 19	Remote Control Pages 16-18
Model ES60-5A							
301460 (Cont'd)							
-55	53-19-12-4X	—	—	—	47-16-1-8X	47-16-3-1X	—
-56	53-19-12-4X	53-452-3	62-453-4	—	47-16-1-8X	—	47-16-8-2X
-57	53-19-12-4X	53-452-3	—	—	47-16-1-8X	—	—
-58	53-19-12-4X	—	—	53-106-2	47-16-1-16X	47-16-3-1X	—
-59	53-19-13-2X	—	—	—	47-16-1-8X	—	—
-60	53-19-7-4X	53-452-4	53-453-2	—	47-16-1-11X	—	—
-61	53-19-12-4X	—	—	3-4-8781	47-16-1-16X	47-16-3-1X	—
-62	53-19-12-4X	—	—	—	47-16-1-8X	—	—
-63	53-19-12-4X	53-452-3	—	—	47-16-1-8X	—	—
-64	53-19-12-4X	53-452-3	—	—	47-16-1-8X	—	—
-65	53-19-22-1X	53-452-6	—	4-4-4611-2	47-16-1-8X	—	—
-66	53-19-22-1X	53-452-6	—	5-4-6481-1	47-16-1-8X	—	—
-67	53-19-22-1X	53-452-6	—	4-4-4611-2	47-16-1-8X	—	—
-68	53-19-22-1X	53-452-6	—	5-4-6481-1	47-16-1-8X	—	—
-69	53-19-22-1X	53-452-6	—	5-4-6481-1	47-16-1-8X	—	—
-70	53-19-12-4X	—	—	—	47-16-1-18X	—	—
-71	53-19-12-4X	—	—	53-106-1	47-16-1-8X	47-16-3-1X	—
-72	53-19-12-4X	53-452-4	53-453-2	4-4-4491	47-16-1-11X	—	—
-73	53-19-12-4X	53-452-4	53-453-2	4-4-4491	47-16-1-8X	47-16-5-43X	—
-74	53-19-12-4X	—	—	—	47-16-1-13X	—	—
-75	53-19-12-4X	—	—	5-4-6321	47-16-1-11X	—	—
-76	53-19-7-4X	53-452-3	—	—	47-16-1-8X	—	—
Model ES60-5C							
301461							
-1	53-19-1-4X	—	—	—	47-16-1-8X	47-16-3-1X	—
-2	53-19-12-4X	53-452-3	—	—	47-16-1-8X	—	—
-3	53-19-12-4X	53-452-3	62-453-4	—	47-16-1-11X	—	—
-4	53-19-12-4X	—	—	5-4-6321	47-16-1-11X	—	47-16-8-2X
-5	53-19-7-4X	53-452-3	—	—	47-16-1-8X	—	—
-6	53-19-12-4X	—	—	5-4-6321	47-16-1-11X	—	47-16-8-2X
-7	53-19-12-4X	—	—	—	—	—	—
-8	53-19-7-4X	—	—	—	—	—	—
-9	53-19-1-4X	53-452-2	—	—	47-16-1-10X	—	—
-10	53-19-12-4X	53-452-3	—	53-106-2	47-16-1-8X	—	—
-11	53-19-3-4X	53-452-2	—	—	47-16-1-8X	—	—
-12	53-19-12-4X	—	—	—	47-16-1-8X	—	—
-13	53-19-12-4X	—	—	—	47-16-1-8X	—	—
-14	53-19-12-4X	—	—	—	47-16-1-10X	—	—
-15	53-19-1-4X	—	—	—	47-16-1-8X	—	—
-16	53-19-12-4X	—	—	53-106-2	47-16-1-11X	—	—
-17	53-19-12-4X	—	—	53-106-2	47-16-1-8X	47-16-3-1X	—
-18	53-19-7-4X	53-452-3	—	—	47-16-1-8X	—	—
-19	53-19-12-4X	53-452-3	—	—	47-16-1-8X	—	—
-20	53-19-12-4X	53-452-3	—	5-4-6321	47-16-1-8X	—	—
-21	53-19-12-4X	53-452-3	62-453-4	5-4-6321	47-16-1-11X	47-16-3-1X	—
-22	53-19-12-4X	53-452-3	—	—	47-16-1-8X	—	—
-23	53-19-3-4X	53-452-2	—	—	47-16-1-8X	—	—
-24	53-19-12-4X	—	—	5-4-6321	47-16-1-11X	—	—
-25	53-19-12-4X	53-452-3	62-453-4	53-106-2	47-16-1-8X	47-16-5-21X	—
-26	53-19-12-4X	—	—	—	47-16-1-8X	47-16-3-1X	—
-27	53-19-7-4X	53-452-3	—	—	47-16-1-8X	—	—
-28	53-19-12-4X	53-452-3	—	—	47-16-1-8X	—	—
-29	53-19-12-4X	53-452-3	—	—	47-16-1-8X	—	—
-30	53-19-7-4X	53-452-3	—	—	47-16-1-8X	—	—
-31	53-19-1-4X	53-452-2	—	—	47-16-1-8X	—	—
-32	53-19-13-2X	—	—	—	47-16-1-8X	—	—

MODEL ES60-5

T210-ES60-5

TABULATED BILLS OF MATERIAL

Tab No.	Used By	For Use With Clutch 13" or 14" Single or 2PL	CLUTCH HOUSING			Main Drive Gear A-1	Drive Gear Bearing Cap F-2	Main Case Assembly G-1
			S A E	Assembly No. E-2	Rel. Code Pages 20-21			
Model ES60-5C								
301461 (Cont'd)								
-33	Ford	Push Type	2	47-518-5	—	59-35-7	47-19-74-1X	59-15-1-2X
-34	Ford	Push Type	2	47-518-5	—	59-35-7	47-19-74-1X	59-15-1-2X
-35	Ford	Push Type	—	—	—	59-35-6	47-19-73-1X	59-15-5-2X
-36	Ford	Push Type	—	—	—	59-35-6	47-19-73-1X	59-15-5-2X
-37	Ford	Push Type	—	—	—	59-35-6	47-19-73-1X	59-15-5-2X
-38	Service	Pull Type	2	47-518-4-1X	70	59-35-2	53-19-11-1X	59-15-3-2X
-39	Ford	Pull Type	2	47-518-4-1X	—	59-35-2	53-19-11-1X	59-15-1-2X
-40	Service	Pull Type	2	46-518-22-1X	8	59-35-3	53-19-11-1X	59-15-3-2X
-41	Ford	Pull Type	2	47-518-4-1X	—	59-35-2	53-19-11-1X	59-15-1-1X
-42	Ford	Pull Type	2	47-518-4-1X	—	59-35-2	53-19-11-1X	59-15-1-1X
-43	Universal Go-Tract	Push Type	3	46-518-21-1X	34	59-35-3	47-19-82-1X	59-15-3-2X
-44	Universal Go-Tract	Push Type	—	—	34	59-35-3	47-19-82-1X	59-15-3-2X
-45	Service	Pull Type	2	46-518-22-1X	—	59-35-3	53-19-11-1X	59-15-3-2X
-46	Universal Go-Tract	Push Type	3	46-518-21-1X	34	59-35-3	47-19-82-1X	59-15-3-2X
-47	Thomas Built Buses	Pull Type	2	47-518-4-1X	75	59-35-2	53-19-11-1X	59-15-7-2X
-48	Volvo-GM	Pull Type	2	47-518-4-1X	—	59-35-2	53-19-11-1X	59-15-3-2X
-49	Tree Farmer	Push Type	3	46-518-21-1X	—	59-35-3	47-19-82-1X	59-15-3-2X
Model ES60-5D								
301462								
-1	Navistar	Pull Type	2	46-518-22-1X	8	59-35-3	53-19-11-1X	59-15-7-2X
-2	Navistar	Push Type	2	46-518-23	—	59-35-5	47-19-77-1X	59-15-7-2X
-3	Navistar	Pull Type	2	47-518-4-1X	—	59-35-9	53-19-11-1X	59-15-7-2X
-4	Navistar	Pull Type	2	47-518-4-1X	—	59-35-9	53-19-11-1X	59-15-7-2X
-5	Volvo-GM	Push Type	2	47-518-10-1X	—	59-35-4	47-19-79-1X	59-15-3-2X
-6	Volvo-GM	Push Type	2	47-518-10-1X	—	59-35-4	47-19-79-1X	59-15-3-2X
-7	Volvo-GM	Push Type	2	47-518-13-1X	—	59-35-4	47-19-79-1X	59-15-3-2X
-8	Volvo-GM	Push Type	2	47-518-13-1X	—	59-35-4	47-19-79-1X	59-15-3-2X
-9	Volvo-GM	Push Type	2	312256X	—	59-35-10	47-19-80-1X	59-15-3-2X
-10	Volvo-GM	Push Type	2	312256X	—	59-35-10	47-19-80-1X	59-15-3-2X
-11	Ford	Push Type	2	47-518-5	—	59-35-7	47-19-74-1X	59-15-1-1X
-12	Ford	Push Type	2	47-518-5	—	59-35-7	47-19-74-1X	59-15-1-1X
-13	Ford	Push Type	2	47-518-5	—	59-35-7	47-19-74-1X	59-15-1-2X
-14	Ford	Pull Type	2	47-518-4-1X	—	59-35-2	53-19-11-1X	59-15-1-2X
-15	Ford	Pull Type	2	47-518-4-1X	—	59-35-2	53-19-11-1X	59-15-1-2X
-16	Ford	Pull Type	2	47-518-4-1X	—	59-35-2	53-19-11-1X	59-15-1-2X
-17	Ford	Push Type	—	—	—	59-35-6	47-19-73-1X	59-15-5-2X
-18	Ford	Push Type	—	—	—	59-35-6	47-19-73-1X	59-15-5-2X
-19	Navistar	Pull Type	2	46-518-22-1X	8	59-35-3	53-19-11-1X	59-15-3-2X
-20	Ford	Push Type	—	—	—	59-35-6	47-19-73-1X	59-15-5-2X
-21	Ford	Pull Type	2	47-518-4-1X	—	59-35-2	53-19-11-1X	59-15-3-2X
-22	Volvo-GM	Pull Type	2	47-518-4-1X	—	59-35-2	53-19-11-1X	59-15-3-2X
-23	Diesel Equipment	Push Type	2	46-518-22-1X	51	59-35-3	47-19-82-1X	59-15-3-2X
-24	Navistar	Push Type	2	46-518-23	—	59-35-5	47-19-77-1X	59-15-7-2X
-25	Badger Equipment	Pull Type	2	47-518-4-1X	67	59-35-9	53-19-11-1X	59-15-3-2X
-26	D.W.T.	Pull Type	2	47-518-4-1X	70	59-35-2	53-19-11-1X	59-15-3-2X
-27	Navistar	Pull Type	2	47-518-4-1X	—	59-35-9	53-19-11-1X	59-15-7-2X
-28	Navistar	Pull Type	2	47-518-4-1X	—	59-35-9	53-19-11-1X	59-15-7-2X
-29	Navistar	Pull Type	2	47-518-4-1X	—	59-35-9	53-19-11-1X	59-15-7-2X
-30	Navistar	Pull Type	2	47-518-4-1X	—	59-35-9	53-19-11-1X	59-15-7-2X
Model ES60-5E								
301463								
-1	Volvo-GM	Push Type	2	46-518-22-1X	—	59-35-1	47-19-82-1X	59-15-3-2X
-2	Navistar	Push Type	2	46-518-23	—	59-35-12	47-19-77-1X	59-15-7-2X
-3	Blue Bird Body	Push Type	2	312830X	56	59-35-1	47-19-78-1X	59-15-9-2X
-4	Volvo-GM	Push Type	2	312256X	—	59-35-15	47-19-80-1X	59-15-3-2X

PARTS LISTED IN THIS CATALOG MAY NO LONGER BE AVAILABLE, USE WITH TRANSMISSION SUPERSEDING LIST.

MODEL ES60-5

TABULATED BILLS OF MATERIAL

T210-ES60-5

Tab No.	Rear Bearing Cap Assembly Cap, Seal and Bushing H-1	SPEEDOMETER		End Yoke or Companion Flange B-22	SHIFTER		
		Drive Gear B-21	Driven Gear H-8		Housing Ass'y Pages 14-15	Lever & Dome Ass'y Page 19	Remote Control Pages 16-18
Model ES60-5C							
301461(Cont'd)							
-33	53-19-15-2X	—	—	—	47-16-1-8X	—	—
-34	53-19-17-2X	—	—	—	47-16-1-8X	—	—
-35	53-19-13-2X	—	—	—	47-16-1-8X	—	—
-36	53-19-15-2X	—	—	—	47-16-1-8X	—	—
-37	53-19-17-2X	—	—	—	47-16-1-8X	—	—
-38	53-19-12-4X	53-452-3	62-453-4	53-106-2	47-16-1-8X	47-16-3-1X	—
-39	53-19-13-2X	—	—	—	47-16-1-8X	—	—
-40	53-19-12-4X	—	—	—	47-16-1-8X	47-16-3-1X	—
-41	53-19-17-2X	—	—	—	47-16-1-8X	—	—
-42	53-19-15-2X	—	—	—	47-16-1-8X	—	—
-43	53-19-12-4X	—	—	53-106-2	47-16-1-11X	—	—
-44	53-19-12-4X	—	—	53-106-2	47-16-1-11X	—	—
-45	53-19-12-4X	—	—	—	47-16-1-8X	—	—
-46	53-19-12-4X	—	—	53-106-2	47-16-1-11X	—	—
-47	53-19-12-4X	—	—	—	47-16-1-13X	—	—
-48	53-19-12-4X	53-452-3	—	—	47-16-1-8X	—	—
-49	53-19-12-4X	—	—	4-4-4491	47-16-1-17X	—	—
Model ES60-5D							
301462							
-1	53-19-1-4X	—	—	—	47-16-1-8X	47-16-3-1X	—
-2	53-19-3-4X	53-452-2	—	—	47-16-1-8X	—	—
-3	53-19-3-4X	53-452-2	—	—	47-16-1-8X	—	—
-4	53-19-1-4X	53-452-2	—	—	47-16-1-8X	—	—
-5	53-19-7-4X	53-452-3	—	—	47-16-1-8X	—	—
-6	53-19-12-4X	53-452-3	—	—	47-16-1-8X	—	—
-7	53-19-12-4X	53-452-3	—	—	47-16-1-8X	—	—
-8	53-19-7-4X	53-452-3	—	—	47-16-1-8X	—	—
-9	53-19-12-4X	53-452-3	—	—	47-16-1-8X	—	—
-10	53-19-7-4X	53-452-3	—	—	47-16-1-8X	—	—
-11	53-19-13-2X	—	—	—	47-16-1-8X	—	—
-12	53-19-15-2X	—	—	—	47-16-1-8X	—	—
-13	53-19-17-2X	—	—	—	47-16-1-8X	—	—
-14	53-19-13-2X	—	—	—	47-16-1-8X	—	—
-15	53-19-17-2X	—	—	—	47-16-1-8X	—	—
-16	53-19-15-2X	—	—	—	47-16-1-8X	—	—
-17	53-19-15-2X	—	—	—	47-16-1-8X	—	—
-18	53-19-17-2X	—	—	—	47-16-1-8X	—	—
-19	53-19-12-4X	—	—	—	47-16-1-8X	47-1-6-3-1X	—
-20	53-19-13-2X	—	—	—	47-16-1-8X	—	—
-21	53-19-12-2X	53-452-3	—	—	47-16-1-8X	—	—
-22	53-19-7-2X	53-452-3	—	—	47-16-1-8X	—	—
-23	53-19-12-4X	—	—	53-106-2	47-16-1-8X	47-16-3-1X	—
-24	53-19-1-4X	53-452-2	—	—	47-16-1-8X	—	—
-25	53-19-12-4X	—	—	5-4-6321	47-16-1-8X	—	47-16-8-2X
-26	53-19-12-4X	53-452-3	62-453-4	—	47-16-1-8X	47-16-3-25X	—
-27	53-19-3-4X	53-452-2	—	—	47-16-1-8X	—	—
-28	53-19-1-4X	53-452-2	—	—	47-16-1-8X	—	—
-29	53-19-26-2X	53-452-5	—	—	47-16-1-8X	—	—
-30	53-19-24-2X	53-452-5	—	—	47-16-1-8X	—	—
Model ES60-5E							
301463							
-1	53-19-12-4X	53-452-3	—	—	47-16-1-8X	—	—
-2	53-19-3-4X	53-452-2	—	—	47-16-1-8X	—	—
-3	53-19-12-4X	53-452-3	62-453-4	—	47-16-1-11X	—	—
-4	53-19-12-4X	53-452-3	—	—	47-16-1-8X	—	—

MODEL ES60-5

T210-ES60-5

TABULATED BILLS OF MATERIAL

Tab No.	Used By	For Use With Clutch 13" or 14" Single or 2PL	CLUTCH HOUSING			Main Drive Gear A-1	Drive Gear Bearing Cap F-2	Main Case Assembly G-1
			S A E	Assembly No. E-2	Rel. Code Pages 20-21			
Model ES60-5E								
301463 (Cont'd)								
-5	Volvo-GM	Push Type	2	46-518-22-1X	—	59-35-1	47-19-82-1X	59-15-3-2X
-6	Volvo-GM	Push Type	—	—	—	59-35-15	47-19-80-1X	59-15-3-2X
-7	Volvo-GM	Push Type	—	—	—	59-35-1	47-19-82-1X	59-15-3-2X
-8	Navistar	Pull Type	2	47-518-4-1X	—	59-35-14	53-19-11-1X	59-15-7-2X
-9	Navistar	Pull Type	2	47-518-4-1X	—	59-35-14	53-19-11-1X	59-15-7-2X
-10	Volvo-GM	Push Type	2	46-518-22-1X	—	59-35-1	47-19-82-1X	59-15-9-2X
-11	Volvo-GM	Push Type	2	46-518-22-1X	—	59-35-1	47-19-82-1X	59-15-9-2X
-12	Volvo-GM	Push Type	2	312256X	—	59-35-15	47-19-80-1X	59-15-9-2X
-13	Navistar	Pull Type	2	47-518-4-1X	—	59-35-16	53-19-11-1X	59-15-7-2X
-14	Volvo-GM	Push Type	—	—	—	59-35-1	47-19-82-1X	59-15-3-2X
-15	Canadian Foremost	Push Type	3	46-518-21-1X	57	59-35-1	47-19-82-1X	59-15-3-2X
-16	Service	Push Type	2	46-518-22-1X	—	59-35-1	47-19-82-1X	59-15-3-2X
-17	Drivetrain	Pull Type	—	—	—	59-35-1	53-19-11-1X	59-15-3-2X
-18	Drivetrain	Push Type	—	—	—	59-35-1	47-19-82-1X	59-15-3-2X
-19	Volvo-GM	Push Type	—	—	—	59-35-15	47-19-80-1X	59-15-3-2X
-20	Volvo-GM	Push Type	—	—	—	59-35-1	47-19-82-1X	59-15-3-2X
-21	Drivetrain	Pull Type	2	47-518-4-1X	62	59-35-14	53-19-11-1X	59-15-3-2X
-22	Volvo-GM	Push Type	2	312256X	—	59-35-15	47-19-80-1X	59-15-3-2X
-23	Navistar	Pull Type	2	47-518-4-1X	—	59-35-16	53-19-11-1X	59-15-7-2X
-24	Volvo-GM	Push Type	2	47-518-13-1X	—	59-35-13	47-19-79-1X	59-15-3-2X
-25	T.S.P.	Pull Type	2	46-518-22-1X	—	59-35-1	53-19-11-1X	59-15-3-2X
-26	Volvo-GM	Push Type	2	46-518-13-1X	—	59-35-13	47-19-79-1X	59-15-3-2X
-27	Volvo-GM	Push Type	2	46-518-13-1X	—	59-35-13	47-19-79-1X	59-15-3-2X
-28	Volvo-GM	Push Type	2	46-518-13-1X	—	59-35-13	47-19-79-1X	59-15-9-2X
-29	Volvo-GM	Push Type	2	46-518-13-1X	—	59-35-13	47-19-79-1X	59-15-9-2X
-30	Spicer France	Push Type	—	—	—	59-35-1	47-19-78-1X	59-15-7-2X
-31	Volvo-GM	Push Type	2	47-518-10-1X	—	59-35-13	47-19-79-1X	59-15-3-2X
-32	Volvo-GM	Push Type	2	47-518-10-1X	—	59-35-13	47-19-79-1X	59-15-3-2X
-33	Transquipment Incorp.	Push Type	3	46-518-21-1X	22	59-35-1	47-19-82-1X	59-15-3-2X
-34	Vermeer Mfg.	Push Type	2	46-518-22-1X	26	59-35-1	47-19-82-1X	59-15-3-2X
-35	Ford	Pull Type	—	—	—	59-35-11	47-19-73-1X	59-15-5-2X
-36	Ford	Push Type	—	—	—	59-35-11	47-19-73-1X	59-15-5-2X
-37	Ford	Push Type	—	—	—	59-35-11	47-19-73-1X	59-15-5-2X
-38	Ford	Push Type	2	47-518-5	—	59-35-17	47-19-74-1X	59-15-1-2X
-39	Ford	Push Type	2	47-518-5	—	59-35-17	47-19-74-1X	59-15-1-2X
-40	Ford	Push Type	2	47-518-5	—	59-35-17	47-19-74-1X	59-15-1-2X
-41	Vermeer Mfg.	Push Type	2	46-518-22-1X	26	59-35-1	47-19-82-1X	59-15-12-4X
-42	Ford	Pull Type	2	47-518-4-1X	—	59-35-14	53-19-11-1X	59-15-1-2X
-43	Ford	Pull Type	2	47-518-4-1X	—	59-35-14	53-19-11-1X	59-15-1-2X
-44	Ford	Pull Type	2	47-518-4-1X	—	59-35-14	53-19-11-1X	59-15-1-2X
-45	Service	Pull Type	2	46-518-22-1X	8	59-35-1	53-19-11-1X	59-15-3-2X
-46	Volvo-GM	Pull Type	2	47-518-4-1X	—	59-35-14	53-19-11-1X	59-15-3-2X
-47	Volvo-GM	Pull Type	2	47-518-4-1X	—	59-35-14	53-19-11-1X	59-15-3-2X
-48	Rolligon Corp.	Pull Type	2	47-518-4-1X	62	59-35-14	53-19-11-1X	59-15-7-2X
-49	Spicer France	Push Type	—	—	—	59-35-1	47-19-78-1X	59-15-7-2X
-50	T.S.P.	Push Type	2	312830X	56	59-35-1	47-19-78-1X	59-15-9-2X
-51	Ford	Push Type	—	—	—	59-35-11	47-19-73-1X	59-15-5-2X
-52	Ford	Push Type	—	—	—	59-35-11	47-19-73-1X	59-15-5-2X
-53	Ford	Push Type	2	47-518-5	—	59-35-17	47-19-74-1X	59-15-1-2X
-54	Ford	Push Type	2	47-518-5	—	59-35-17	47-19-74-1X	59-15-1-2X
-55	Ford	Pull Type	2	47-518-4-1X	—	59-35-14	53-19-11-1X	59-15-1-2X
-56	Spicer France	Push Type	—	—	—	59-35-1	47-19-78-1X	59-15-7-2X
-57	Spicer France	Push Type	—	—	—	59-35-1	47-19-78-1X	59-15-7-2X

PARTS LISTED IN THIS CATALOG MAY NO LONGER BE AVAILABLE, USE WITH TRANSMISSION SUPERSEDING LIST.

MODEL ES60-5

TABULATED BILLS OF MATERIAL

T210-ES60-5

Tab No.	Rear Bearing Cap Assembly Cap, Seal and Bushing H-1	SPEEDOMETER		End Yoke or Companion Flange B-22	SHIFTER		
		Drive Gear B-21	Driven Gear H-8		Housing Ass'y Pages 14-15	Lever & Dome Ass'y Page 19	Remote Control Pages 16-18
Model ES60-5E							
301463 (Cont'd)							
-5	53-19-7-4X	53-452-3	—	—	47-16-1-8X	—	—
-6	53-19-12-4X	—	—	—	—	—	—
-7	53-19-12-4X	—	—	—	—	—	—
-8	53-19-1-4X	53-452-2	—	—	47-16-1-8X	—	—
-9	53-19-3-4X	53-452-2	—	—	47-16-1-8X	—	—
-10	53-19-7-4X	53-452-3	—	—	47-16-1-8X	—	—
-11	53-19-12-4X	53-452-3	—	—	47-16-1-8X	—	—
-12	53-19-12-4X	53-452-3	—	—	47-16-1-8X	—	—
-13	53-19-1-4X	53-452-2	—	—	47-16-1-8X	—	—
-14	53-19-7-4X	—	—	—	—	—	—
-15	53-19-12-4X	—	—	53-106-2	47-16-1-8X	—	—
-16	53-19-12-4X	—	—	—	47-16-1-8X	—	—
-17	53-19-12-4X	—	—	—	47-16-1-8X	47-16-3-1X	—
-18	53-19-12-4X	—	—	—	47-16-1-8X	—	—
-19	53-19-12-4X	—	—	—	47-16-1-10X	—	—
-20	53-19-12-4X	—	—	—	47-16-1-10X	—	—
-21	53-19-12-4X	—	—	—	47-16-1-8X	—	—
-22	53-19-7-4X	53-452-3	—	—	47-16-1-8X	—	—
-23	53-19-3-4X	53-452-2	—	—	47-16-1-8X	—	—
-24	53-19-12-4X	53-452-3	—	—	47-16-1-10X	—	—
-25	53-19-12-4X	53-452-3	62-453-4	53-106-2	47-16-1-12X	47-16-3-25X	—
-26	53-19-7-4X	53-452-3	—	—	47-16-1-8X	—	—
-27	53-19-12-4X	53-452-3	—	—	47-16-1-8X	—	—
-28	53-19-12-4X	53-452-3	—	—	47-16-1-8X	—	—
-29	53-19-7-4X	53-452-3	—	—	47-16-1-8X	—	—
-30	53-19-12-4X	53-452-4	53-453-2	4-4-4491	47-16-1-11X	—	—
-31	53-19-12-4X	53-452-3	—	—	47-16-1-8X	—	—
-32	53-19-7-4X	53-452-3	—	—	47-16-1-8X	—	—
-33	53-19-12-4X	—	—	53-106-2	47-16-1-13X	47-16-3-1X	—
-34	53-19-12-4X	—	—	—	47-16-1-8X	—	47-16-8-2X
-35	53-19-13-2X	—	—	—	47-16-1-8X	—	—
-36	53-19-15-2X	—	—	—	47-16-1-8X	—	—
-37	53-19-17-2X	—	—	—	47-16-1-8X	—	—
-38	53-19-13-2X	—	—	—	47-16-1-8X	—	—
-39	53-19-15-2X	—	—	—	47-16-1-8X	—	—
-40	53-19-17-2X	—	—	—	47-16-1-8X	—	—
-41	53-19-12-4X	—	—	—	47-16-1-8X	—	—
-42	53-19-13-2X	—	—	—	47-16-1-8X	—	—
-43	53-19-15-2X	—	—	—	47-16-1-8X	—	—
-44	53-19-17-2X	—	—	—	47-16-1-8X	—	—
-45	53-19-12-4X	—	—	—	47-16-1-8X	47-16-3-1X	—
-46	53-19-7-4X	53-452-3	—	—	47-16-1-8X	—	—
-47	53-19-12-4X	53-452-3	—	—	47-16-1-8X	—	—
-48	53-19-3-4X	53-452-2	—	53-106-2	47-16-1-8X	47-16-5-21X	—
-49	53-19-7-4X	53-452-4	53-453-2	—	47-16-1-11X	—	—
-50	53-19-12-4X	53-452-3	62-453-4	53-106-2	47-16-1-11X	—	—
-51	53-19-22-1X	53-452-6	—	4-4-4611-2	47-16-1-8X	—	—
-52	53-19-22-1X	53-452-6	—	5-4-6481-1	47-16-1-8X	—	—
-53	53-19-22-1X	53-452-6	—	4-4-4611-2	47-16-1-8X	—	—
-54	53-19-22-1X	53-452-6	—	5-4-6481-1	47-16-1-8X	—	—
-55	53-19-22-1X	53-452-6	—	5-4-6481-1	47-16-1-8X	—	—
-56	53-19-12-4X	53-452-4	53-453-2	4-4-4491	47-16-1-11X	—	—
-57	53-19-12-4X	53-452'4	53-453-2	4-4-4491	47-16-1-8X	47-16-5-43X	—

MODEL CM59

T210-ES60-5

TABULATED BILLS OF MATERIAL

Tab No.	Used By	For Use With Clutch 13" or 14" Single or 2PL	CLUTCH HOUSING			Main Drive Gear A-1	Drive Gear Bearing Cap F-2	Main Case Assembly G-1
			S A E	Assembly No. E-2	Rel. Code Pages 20-21			
Model 5952-A								
301360								
-1	Navistar	Pull Type	2	46-518-22-1X	8	59-35-3	53-19-11-1X	59-15-7-2X
-2	Service	Push Type	2	46-518-22-1X	26	59-35-3	47-19-82-1X	59-15-3-2X
-3	Never released for production							
-4	Never released for production							
-5	Navistar	Push Type	2	46-518-23	—	59-35-5	47-19-77-1X	59-15-7-2X
-6	Navistar	Push Type	2	46-518-23	—	59-35-5	47-19-77-1X	59-15-7-2X
-7	Never released for production							
-8	Never released for production							
-9	Volvo-GM	Push Type	2	46-518-22-1X	—	59-35-3	47-19-82-1X	59-15-3-2X
-10	Vermear Mfg.	Push Type	2	46-518-22-1X	26	59-35-3	47-19-82-1X	59-15-3-2X
-11	Service	Push Type	2	46-518-22-1X	26	59-35-3	47-19-78-1X	59-15-3-2X
-12	Never released for production							
-13	Never released for production							
-14	FWD Corp.	Push Type	2	46-518-22-1X	28	59-35-3	47-19-82-1X	59-15-3-2X
-15	Hendrickson	Push Type	2	46-518-22-1X	28	59-35-3	47-19-82-1X	59-15-10-2X
-16	Volvo-GM	Push Type	—	—	—	59-35-4	47-19-79-1X	59-15-3-2X
-17	Never released for production							
-18	Navistar	Pull Type	2	47-518-4-1X	—	59-35-2	53-19-11-1X	59-15-7-2X
-19	Navistar	Pull Type	2	47-518-4-1X	—	59-35-2	53-19-11-1X	59-15-7-2X
-20	Hendrickson	Pull Type	2	47-518-4-1X	68	59-35-2	53-19-11-1X	59-15-10-2X
-21*	A.M. General	Push Type	2	46-518-22-1X	21	59-35-3	47-19-82-1X	59-15-3-2X
-22	General use	Push Type	3	46-518-21-1X	36	59-35-3	47-19-82-1X	59-15-3-2X
-23	Wilson Mfg.	Pull Type	3	46-518-21-1X	8	59-35-3	53-19-11-1X	59-15-3-2X
-24	Blue Bird Body	Push Type	2	312830X	56	59-35-3	47-19-78-1X	59-15-9-2X
-25	Never released for production							
-26	General use	Push Type	2	46-518-22-1X	—	59-35-3	47-19-82-1X	59-15-3-2X
-27	Navistar	Pull Type	2	46-518-4-1X	—	59-35-9	53-19-11-1X	59-15-7-2X
-28	Never released for production							
-29	Cooper Mfg.	Push Type	3	46-518-21-1X	49	59-35-3	47-19-82-1X	59-15-3-2X
-30	Oshkosh Corp.	Push Type	2	46-518-22-1X	—	59-35-3	47-19-82-1X	59-15-3-2X
-31	FWD Corp.	Push Type	—	—	—	59-35-5	47-19-77-1X	59-15-3-2X
-32	Drivetrain	Push Type	—	—	—	59-35-3	47-19-82-1X	59-15-3-2X
-33	Never released for production							
-34	FWD Corp.	Push Type	2	46-518-22-1X	54	59-35-3	47-19-78-1X	59-15-3-2X
-35	Canadian Foremost	Push Type	3	46-518-21-1X	57	59-35-3	47-19-82-1X	59-15-3-2X
-36	Volvo-GM	Push Type	—	—	—	59-35-4	47-19-79-1X	59-15-3-2X
-37	Cooper Mfg.	Pull Type	2	46-518-22-1X	3	59-35-3	53-19-11-1X	59-15-3-2X
-38	Never released for production							
-39	Navistar	Pull Type	2	47-518-4-1X	—	59-35-9	53-19-11-1X	59-15-7-2X
-40	Drivetrain	Pull Type	2	47-518-4-1X	62	59-35-2	53-19-11-1X	59-15-3-2X
-41	Wich-Tex	Pull Type	2	46-518-22-1X	12	59-35-3	53-19-11-1X	59-15-3-2X
-42	Canadian Foremost	Push Type	3	46-518-21-1X	57	59-35-3	47-19-82-1X	59-15-3-2X
-43	Gradall	Pull Type	2	47-518-4-1X	67	59-35-2	53-19-11-1X	59-15-7-2X
-44	Never released for production							
-45	Never released for production							
-46	Never released for production							
-47	Wich-Tex	Pull Type	3	46-518-21-1X	12	59-35-3	53-19-11-1X	59-15-3-2X
-48	Never released for production							
-49*	Thomas Built Buses	Push Type	2	46-518-22-1X	55	59-35-3	47-19-78-1X	59-15-7-2X
-50	Never released for production							

* Includes Neutral Safety Switch Kit 313262X - Shipped loose

PARTS LISTED IN THIS CATALOG MAY NO LONGER BE AVAILABLE, USE WITH TRANSMISSION SUPERSEDING LIST.

MODEL CM59

TABULATED BILLS OF MATERIAL

T210-ES60-5

Tab No.	Rear Bearing Cap Assembly Cap, Seal and Bushing H-1	SPEEDOMETER		End Yoke or Companion Flange B-22	SHIFTER		
		Drive Gear B-21	Driven Gear H-8		Housing Ass'y Pages 14-15	Lever & Dome Ass'y Page 19	Remote Control Pages 16-18
Model 5952-A							
301360							
-1	53-19-1-4X	—	—	—	47-16-1-8X	47-16-3-1X	—
-2	53-19-12-4X	—	—	—	47-16-1-8X	47-16-3-1X	—
-3	Never released for production						
-4	Never released for production						
-5	53-19-1-4X	53-452-2	—	—	47-16-1-8X	—	—
-6	53-19-3-4X	53-452-2	—	—	47-16-1-8X	—	—
-7	Never released for production						
-8	Never released for production						
-9	53-19-12-4X	53-452-3	—	—	47-16-1-8X	—	—
-10	53-19-12-4X	—	—	—	47-16-1-8X	—	47-16-8-2X
-11	53-19-12-4X	—	—	—	47-16-1-8X	47-16-3-1X	—
-12	Never released for production						
-13	Never released for production						
-14	53-19-12-4X	—	—	—	47-16-1-8X	—	—
-15	53-19-12-4X	53-452-3	62-453-4	5-4-6321	47-16-1-11X	—	47-16-8-2X
-16	53-19-12-4X	—	—	—	—	—	—
-17	Never released for production						
-18	53-19-1-4X	53-452-2	—	—	47-16-1-8X	—	—
-19	53-19-3-4X	53-452-2	—	—	47-16-1-8X	—	—
-20	53-19-12-4X	53-452-3	62-453-4	5-4-6321	47-16-1-11X	—	47-16-8-2X
-21	53-19-12-4X	53-452-3	62-453-4	5-4-6321	47-16-1-8X	—	—
-22	53-19-12-4X	—	—	—	47-16-1-8X	47-16-3-1X	—
-23	53-19-12-4X	—	—	—	47-16-1-8X	47-16-3-1X	—
-24	53-19-12-4X	53-452-3	62-453-4	—	47-16-1-11X	—	—
-25	Never released for production						
-26	53-19-12-4X	53-452-3	62-453-4	—	47-16-1-8X	—	—
-27	53-19-1-4X	53-452-3	—	—	47-16-1-8X	—	—
-28	Never released for production						
-29	53-19-12-4X	—	—	—	47-16-1-16X	—	—
-30	53-19-12-4X	53-452-3	62-453-4	—	47-16-1-8X	47-16-3-25X	—
-31	53-19-12-4X	—	—	—	47-16-1-8X	—	—
-32	53-19-12-4X	—	—	—	47-16-1-8X	—	—
-33	Never released for production						
-34	53-19-12-4X	—	—	—	47-16-1-8X	—	—
-35	53-19-12-4X	—	—	53-106-2	47-16-1-8X	—	47-16-8-2X
-36	53-19-12-4X	—	—	—	47-16-1-10X	—	—
-37	53-19-12-4X	—	—	—	47-16-1-8X	—	47-16-8-2X
-38	Never released for production						
-39	53-19-3-4X	53-452-2	—	—	47-16-1-8X	—	—
-40	53-19-12-4X	—	—	—	47-16-1-8X	—	—
-41	53-19-12-4X	—	—	—	47-16-1-8X	47-16-3-1X	—
-42	53-19-12-4X	—	—	—	47-16-1-8X	—	—
-43	53-19-12-4X	—	—	5-4-6321	47-16-1-11X	—	47-16-8-2X
-44	Never released for production						
-45	Never released for production						
-46	Never released for production						
-47	53-19-12-4X	—	—	—	47-16-1-8X	47-16-3-1X	—
-48	Never released for production						
-49	53-19-12-4X	—	—	5-4-6321	47-16-1-11X	—	47-16-9-2X
-50	Never released for production						

MODEL CM59

T210-ES60-5

TABULATED BILLS OF MATERIAL

Tab No.	Used By	For Use With Clutch 13" or 14" Single or 2PL	CLUTCH HOUSING			Main Drive Gear A-1	Drive Gear Bearing Cap F-2	Main Case Assembly G-1
			S A E	Assembly No. E-2	Rel. Code Pages 20-21			
Model 5952-A								
301360 (Cont'd)								
-51	Spicer France	Push Type	—	—	—	59-35-3	47-19-78-1X	59-15-7-2X
-52	Volvo-GM	Push Type	2	46-518-13-1X	—	59-35-4	47-19-79-1X	59-15-3-2X
-53	Badger Equipment	Push Type	2	46-518-22-1X	53	59-35-3	47-19-78-1X	59-15-7-2X
-54	Never released for production							
-55	Badger Equipment	Push Type	2	46-518-22-1X	50	59-35-3	47-19-78-1X	59-15-7-2X
-56	Azcon Inc.	Pull Type	2	47-518-4-1X	62	59-35-2	53-19-11-1X	59-15-3-2X
-57	Ford	Push Type	—	—	—	59-35-6	47-19-73-1X	59-15-5-2X
-58	Ford	Push Type	—	—	—	59-35-6	49-19-73-1X	59-15-5-2X
-59	Ford	Push Type	—	—	—	59-35-6	47-19-73-1X	59-15-5-2X
-60	Ford	Push Type	2	47-518-5	—	59-35-7	47-19-74-1X	59-15-1-2X
-61	Ford	Push Type	2	47-518-5	—	59-35-7	47-19-74-1X	59-15-1-2X
-62	Ford	Push Type	2	47-518-5	—	59-35-7	47-19-74-1X	59-15-1-2X
-63	Never released for production							
-64	Never released for production							
-65	Never released for production							
-66	Ardco Inc.	Push Type	3	46-518-21-1X	19	59-35-3	47-19-82-1X	59-15-3-2X
-67	Ford	Pull Type	2	47-518-4-1X	—	59-35-2	53-19-11-1X	59-15-1-2X
-68	Ford	Pull Type	2	47-518-4-1X	—	59-35-2	53-19-11-1X	59-15-1-2X
-69	Ford	Pull Type	2	47-518-4-1X	—	59-35-2	53-19-11-1X	59-15-1-2X
-70	D.W.T.	Push Type	2	46-518-22-1X	26	59-35-3	47-19-82-1X	59-15-3-2X
-71	Volvo-GM	Push Type	2	47-518-10-1X	—	59-35-4	47-19-79-1X	59-15-3-2X
-72	D.W.T.	Push Type	2	47-518-5	—	59-35-7	47-19-74-1X	59-15-3-2X
-73	Vermeer Mfg.	Push Type	2	46-518-22-1X	26	59-35-3	47-19-82-1X	59-15-3-2X
-74	Never released for production							
-75	Never released for production							
-76	Never released for production							
-77	Davey-Kent	Pull Type	—	—	—	59-35-18	53-19-11-1X	59-15-3-2X
-78	D.W.T.	Push Type	3	46-518-21-1X	22	59-35-3	47-19-82-1X	59-15-3-2X
-79	Never released for production							
-80	Never released for production							
-81	Wilson Mfg.	Pull Type	2	46-518-22-1X	8	59-35-3	53-19-11-1X	59-15-3-2X
-82	Australia	Push Type	2	46-518-22-1X	51	59-35-3	49-19-82-1X	59-15-3-2X
-83	Volvo-GM	Push Type	2	47-518-10-1X	—	59-35-4	47-19-79-1X	59-15-3-2X
-84	Davey-Kent	Pull Type	—	—	—	59-35-18	53-19-11-1X	59-15-3-2X
-85	Capitol Trencher	Pull Type	—	—	—	59-35-2	53-19-11-1X	59-15-5-2X
-86	Never released for production							
-87	Spicer France	Push Type	—	—	—	59-35-3	47-19-78-1X	59-15-7-2X
-88	Stockdale Mine	Pull Type	2	313216	—	59-35-18	53-19-11-1X	59-15-3-2X
-89	Never released for production							
-90	Salem Tool	Pull Type	2	47-518-4-1X	63	59-35-9	53-19-11-1X	53-15-3-2X
-91	Never released for production							
-92	Never released for production							
-93	Never released for production							
-94	Never released for production							
-95	Volvo-GM	Push Type	2	312256X	—	59-35-10	47-19-80-1X	59-15-3-2X
-96	Never released for production							
-97	Never released for production							
-98	Never released for production							
-99	Volvo-GM	Pull Type	2	47-518-4-1X	2	59-35-2	53-19-11-1X	59-15-3-2X
-100	Never released for production							
-101	Never released for production							

PARTS LISTED IN THIS CATALOG MAY NO LONGER BE AVAILABLE, USE WITH TRANSMISSION SUPERSEDING LIST.

MODEL CM59

TABULATED BILLS OF MATERIAL

T210-ES60-5

Tab No.	Rear Bearing Cap Assembly Cap, Seal and Bushing H-1	SPEEDOMETER		End Yoke or Companion Flange B-22	SHIFTER		
		Drive Gear B-21	Driven Gear H-8		Housing Ass'y Pages 14-15	Lever & Dome Ass'y Page 19	Remote Control Pages 16-18
Model 5952-A							
301360 (Cont'd)							
-51	53-19-12-4X	53-452-4	53-453-2	4-4-4491	47-16-1-11X	—	—
-52	53-19-12-4X	53-452-3	—	—	47-16-1-8X	—	—
-53	53-19-12-4X	—	—	5-4-6321	47-16-1-11X	—	47-16-8-2X
-54	Never released for production						
-55	53-19-12-4X	—	—	5-4-6321	47-16-1-11X	—	47-16-8-2X
-56	53-19-12-4X	—	—	53-106-2	47-16-1-8X	47-16-3-1X	—
-57	53-19-13-2X	—	—	—	47-16-1-8X	—	—
-58	53-19-15-2X	—	—	—	47-16-1-8X	—	—
-59	53-19-17-2X	—	—	—	47-16-1-8X	—	—
-60	53-19-13-2X	—	—	—	47-16-1-8X	—	—
-61	53-19-15-2X	—	—	—	47-16-1-8X	—	—
-62	53-19-17-2X	—	—	—	47-16-1-8X	—	—
-63	Never released for production						
-64	Never released for production						
-65	Never released for production						
-66	53-19-12-4X	—	—	53-106-1	47-16-1-8X	47-16-5-38X	—
-67	53-19-13-2X	—	—	—	47-16-1-8X	—	—
-68	53-19-15-2X	—	—	—	47-16-1-8X	—	—
-69	53-19-17-2X	—	—	—	47-16-1-8X	—	—
-70	53-19-12-4X	53-452-3	62-453-4	5-4-6321	47-16-1-8X	47-16-3-1X	—
-71	53-19-7-4X	53-452-3	—	—	47-16-1-8X	—	—
-72	53-19-12-4X	53-452-3	62-453-4	5-4-6321	47-16-1-8X	47-16-3-1X	—
-73	53-19-12-4X	—	—	—	47-16-1-16X	—	—
-74	Never released for production						
-75	Never released for production						
-76	Never released for production						
-77	53-19-12-4X	—	—	53-106-2	47-16-1-16X	—	—
-78	53-19-12-4X	53-452-3	62-453-4	53-106-2	47-16-1-8X	47-16-3-25X	—
-79	Never released for production						
-80	Never released for production						
-81	53-19-12-4X	—	—	—	47-16-1-8X	47-16-3-1X	—
-82	53-19-12-4X	53-452-3	62-453-4	—	47-16-1-8X	—	47-16-8-2X
-83	53-19-12-4X	53-452-3	—	—	47-16-1-8X	—	—
-84	53-19-12-4X	—	—	53-106-2	47-16-1-16X	47-16-3-1X	—
-85	53-19-13-2X	—	—	—	47-16-1-8X	—	—
-86	Never released for production						
-87	53-19-7-4X	53-452-4	53-453-2	—	47-16-1-11X	—	—
-88	53-19-12-4X	—	—	3-4-8781	47-16-1-16X	47-16-3-1X	—
-89	Never released for production						
-90	53-19-12-4X	—	—	—	47-16-1-8X	—	—
-91	Never released for production						
-92	Never released for production						
-93	Never released for production						
-94	Never released for production						
-95	53-19-12-4X	53-452-3	—	—	47-16-1-8X	—	—
-96	Never released for production						
-97	Never released for production						
-98	Never released for production						
-99	53-19-12-4X	53-452-3	—	—	47-16-1-8X	—	—
-100	Never released for production						
-101	Never released for production						

MODEL CM59

T210-ES60-5

TABULATED BILLS OF MATERIAL

Tab No.	Used By	For Use With Clutch 13" or 14" Single or 2PL	CLUTCH HOUSING			Main Drive Gear A-1	Drive Gear Bearing Cap F-2	Main Case Assembly G-1
			S A E	Assembly No. E-2	Rel. Code Pages 20-21			
Model 5952-A								
301360 (Cont'd)								
-102	Never released for production							
-103	Ford	Push Type	—	—	—	59-35-6	47-19-73-1X	59-15-5-2X
-104	Ford	Push Type	—	—	—	59-35-6	47-19-73-1X	59-15-5-2X
-105	Ford	Push Type	2	47-518-5	—	59-35-7	47-19-74-1X	59-15-1-2X
-106	Ford	Push Type	2	47-518-5	—	59-35-7	47-19-74-1X	59-15-1-2X
-107	Ford	Pull Type	2	47-518-4-1X	—	59-35-2	53-19-11-1X	59-15-1-1X
-108	Vermeer Mfg.	Push Type	2	47-518-22-1X	26	59-35-3	47-19-82-1X	59-15-3-2X
-109	Walker Neer Machine	Pull Type	2	46-518-22-1X	—	59-35-3	53-19-11-1X	59-15-3-2X
-110	Spicer France	Push Type	—	—	—	59-35-3	47-19-78-1X	59-15-7-2X
-111	Spicer France	Push Type	—	—	—	59-35-3	47-19-78-1X	59-15-7-2X
-112*	Thomas Built Buses	Pull Type	2	47-518-4-1X	—	59-35-2	53-19-11-1X	59-15-7-2X
-113	Gradall Co.	Push Type	2	46-518-22-1X	26	59-35-3	47-19-82-1X	59-15-7-2X
-114	Never released for production							
-115	Never released for production							
-116	Never released for production							
-117	Never released for production							
-118	Never released for production							
-119	Never released for production							
-120	Never released for production							
-121	Never released for production							
-122	Never released for production							
-123	Never released for production							
-124	Never released for production							
-125	Never released for production							
-126	Volvo-GM	Push Type	2	312256X	—	59-35-10	47-19-80-1X	59-15-3-2X
Model 5952C								
301362								
-1	Navistar	Pull Type	2	46-518-22-1X	8	59-35-3	53-19-11-1X	59-15-7-2X
-2	Volvo-GM	Push Type	2	46-518-22-1X	—	59-35-3	47-19-82-1X	59-15-3-2X
-3	Blue Bird	Push Type	2	312830X	56	59-35-3	47-19-78-1X	59-15-9-2X
-4	Gradall Co.	Push Type	2	46-518-22-1X	34	59-35-3	47-19-82-1X	59-15-7-2X
-5	Never released for production							
-6	Volvo-GM	Push Type	2	46-518-22-1X	—	59-35-3	47-19-82-1X	59-15-3-2X
-7	Gradall Co.	Push Type	3	46-518-21-1X	24	59-35-3	47-19-82-1X	59-15-7-2X
-8	Never released for production							
-9	Never released for production							
-10	Never released for production							
-11	Never released for production							
-12	Volvo-GM	Push Type	—	—	—	59-35-3	47-19-82-1X	59-15-3-2X
-13	Volvo-GM	Push Type	—	—	—	59-35-3	47-19-82-1X	59-15-3-2X
-14	Navistar	Push Type	2	46-518-23	—	59-35-3	47-19-77-1X	59-15-7-2X
-15	Volvo-GM	Push Type	2	46-518-22-1X	—	59-35-3	47-19-82-1X	59-15-3-2X
-16	Never released for production							
-17	Navistar	Pull Type	2	47-518-4-1X	—	59-35-2	53-19-11-1X	59-15-7-2X
-18	Drivetrain	Push Type	—	—	—	59-35-3	47-19-82-1X	59-15-3-2X
-19	Western Star Truck	Pull Type	2	47-518-4-1X	—	59-35-2	53-19-11-1X	59-15-3-2X
-20	Volvo-GM	Push Type	—	—	—	59-35-3	47-19-82-1X	59-15-3-2X
-21	Navistar	Pull Type	2	47-518-4-1X	—	59-35-2	53-19-11-1X	59-15-7-2X

* Includes Neutral Safety Switch Kit 313262X - Shipped loose

PARTS LISTED IN THIS CATALOG MAY NO LONGER BE AVAILABLE, USE WITH TRANSMISSION SUPERSEDING LIST.

MODEL CM59

TABULATED BILLS OF MATERIAL

T210-ES60-5

Tab No.	Rear Bearing Cap Assembly Cap, Seal and Bushing H-1	SPEEDOMETER		End Yoke or Companion Flange B-22	SHIFTER		
		Drive Gear B-21	Driven Gear H-8		Housing Ass'y Pages 14-15	Lever & Dome Ass'y Page 19	Remote Control Pages 16-18
Model 5952-A							
301360 (Cont'd)							
-102	Never released for production						
-103	53-19-22-1X	53-452-6	—	4-4-4611-2	47-16-1-8X	—	—
-104	53-19-22-1X	53-452-6	—	5-4-6481-1	47-16-1-8X	—	—
-105	53-19-22-1X	53-452-6	—	4-4-4611-2	47-16-1-8X	—	—
-106	53-19-22-1X	53-452-6	—	5-4-6481-1	47-16-1-8X	—	—
-107	53-19-22-1X	53-452-6	—	5-4-6481-1	47-16-1-8X	—	—
-108	53-19-12-4X	—	—	—	47-16-1-18X	—	—
-109	53-19-12-4X	—	—	53-106-1	47-16-1-8X	47-16-3-1X	—
-110	53-19-12-4X	53-452-4	53-453-2	4-4-4491	47-16-1-11X	—	—
-111	53-19-12-4X	53-452-4	53-453-2	4-4-4491	47-16-1-8X	47-16-5-43X	—
-112	53-19-12-4X	—	—	—	47-16-1-13X	—	—
-113	53-19-12-4X	—	—	5-4-6321	47-16-1-11X	—	—
-114	Never released for production						
-115	Never released for production						
-116	Never released for production						
-117	Never released for production						
-118	Never released for production						
-119	Never released for production						
-120	Never released for production						
-121	Never released for production						
-122	Never released for production						
-123	Never released for production						
-124	Never released for production						
-125	Never released for production						
-126	53-19-7-4X	53-452-3	—	—	47-16-1-8X	—	—
Model 5952C							
301362							
-1	53-19-1-4X	—	—	—	47-16-1-8X	47-16-3-1X	—
-2	53-19-12-4X	53-452-3	—	—	47-16-1-8X	—	—
-3	53-19-12-4X	53-452-3	62-453-4	—	47-16-1-11X	—	—
-4	53-19-12-4X	—	—	5-4-6321	47-16-1-11X	—	47-16-8-2X
-5	Never released for production						
-6	53-19-7-4X	53-452-3	—	—	47-16-1-8X	—	—
-7	53-19-12-4X	—	—	5-4-6321	47-16-1-11X	—	47-16-8-2X
-8	Never released for production						
-9	Never released for production						
-10	Never released for production						
-11	Never released for production						
-12	53-19-12-4X	—	—	—	—	—	—
-13	53-19-7-4X	—	—	—	—	—	—
-14	53-19-1-4X	53-452-2	—	—	47-16-1-10X	—	—
-15	53-19-12-4X	53-452-3	—	53-106-2	47-16-1-8X	—	—
-16	Never released for production						
-17	53-19-3-4X	53-452-2	—	—	47-16-1-8X	—	—
-18	53-19-12-4X	—	—	—	47-16-1-8X	—	—
-19	53-19-12-4X	—	—	—	47-16-1-8X	—	—
-20	53-19-12-4X	—	—	—	47-16-1-10X	—	—
-21	53-19-1-4X	—	—	—	47-16-1-8X	—	—

MODEL CM59

T210-ES60-5

TABULATED BILLS OF MATERIAL

Tab No.	Used By	For Use With Clutch 13" or 14" Single or 2PL	CLUTCH HOUSING			Main Drive Gear A-1	Drive Gear Bearing Cap F-2	Main Case Assembly G-1
			S A E	Assembly No. E-2	Rel. Code Pages 20-21			
Model 5952-C								
301362 (Cont'd)								
-22		Never released for production						
-23	Universal Go-Tract	Push Type	2	46-518-22-1X	34	59-35-3	47-19-82-1X	59-15-3-2X
-24	Drivetrain	Push Type	2	46-518-22-1X	—	59-35-3	47-19-82-1X	59-15-3-2X
-25	Volvo-GM	Push Type	2	46-518-13-1X	—	59-35-4	47-19-79-1X	59-15-3-2X
-26	Volvo-GM	Push Type	2	46-518-13-1X	—	59-35-4	47-19-79-1X	59-15-3-2X
-27		Never released for production						
-28	Volvo-GM	Push Type	2	46-518-13-1X	—	59-35-4	47-19-79-1X	59-15-3-2X
-29		Never released for production						
-30	Service	Push Type	2	46-518-22-1X	34	59-35-4	47-19-82-1X	59-15-7-2X
-31	Volvo-GM	Push Type	2	312256X	—	59-35-10	47-19-80-1X	59-15-3-2X
-32		Never released for production						
-33	Navistar	Pull Type	2	47-518-4-1X	—	59-35-9	53-19-11-1X	59-15-7-2X
-34	Gradall Co.	Push Type	2	46-518-22-1X	34	59-35-3	47-19-82-1X	59-15-7-2X
-35		Never released for production						
-36	Shear Truck	Push Type	2	46-518-22-1X	33	59-35-3	47-19-82-1X	59-15-9-2X
-37	FMC Corp.	Push Type	2	46-518-22-1X	20	59-35-3	47-19-82-1X	59-15-3-2X
-38	Volvo-GM	Push Type	2	47-518-10-1X	—	59-35-4	47-19-79-1X	59-15-3-2X
-39	Volvo-GM	Push Type	2	47-518-10-1X	—	59-35-4	47-19-79-1X	59-15-3-2X
-40	Volvo-GM	Push Type	2	47-518-10-1X	—	59-35-4	47-19-79-1X	59-15-3-2X
-41	Volvo-GM	Push Type	2	312256X	—	59-35-10	47-19-80-1X	59-15-3-2X
-42	Navistar	Pull Type	2	47-518-4-1X	—	59-35-9	53-19-11-1X	59-15-7-2X
-43	Ford	Push Type	2	47-518-5	—	59-35-7	47-19-74-1X	59-15-1-2X
-44	Ford	Push Type	2	47-518-5	—	59-35-7	47-19-74-1X	59-15-1-2X
-45	Ford	Push Type	2	47-518-5	—	59-35-7	47-19-74-1X	59-15-1-2X
-46	Ford	Push Type	—	—	—	59-35-6	47-19-73-1X	59-15-5-2X
-47	Ford	Push Type	—	—	—	59-35-6	47-19-73-1X	59-15-5-2X
-48	Ford	Push Type	—	—	—	59-35-6	47-19-73-1X	59-15-5-2X
-49	Service	Pull Type	2	47-518-4-1X	70	59-35-2	53-19-11-1X	59-15-3-2X
-50	Ford	Pull Type	2	47-518-4-1X	—	59-35-2	53-19-11-1X	59-15-1-2X
-51	Service	Pull Type	2	46-518-22-1X	8	59-35-3	53-19-11-1X	59-15-3-2X
-52	Ford	Pull Type	2	47-518-4-1X	—	59-35-2	53-19-11-1X	59-15-1-1X
-53	Ford	Pull Type	2	47-518-4-1X	—	59-35-2	53-19-11-1X	59-15-1-1X
-54	Universal Go-Tract	Push Type	3	46-518-21-1X	34	59-35-3	47-19-82-1X	59-15-3-2X
-55	Universal Go-Tract	Push Type	—	—	34	59-35-3	47-19-82-1X	59-15-3-2X
-56	Service	Pull Type	2	46-518-22-1X	—	59-35-3	53-19-11-1X	59-15-3-2X
-57		Never released for production						
-58		Never released for production						
-59		Never released for production						
-60	Universal Go-Tract	Push Type	3	46-518-21-1X	34	59-35-3	47-19-82-1X	59-15-3-2X
-61	Thomas Built Buses	Pull Type	2	47-518-4-1X	75	59-35-2	53-19-11-1X	59-15-7-2X
-62		Never released for production						
-63		Never released for production						
-64		Never released for production						
-65		Never released for production						
-66		Never released for production						
-67		Never released for production						
-68		Never released for production						
-69	Volvo-GM	Pull Type	2	47-518-4-1X	—	59-35-2	53-19-11-1X	59-15-3-2X
-70	Tree Farmer	Push Type	3	46-518-21-1X	—	59-35-3	47-19-82-1X	59-15-3-2X

PARTS LISTED IN THIS CATALOG MAY NO LONGER BE AVAILABLE, USE WITH TRANSMISSION SUPERSEDING LIST.

MODEL CM59

TABULATED BILLS OF MATERIAL

T210-ES60-5

Tab No.	Rear Bearing Cap Assembly Cap, Seal and Bushing H-1	SPEEDOMETER		End Yoke or Companion Flange B-22	SHIFTER		
		Drive Gear B-21	Driven Gear H-8		Housing Ass'y Pages 14-15	Lever & Dome Ass'y Page 19	Remote Control Pages 16-18
Model 5952-C							
301362 (Cont'd)							
-22	Never released for production						
-23	53-19-12-4X	—	—	53-106-2	47-16-1-11X	—	—
-24	53-19-12-4X	—	—	53-106-2	47-16-1-8X	47-16-3-1X	—
-25	53-19-7-4X	53-452-3	—	—	47-16-1-8X	—	—
-26	53-19-12-4X	53-452-3	—	—	47-16-1-8X	—	—
-27	Never released for production						
-28	53-19-12-4X	53-452-3	—	5-4-6321	47-16-1-8X	—	—
-29	Never released for production						
-30	53-19-12-4X	53-452-3	62-453-4	5-4-6321	47-16-1-11X	47-16-3-1X	—
-31	53-19-12-4X	53-452-3	—	—	47-16-1-8X	—	—
-32	Never released for production						
-33	53-19-3-4X	53-452-2	—	—	47-16-1-8X	—	—
-34	53-19-12-4X	—	—	5-4-6321	47-16-1-11X	—	—
-35	Never released for production						
-36	53-19-12-4X	53-452-3	62-453-4	53-106-2	47-16-1-8X	47-16-5-21X	—
-37	53-19-12-4X	—	—	—	47-16-1-8X	47-16-3-1X	—
-38	53-19-7-4X	53-452-3	—	—	47-16-1-8X	—	—
-39	53-19-12-4X	53-452-3	—	—	47-16-1-8X	—	—
-40	53-19-12-4X	53-452-3	—	—	47-16-1-8X	—	—
-41	53-19-7-4X	53-452-3	—	—	47-16-1-8X	—	—
-42	53-19-1-4X	53-452-2	—	—	47-16-1-8X	—	—
-43	53-19-13-2X	—	—	—	47-16-1-8X	—	—
-44	53-19-15-2X	—	—	—	47-16-1-8X	—	—
-45	53-19-17-2X	—	—	—	47-16-1-8X	—	—
-46	53-19-13-2X	—	—	—	47-16-1-8X	—	—
-47	53-19-15-2X	—	—	—	47-16-1-8X	—	—
-48	53-19-17-2X	—	—	—	47-16-1-8X	—	—
-49	53-19-12-4X	53-452-3	62-453-4	53-106-2	47-16-1-8X	47-16-3-1X	—
-50	53-19-13-2X	—	—	—	47-16-1-8X	—	—
-51	53-19-12-4X	—	—	—	47-16-1-8X	47-16-3-1X	—
-52	53-19-17-2X	—	—	—	47-16-1-8X	—	—
-53	53-19-15-2X	—	—	—	47-16-1-8X	—	—
-54	53-19-12-4X	—	—	53-106-2	47-16-1-11X	—	—
-55	53-19-12-4X	—	—	53-106-2	47-16-1-11X	—	—
-56	53-19-12-4X	—	—	—	47-16-1-8X	—	—
-57	Never released for production						
-58	Never released for production						
-59	Never released for production						
-60	53-19-12-4X	—	—	53-106-2	47-16-1-11X	—	—
-61	53-19-12-4X	—	—	—	47-16-1-13X	—	—
-62	Never released for production						
-63	Never released for production						
-64	Never released for production						
-65	Never released for production						
-66	Never released for production						
-67	Never released for production						
-68	Never released for production						
-69	53-19-12-4X	53-452-3	—	—	47-16-1-8X	—	—
-70	53-19-12-4X	—	—	4-4-4491	47-16-1-17X	—	—

MODEL CM59

T210-ES60-5

TABULATED BILLS OF MATERIAL

Tab No.	Used By	For Use With Clutch 13" or 14" Single or 2PL	CLUTCH HOUSING			Main Drive Gear A-1	Drive Gear Bearing Cap F-2	Main Case Assembly G-1
			S A E	Assembly No. E-2	Rel. Code Pages 20-21			
Model 5952-D								
301363								
-1	Navistar	Pull Type	2	46-518-22-1X	8	59-35-3	53-19-11-1X	59-15-7-2X
-2	Never released for production							
-3	Navistar	Push Type	2	46-518-23	—	59-35-5	47-19-77-1X	59-15-7-2X
-4	Navistar	Pull Type	2	47-518-4-1X	—	59-35-9	53-19-11-1X	59-15-7-2X
-5	Navistar	Pull Type	2	47-518-4-1X	—	59-35-9	53-19-11-1X	59-15-7-2X
-6	Volvo-GM	Push Type	2	47-518-10-1X	—	59-35-4	47-19-79-1X	59-15-3-2X
-7	Volvo-GM	Push Type	2	47-518-10-1X	—	59-35-4	47-19-79-1X	59-15-3-2X
-8	Volvo-GM	Push Type	2	47-518-13-1X	—	59-35-4	47-19-79-1X	59-15-3-2X
-9	Volvo-GM	Push Type	2	47-518-13-1X	—	59-35-4	47-19-79-1X	59-15-3-2X
-10	Volvo-GM	Push Type	2	312256X	—	59-35-10	47-19-80-1X	59-15-3-2X
-11	Never released for production							
-12	Volvo-GM	Push Type	2	312256X	—	59-35-10	47-19-80-1X	59-15-3-2X
-13	Ford	Push Type	2	47-518-5	—	59-35-7	47-19-74-1X	59-15-1-1X
-14	Ford	Push Type	2	47-518-5	—	59-35-7	47-19-74-1X	59-15-1-1X
-15	Ford	Push Type	2	47-518-5	—	59-35-7	47-19-74-1X	59-15-1-2X
-16	Ford	Pull Type	2	47-518-4-1X	—	59-35-2	53-19-11-1X	59-15-1-2X
-17	Ford	Pull Type	2	47-518-4-1X	—	59-35-2	53-19-11-1X	59-15-1-2X
-18	Ford	Pull Type	2	47-518-4-1X	—	59-35-2	53-19-11-1X	59-15-1-2X
-19	Ford	Push Type	—	—	—	59-35-6	47-19-73-1X	59-15-5-2X
-20	Ford	Push Type	—	—	—	59-35-6	47-19-73-1X	59-15-5-2X
-21	Navistar	Pull Type	2	46-518-22-1X	8	59-35-3	53-19-11-1X	59-15-3-2X
-22	Ford	Push Type	—	—	—	59-35-6	47-19-73-1X	59-15-5-2X
-23	Ford	Pull Type	2	47-518-4-1X	—	59-35-2	53-19-11-1X	59-15-3-2X
-24	Volvo-GM	Pull Type	2	47-518-4-1X	—	59-35-2	53-19-11-1X	59-15-3-2X
-25	Diesel Equipment	Push Type	2	46-518-22-1X	51	59-35-3	47-19-82-1X	59-15-3-2X
-26	Navistar	Push Type	2	46-518-23	—	59-35-5	47-19-77-1X	59-15-7-2X
-27	Badger Equipment	Pull Type	2	47-518-4-1X	67	59-35-9	53-19-11-1X	59-15-3-2X
-28	D.W.T.	Pull Type	2	47-518-4-1X	70	59-35-2	53-19-11-1X	59-15-3-2X
-29	Never released for production							
-30	Never released for production							
-31	Never released for production							
-32	Navistar	Pull Type	2	47-518-4-1X	—	59-35-9	53-19-11-1X	59-15-7-2X
-33	Navistar	Pull Type	2	47-518-4-1X	—	59-35-9	53-19-11-1X	59-15-7-2X
-34	Never released for production							
-35	Never released for production							
-36	Never released for production							
-37	Never released for production							
-38	Never released for production							
-39	Never released for production							
-40	Never released for production							
-41	Navistar	Pull Type	2	47-518-4-1X	—	59-35-9	53-19-11-1X	59-15-7-2X
-42	Navistar	Pull Type	2	47-518-4-1X	—	59-35-9	53-19-11-1X	59-15-7-2X

Model 5952E

301364

- 1 Never released for production
- 2 Never released for production
- 3 Never released for production
- 4 Never released for production

MODEL CM59

TABULATED BILLS OF MATERIAL

T210-ES60-5

Tab No.	Rear Bearing Cap Assembly Cap, Seal and Bushing H-1	SPEEDOMETER		End Yoke or Companion Flange B-22	SHIFTER		
		Drive Gear B-21	Driven Gear H-8		Housing Ass'y Pages 14-15	Lever & Dome Ass'y Page 19	Remote Control Pages 16-18
Model 5952-D							
301363							
-1	53-19-1-4X	—	—	—	47-16-1-8X	47-16-3-1X	—
-2	Never released for production						
-3	53-19-3-4X	53-452-2	—	—	47-16-1-8X	—	—
-4	53-19-3-4X	53-452-2	—	—	47-16-1-8X	—	—
-5	53-19-1-4X	53-452-2	—	—	47-16-1-8X	—	—
-6	53-19-7-4X	53-452-3	—	—	47-16-1-8X	—	—
-7	53-19-12-4X	53-452-3	—	—	47-16-1-8X	—	—
-8	53-19-12-4X	53-452-3	—	—	47-16-1-8X	—	—
-9	53-19-7-4X	53-452-3	—	—	47-16-1-8X	—	—
-10	53-19-12-4X	53-452-3	—	—	47-16-1-8X	—	—
-11	Never released for production						
-12	53-19-7-4X	53-452-3	—	—	47-16-1-8X	—	—
-13	53-19-13-2X	—	—	—	47-16-1-8X	—	—
-14	53-19-15-2X	—	—	—	47-16-1-8X	—	—
-15	53-19-17-2X	—	—	—	47-16-1-8X	—	—
-16	53-19-13-2X	—	—	—	47-16-1-8X	—	—
-17	53-19-17-2X	—	—	—	47-16-1-8X	—	—
-18	53-19-15-2X	—	—	—	47-16-1-8X	—	—
-19	53-19-15-2X	—	—	—	47-16-1-8X	—	—
-20	53-19-17-2X	—	—	—	47-16-1-8X	—	—
-21	53-19-12-4X	—	—	—	47-16-1-8X	47-16-3-1X	—
-22	53-19-13-2X	—	—	—	47-16-1-8X	—	—
-23	53-19-12-2X	53-452-3	—	—	47-16-1-8X	—	—
-24	53-19-7-2X	53-452-3	—	—	47-16-1-8X	—	—
-25	53-19-12-4X	—	—	53-106-2	47-16-1-8X	47-16-3-1X	—
-26	53-19-1-4X	53-452-2	—	—	47-16-1-8X	—	—
-27	53-19-12-4X	—	—	5-4-6321	47-16-1-8X	—	47-16-8-2X
-28	53-19-12-4X	53-452-3	62-453-4	—	47-16-1-8X	47-16-3-25X	—
-29	Never released for production						
-30	Never released for production						
-31	Never released for production						
-32	53-19-3-4X	53-452-2	—	—	47-16-1-8X	—	—
-33	53-19-1-4X	53-452-2	—	—	47-16-1-8X	—	—
-34	Never released for production						
-35	Never released for production						
-36	Never released for production						
-37	Never released for production						
-38	Never released for production						
-39	Never released for production						
-40	Never released for production						
-41	53-19-26-2X	53-452-5	—	—	47-16-1-8X	—	—
-42	53-19-24-2X	53-452-5	—	—	47-16-1-8X	—	—

Model 5952E

301364

- 1 Never released for production
- 2 Never released for production
- 3 Never released for production
- 4 Never released for production

MODEL CM59

T210-ES60-5

TABULATED BILLS OF MATERIAL

Tab No.	Used By	For Use With Clutch 13" or 14" Single or 2PL	CLUTCH HOUSING			Main Drive Gear A-1	Drive Gear Bearing Cap F-2	Main Case Assembly G-1
			S A E	Assembly No. E-2	Rel. Code Pages 20-21			
Model 5952-E								
301364								
-5	Volvo-GM	Push Type	2	46-518-22-1X	—	59-35-1	47-19-82-1X	59-15-3-2X
-6	Navistar	Push Type	2	46-518-23	—	59-35-12	47-19-77-1X	59-15-7-2X
-7	Blue Bird Body	Push Type	2	312830X	56	59-35-1	47-19-78-1X	59-15-9-2X
-8	Volvo-GM	Push Type	2	312256X	—	59-35-15	47-19-80-1X	59-15-3-2X
-9	Volvo-GM	Push Type	2	46-518-22-1X	—	59-35-1	47-19-82-1X	59-15-3-2X
-10	Volvo-GM	Push Type	—	—	—	59-35-15	47-19-80-1X	59-15-3-2X
-11	Never released for production							
-12	Volvo-GM	Push Type	—	—	—	59-35-1	47-19-82-1X	59-15-3-2X
-13	Never released for production							
-14	Never released for production							
-15	Navistar	Pull Type	2	47-518-4-1X	—	59-35-14	53-19-11-1X	59-15-7-2X
-16	Navistar	Pull Type	2	47-518-4-1X	—	59-35-14	53-19-11-1X	59-15-7-2X
-17	Never released for production							
-18	Volvo-GM	Push Type	2	46-518-22-1X	—	59-35-1	47-19-82-1X	59-15-9-2X
-19	Volvo-GM	Push Type	2	46-518-22-1X	—	59-35-1	47-19-82-1X	59-15-9-2X
-20	Never released for production							
-21	Volvo-GM	Push Type	2	312256X	—	59-35-15	47-19-80-1X	59-15-9-2X
-22	Navistar	Pull Type	2	47-518-4-1X	—	59-35-16	53-19-11-1X	59-15-7-2X
-23	Volvo-GM	Push Type	—	—	—	59-35-1	47-19-82-1X	59-15-3-2X
-24	Canadian Foremost	Push Type	3	46-518-21-1X	57	59-35-1	47-19-82-1X	59-15-3-2X
-25	Service	Push Type	2	46-518-22-1X	—	59-35-1	47-19-82-1X	59-15-3-2X
-26	Drivetrain	Pull Type	—	—	—	59-35-1	53-19-11-1X	59-15-3-2X
-27	Drivetrain	Push Type	—	—	—	59-35-1	47-19-82-1X	59-15-3-2X
-28	Volvo-GM	Push Type	—	—	—	59-35-15	47-19-80-1X	59-15-3-2X
-29	Volvo-GM	Push Type	—	—	—	59-35-1	47-19-82-1X	59-15-3-2X
-30	Never released for production							
-31	Drivetrain	Pull Type	2	47-518-4-1X	62	59-35-14	53-19-11-1X	59-15-3-2X
-32	Volvo-GM	Push Type	2	312256X	—	59-35-15	47-19-80-1X	59-15-3-2X
-33	Navistar	Pull Type	2	47-518-4-1X	—	59-35-16	53-19-11-1X	59-15-7-2X
-34	Volvo-GM	Push Type	2	47-518-13-1X	—	59-35-13	47-19-79-1X	59-15-3-2X
-35	T.S.P.	Pull Type	2	46-518-22-1X	—	59-35-1	53-19-11-1X	59-15-3-2X
-36	Volvo-GM	Push Type	2	46-518-13-1X	—	59-35-13	47-19-79-1X	59-15-3-2X
-37	Volvo-GM	Push Type	2	46-518-13-1X	—	59-35-13	47-19-79-1X	59-15-3-2X
-38	Volvo-GM	Push Type	2	46-518-13-1X	—	59-35-13	47-19-79-1X	59-15-9-2X
-39	Volvo-GM	Push Type	2	46-518-13-1X	—	59-35-13	47-19-79-1X	59-15-9-2X
-40	Never released for production							
-41	Never released for production							
-42	Never released for production							
-43	Spicer France	Push Type	—	—	—	59-35-1	47-19-78-1X	59-15-7-2X
-44	Volvo-GM	Push Type	2	47-518-10-1X	—	59-35-13	47-19-79-1X	59-15-3-2X
-45	Volvo-GM	Push Type	2	47-518-10-1X	—	59-35-13	47-19-79-1X	59-15-3-2X
-46	Never released for production							
-47	Otis Engineering Corp.	Push Type	—	—	—	59-35-13	47-19-79-1X	59-15-3-2X
-48	Transquipment Incorp.	Push Type	3	46-518-21-1X	22	59-35-1	47-19-82-1X	59-15-3-2X
-49	Never released for production							
-50	Vermeer Mfg.	Push Type	2	46-518-22-1X	26	59-35-1	47-19-82-1X	59-15-3-2X
-51	Never released for production							
-52	Never released for production							
-53	Ford	Pull Type	—	—	—	59-35-11	47-19-73-1X	59-15-5-2X

PARTS LISTED IN THIS CATALOG MAY NO LONGER BE AVAILABLE, USE WITH TRANSMISSION SUPERSEDING LIST.

MODEL CM59

TABULATED BILLS OF MATERIAL

T210-ES60-5

Tab No.	Rear Bearing Cap Assembly Cap, Seal and Bushing H-1	SPEEDOMETER		End Yoke or Companion Flange B-22	SHIFTER		
		Drive Gear B-21	Driven Gear H-8		Housing Ass'y Pages 14-15	Lever & Dome Ass'y Page 19	Remote Control Pages 16-18
Model 5952-E							
301364							
-5	53-19-12-4X	53-452-3	—	—	47-16-1-8X	—	—
-6	53-19-3-4X	53-452-2	—	—	47-16-1-8X	—	—
-7	53-19-12-4X	53-452-3	62-453-4	—	47-16-1-11X	—	—
-8	53-19-12-4X	53-452-3	—	—	47-16-1-8X	—	—
-9	53-19-7-4X	53-452-3	—	—	47-16-1-8X	—	—
-10	53-19-12-4X	—	—	—	—	—	—
-11	Never released for production						
-12	53-19-12-4X	—	—	—	—	—	—
-13	Never released for production						
-14	Never released for production						
-15	53-19-1-4X	53-452-2	—	—	47-16-1-8X	—	—
-16	53-19-3-4X	53-452-2	—	—	47-16-1-8X	—	—
-17	Never released for production						
-18	53-19-7-4X	53-452-3	—	—	47-16-1-8X	—	—
-19	53-19-12-4X	53-452-3	—	—	47-16-1-8X	—	—
-20	Never released for production						
-21	53-19-12-4X	53-452-3	—	—	47-16-1-8X	—	—
-22	53-19-1-4X	53-452-2	—	—	47-16-1-8X	—	—
-23	53-19-7-4X	—	—	—	—	—	—
-24	53-19-12-4X	—	—	53-106-2	47-16-1-8X	—	—
-25	53-19-12-4X	—	—	—	47-16-1-8X	—	—
-26	53-19-12-4X	—	—	—	47-16-1-8X	47-16-3-1X	—
-27	53-19-12-4X	—	—	—	47-16-1-8X	—	—
-28	53-19-12-4X	—	—	—	47-16-1-10X	—	—
-29	53-19-12-4X	—	—	—	47-16-1-10X	—	—
-30	Never released for production						
-31	53-19-12-4X	—	—	—	47-16-1-8X	—	—
-32	53-19-7-4X	53-452-3	—	—	47-16-1-8X	—	—
-33	53-19-3-4X	53-452-2	—	—	47-16-1-8X	—	—
-34	53-19-12-4X	53-452-3	—	—	47-16-1-10X	—	—
-35	53-19-12-4X	53-452-3	62-453-4	53-106-2	47-16-1-12X	47-16-3-25X	—
-36	53-19-7-4X	53-452-3	—	—	47-16-1-8X	—	—
-37	53-19-12-4X	53-452-3	—	—	47-16-1-8X	—	—
-38	53-19-12-4X	53-452-3	—	—	47-16-1-8X	—	—
-39	53-19-7-4X	53-452-3	—	—	47-16-1-8X	—	—
-40	Never released for production						
-41	Never released for production						
-42	Never released for production						
-43	53-19-12-4X	53-452-4	53-453-2	4-4-4491	47-16-1-11X	—	—
-44	53-19-12-4X	53-452-3	—	—	47-16-1-8X	—	—
-45	53-19-7-4X	53-452-3	—	—	47-16-1-8X	—	—
-46	Never released for production						
-47	53-19-12-4X	53-452-3	62-453-4	5-4-6321	47-16-1-8X	47-16-3-1X	—
-48	53-19-12-4X	—	—	53-106-2	47-16-1-13X	47-16-3-1X	—
-49	Never released for production						
-50	53-19-12-4X	—	—	—	47-16-1-8X	—	47-16-8-2X
-51	Never released for production						
-52	Never released for production						
-53	53-19-13-2X	—	—	—	47-16-1-8X	—	—

MODEL CM59

T210-ES60-5

TABULATED BILLS OF MATERIAL

Tab No.	Used By	For Use With Clutch 13" or 14" Single or 2PL	CLUTCH HOUSING			Main Drive Gear A-1	Drive Gear Bearing Cap F-2	Main Case Assembly G-1
			S A E	Assembly No. E-2	Rel. Code Pages 20-21			
Model 5952-E								
301364 (Cont'd)								
-54	Ford	Push Type	—	—	—	59-35-11	47-19-73-1X	59-15-5-2X
-55	Ford	Push Type	—	—	—	59-35-11	47-19-73-1X	59-15-5-2X
-56	Ford	Push Type	2	47-518-5	—	59-35-17	47-19-74-1X	59-15-1-2X
-57	Ford	Push Type	2	47-518-5	—	59-35-17	47-19-74-1X	59-15-1-2X
-58	Ford	Push Type	2	47-518-5	—	59-35-17	47-19-74-1X	59-15-1-2X
-59	Vermeer Mfg.	Push Type	2	46-518-22-1X	26	59-35-1	47-19-82-1X	59-15-12-4X
-60	Never released for production							
-61	Never released for production							
-62	Never released for production							
-63	Never released for production							
-64	Never released for production							
-65	Ford	Pull Type	2	47-518-4-1X	—	59-35-14	53-19-11-1X	59-15-1-2X
-66	Ford	Pull Type	2	47-518-4-1X	—	59-35-14	53-19-11-1X	59-15-1-2X
-67	Ford	Pull Type	2	47-518-4-1X	—	59-35-14	53-19-11-1X	59-15-1-2X
-68	Never released for production							
-69	Never released for production							
-70	Never released for production							
-71	Service	Pull Type	2	46-518-22-1X	8	59-35-1	53-19-11-1X	59-15-3-2X
-72	Volvo-GM	Pull Type	2	47-518-4-1X	—	59-35-14	53-19-11-1X	59-15-3-2X
-73	Volvo-GM	Pull Type	2	47-518-4-1X	—	59-35-14	53-19-11-1X	59-15-3-2X
-74	Rolligon Corp.	Pull Type	2	47-518-4-1X	62	59-35-14	53-19-11-1X	59-15-7-2X
-75	Spicer France	Push Type	—	—	—	59-35-1	47-19-78-1X	59-15-7-2X
-76	Never released for production							
-77	Never released for production							
-78	Never released for production							
-79	Never released for production							
-80	Never released for production							
-81	Never released for production							
-82	Never released for production							
-83	T.S.P.	Push Type	2	312830X	56	59-35-1	47-19-78-1X	59-15-9-2X
-84	Ford	Push Type	—	—	—	59-35-11	47-19-73-1X	59-15-5-2X
-85	Ford	Push Type	—	—	—	59-35-11	47-19-73-1X	59-15-5-2X
-86	Ford	Push Type	2	47-518-5	—	59-35-17	47-19-74-1X	59-15-1-2X
-87	Ford	Push Type	2	47-518-5	—	59-35-17	47-19-74-1X	59-15-1-2X
-88	Ford	Pull Type	2	47-518-4-1X	—	59-35-14	53-19-11-1X	59-15-1-2X
-89	Spicer France	Push Type	—	—	—	59-35-1	47-19-78-1X	59-15-7-2X
-90	Spicer France	Push Type	—	—	—	59-35-1	47-19-78-1X	59-15-7-2X

PARTS LISTED IN THIS CATALOG MAY NO LONGER BE AVAILABLE, USE WITH TRANSMISSION SUPERSEDING LIST.

MODEL CM59

TABULATED BILLS OF MATERIAL

T210-ES60-5

Tab No.	Rear Bearing Cap Assembly Cap, Seal and Bushing H-1	SPEEDOMETER		End Yoke or Companion Flange B-22	SHIFTER		
		Drive Gear B-21	Driven Gear H-8		Housing Ass'y Pages 14-15	Lever & Dome Ass'y Page 19	Remote Control Pages 16-18
Model 5952-E							
301364							
-54	53-19-15-2X	—	—	—	47-16-1-8X	—	—
-55	53-19-17-2X	—	—	—	47-16-1-8X	—	—
-56	53-19-13-2X	—	—	—	47-16-1-8X	—	—
-57	53-19-15-2X	—	—	—	47-16-1-8X	—	—
-58	53-19-17-2X	—	—	—	47-16-1-8X	—	—
-59	53-19-12-4X	—	—	—	47-16-1-8X	—	—
-60	Never released for production						
-61	Never released for production						
-62	Never released for production						
-63	Never released for production						
-64	Never released for production						
-65	53-19-13-2X	—	—	—	47-16-1-8X	—	—
-66	53-19-15-2X	—	—	—	47-16-1-8X	—	—
-67	53-19-17-2X	—	—	—	47-16-1-8X	—	—
-68	Never released for production						
-69	Never released for production						
-70	Never released for production						
-71	53-19-12-4X	—	—	—	47-16-1-8X	47-16-3-1X	—
-72	53-19-7-4X	53-452-3	—	—	47-16-1-8X	—	—
-73	53-19-12-4X	53-452-3	—	—	47-16-1-8X	—	—
-74	53-19-3-4X	53-452-2	—	53-106-2	47-16-1-8X	47-16-5-21X	—
-75	53-19-7-4X	53-452-4	53-453-2	—	47-16-1-11X	—	—
-76	Never released for production						
-77	Never released for production						
-78	Never released for production						
-79	Never released for production						
-80	Never released for production						
-81	Never released for production						
-82	Never released for production						
-83	53-19-12-4X	53-452-3	62-453-4	53-106-2	47-16-1-11X	—	—
-84	53-19-22-1X	53-452-6	—	4-4-4611-2	47-16-1-8X	—	—
-85	53-19-22-1X	53-452-6	—	5-4-6481-1	47-16-1-8X	—	—
-86	53-19-22-1X	53-452-6	—	4-4-4611-2	47-16-1-8X	—	—
-87	53-19-22-1X	53-452-6	—	5-4-6481-1	47-16-1-8X	—	—
-88	53-19-22-1X	53-452-6	—	5-4-6481-1	47-16-1-8X	—	—
-89	53-19-12-4X	53-452-4	53-453-2	4-4-4491	47-16-1-11X	—	—
-90	53-19-12-4X	53-452'4	53-453-2	4-4-4491	47-16-1-8X	47-16-5-43X	—

For parts or service call us
Pro Gear & Transmission, Inc.



1 (877) 776-4600

(407) 872-1901

parts@eprogear.com

906 W. Gore St.

Orlando, FL 32805

