

# **SPICER®**

WEATHERLY INDEX 084

**T210-CM60**

May 1990

**Supersedes T210-CM60**

Dated April 1980

**CM60 Series**

**Main Transmission**

**Parts List**

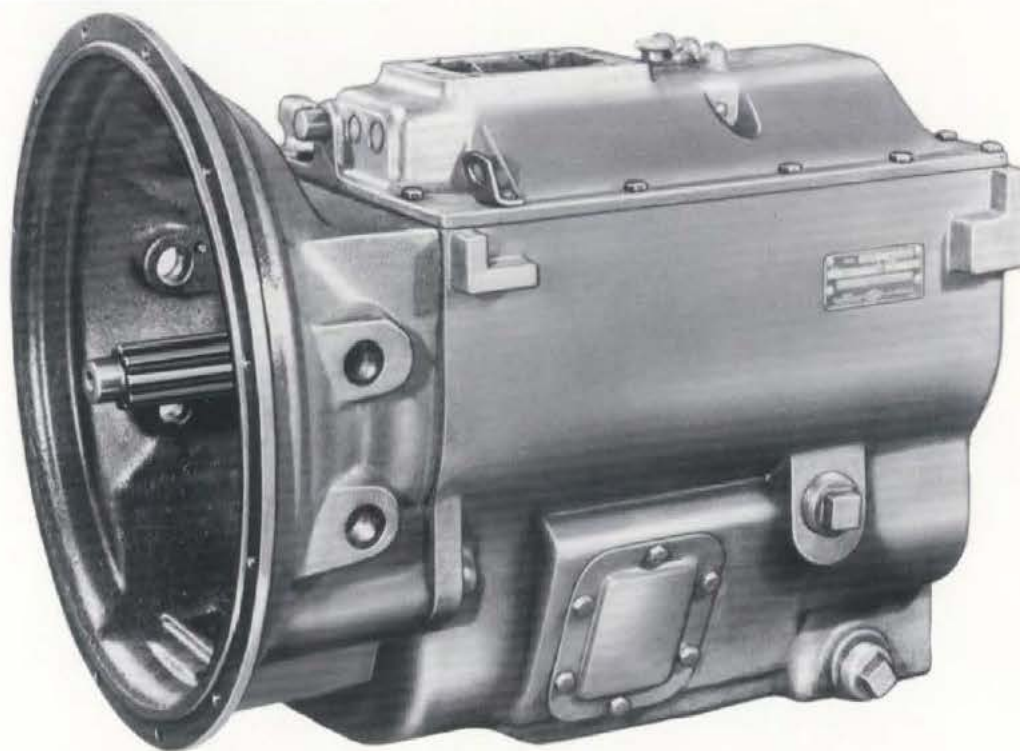

## **CM60 Series Main Transmission**

For parts or service call us  
Pro Gear & Transmission, Inc.



**1 (877) 776-4600**

**(407) 872-1901**

**parts@eprogear.com**

**906 W. Gore St.**

**Orlando, FL 32805**





# MODEL CM60

## RATIO TABLE and IDENTIFICATION

T210-CM60

### CONTENTS

RATIO TABLE and IDENTIFICATION .....	1
GEARS and RELATED PARTS .....	2-5
DRIVE GEAR GROUP .....	2
MAINSHAFT GROUP .....	2-3
COUNTERSHAFT GROUP .....	4-5
REVERSE IDLER GROUP .....	4-5
DRIVE GEAR TABLE .....	6
MAINSHAFT REAR BEARING CAP CHART .....	7
DRIVE GEAR BEARING CAP CHART .....	7
CASE, GROUP and RELATED PARTS .....	8-10
DRIVE GEAR BEARING CAP GROUP .....	8-9
CLUTCH HOUSING GROUP .....	8-9
CASE GROUP .....	8-9
MAINSHAFT REAR BEARING CAP GROUP .....	10
COUNTERSHAFT REAR BEARING CAP GROUP .....	10
CLUTCH HOUSING DIMENSIONS .....	11
SHIFTER HOUSING ASSEMBLY .....	12-13
REMOTE CONTROL ASSEMBLY .....	14-15
COMPANION FLANGE and END YOKES .....	16
SHIFT LEVER and DOME ASSEMBLY .....	17
CLUTCH RELEASE and TABLE .....	18-19
OVERHAUL KITS—MAJOR and MINOR .....	20-21
SUPERSESSON and REPLACEMENT LIST—CM60 to ES65-5 .....	22-25
TABULATED BILLS of MATERIAL .....	26-71

### RATIO TABLE

MODEL CM60 and CM62 SERIES							
SPEEDS	MODELS						
	6052-A	6052-B	6052-C	6052-D	6252-B	6253-A	6253-B
1st	7.28	7.28	6.68	7.28	5.06	5.70	5.06
2nd	4.09	4.38	3.52	4.09	3.05	3.00	3.05
3rd	2.41	2.71	1.97	2.28	1.78	1.78	1.78
4th	1.44	1.61	1.17	1.28	1.33	1.00	1.00
5th	1.00	1.00	1.00	1.00	1.00	.85	.69
Rev.	7.28	7.28	6.68	7.28	5.06	5.70	5.06

#### IDENTIFICATION

The Name Plate (NP-96) affixed to the LEFT side of the Transmission is stamped with information:

SERIAL

B/M No.  MODEL

In requesting more information on these transmissions, furnish the B/M No. and the Serial Number.

Abbreviations used in this parts list include:

- N.S. — Not Shown
- N.S.S. — Not Sold Separately
- N.R. — Not Required
- A.R. — As Required

# MODEL CM60

## GEARS and RELATED PARTS

**SPICER®**



T210-CM60

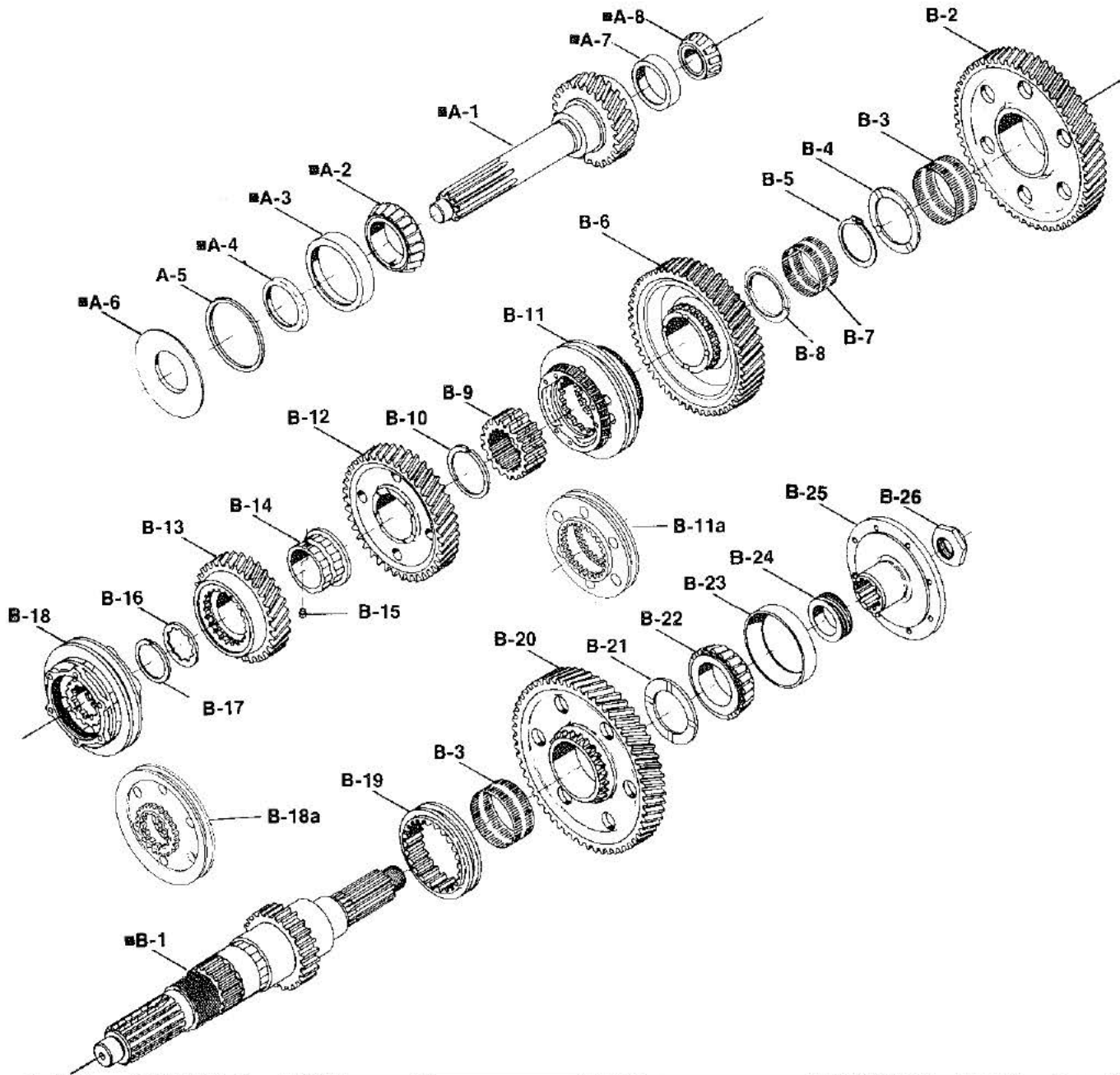

Ref. No.	Part Number	Part Description	Qty.
<b>Drive Gear Group—Input</b>			
A-1 ■	See Tab Bills	Gear—Main Drive (see Drive Gear Table Page) . . . . .	1
A-2 ■	550930	Cone—Main Drive Gear Bearing . . . . .	1
A-3 ■	550929	Cup—Main Drive Gear Bearing . . . . .	1
N.S.	313240-3X	Baffle and Shim Kit . . . . .	1
A-4 ■	47-468-2*	Baffle—Oil Ring Drive Gear . . . . .	1
A-5	47-228-2-2*	Spacer/Shim . . . . .	1
A-6 ■	47-468-1*	Baffle—Bearing Cap . . . . .	1
A-7 ■	550228	Cup Bearing—Drive Gear Pocket . . . . .	1
A-8 ■	550183	Cone Bearing—Drive Gear Pocket . . . . .	1

\* Included in 313240-3X Kit.

■ Use 313240-3X Baffle and Shim Kit when any of these parts are replaced, since the end play will be affected. Recommended end play is .003" / .008".  
 N.S.—Not Shown

PARTS LISTED IN THIS CATALOG MAY NO LONGER BE AVAILABLE, USE WITH TRANSMISSION SUPERSEDING LIST.



# MODEL CM60

## GEARS and RELATED PARTS

T210-CM60

Ref. No.	Part Number	Part Description	Qty.
<b>Mainshaft Group—Output</b>			
B-1 ■	63-362-4	Mainshaft (overall length 22 9/32") Before S/N—27999647	1
or	63-362-3	Mainshaft (overall length 22 13/32") (Ford) Before S/N—2799647	1
or	63-362-5	Mainshaft (overall length 22 9/32") Starting & After S/N—2799647	1
or	63-362-6	Mainshaft (overall length 22 13/32") (Ford) Starting & After S/N—2799647	1
B-2	63-8-1	Gear—1st Speed (57T)	1
or	63-8-23	Gear—1st Speed (57T) Special Back Tapered Clutch Teeth	1
B-3	550938	Bearing—1st and Rev. Gear Needle Assy.	2
B-4	330884	Thrust Washer—1st and 2nd Gear	1
B-5	63-381-1	Snap Ring	1
B-6	63-8-4	Gear—2nd Speed (47T) 6052A, 6052D Before S/N—2799647	1
or	63-8-15	Gear—2nd Speed (48T) 6052B,6252B,6352B Before S/N—2799647	1
or	63-8-16	Gear—2nd Speed (46T) 6052C,6253A Before S/N—2799647	1
or	63-8-24	Gear—2nd Speed (47T) 6052A,6052D Starting & After S/N—2799647	1
or	63-8-26	Gear—2nd Speed (48T) 6052B,6252B,6253B Starting & After S/N—2799647	1
or	63-8-25	Gear—2nd Speed (46T) 6052C,6253A Starting & After S/N—2799647	1
B-7	550983	Bearing—Split Needle 2nd Speed Gear Starting and After S/N—2799647	1
B-8	63-47-1	Thrust Washer—Split Needle Bearing Starting & After S/N—2799647	1
B-9	62-466-14	Clutch Gear—2nd and 3rd	1
B-10	62-381-8	Snap Ring	1
B-11	310227X	Synchronizer—2nd and 3rd	1
or	310795X	Synchronizer—2nd and 3rd (Special) (Not Synchronized on 2nd)	1
B-11a	62-466-17	Clutch Collar (used in units with no Synchronizers)	1
B-12	63-8-21	Gear—3rd Speed (40T) 6252B,6253B	1
or	62-8-40	Gear—3rd Speed (39T) 6052A	1
or	62-8-43	Gear—3rd Speed (37T) 6052C	1
or	62-8-66	Gear—3rd Speed (38T) 6052D,6253A	1
or	62-8-82	Gear—3rd Speed (41T) 6052B	1
B-13	62-8-42	Gear—4th Speed (30T) 6052A	1
or	62-8-49	Gear—4th Speed (24T) 6253B	1
or	62-8-50	Gear—4th Speed (32T) 6052B	1
or	62-8-51	Gear—4th Speed (35T) 6252B	1
or	62-8-68	Gear—4th Speed (25T) 6253A	1
or	62-8-78	Gear—4th Speed (28T) 6052C,6052D	1
B-14	62-37-29	Spacer—Sleeve 4th Gear	1
B-15	425-SP	Pin—Spacer Sleeve	1
B-16	1001-W	Thrust Washer—4th Gear	1
B-17	62-381-4	Snap Ring—4th Speed Thrust Washer	1
B-18	312766X	Synchronizer—4th & 5th 6052A,6052B,6052C,6052D,6253B	1
or	313007X	Synchronizer—4th & 5th 6252B,6253A	1
B-18a	62-466-23	Clutch Collar—4th & 5th (used in units with no Synchronizers)	1
B-19	63-465-4	Clutch Collar—1st and Reverse	1
or	63-465-3	Clutch Collar—1st & Rev. (used in units with Back Tapered Clutch teeth)	1
B-20	63-8-3	Gear—Reverse (57T)	1
or	63-8-22	Gear—Reverse (57T) Special with Back Tapered Clutch Teeth	1
B-21	330871	Thrust Washer	1
B-22	550612	Cone—Mainshaft Rear	1
B-23	550929	Cup—Mainshaft Rear	1
B-24	See Tab Bills	Speedometer Drive Gear	1
or	62-37-22	Spacer—used in place of Speedometer Drive Gear	1
B-25	See Tab Bills	Flange or Yoke—U-Joint	1
B-26	500898	Nut—1 1/4"-18 Hex Head Self-locking	1

■ Use 313240-3X Baffle and Shim Kit when any of these parts are replaced, since the end play will be affected. Recommended end play is .003"/.008".

# MODEL CM60

GEARS and RELATED PARTS

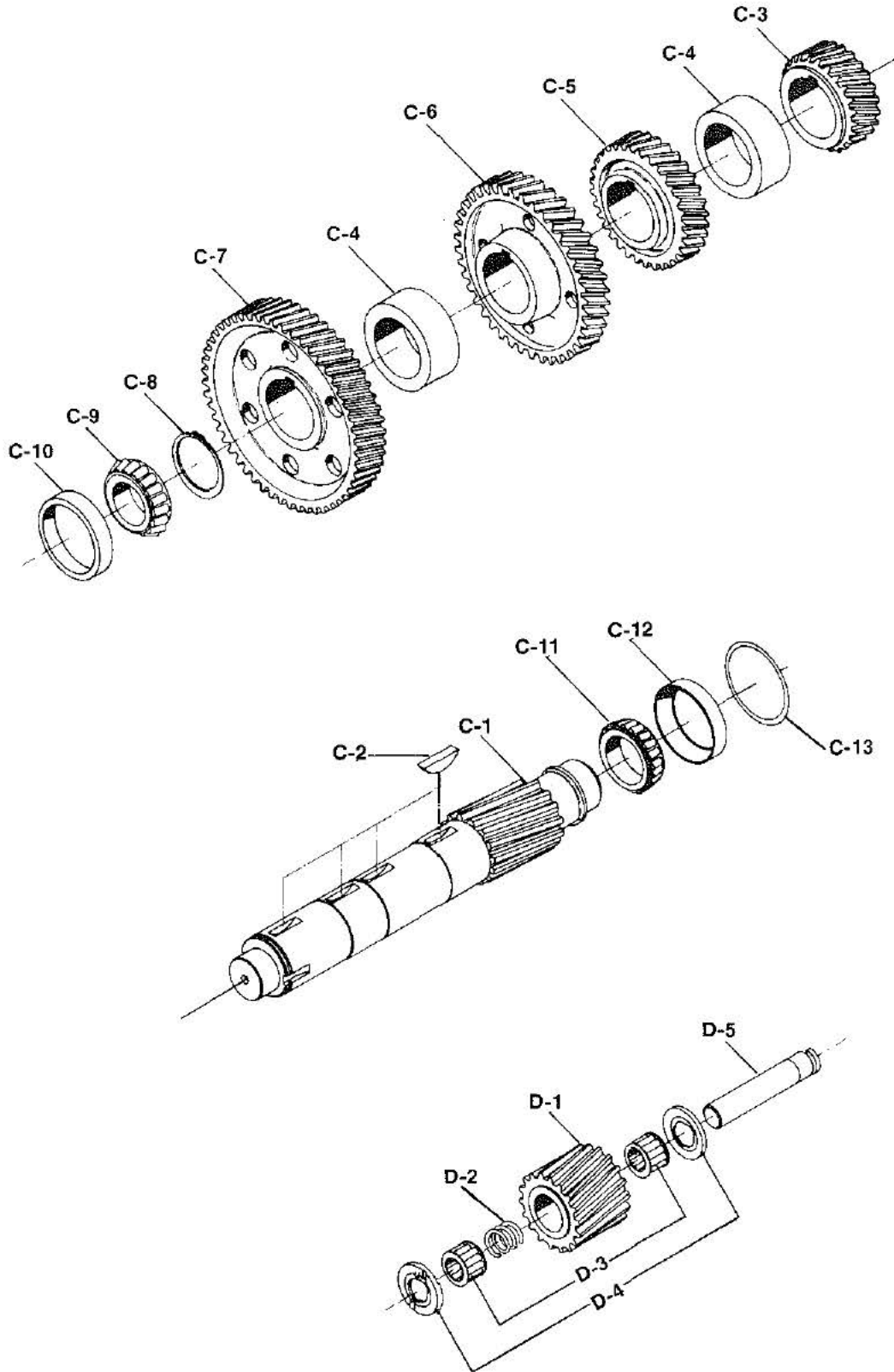

PARTS LISTED IN THIS CATALOG MAY NO LONGER BE AVAILABLE, USE WITH TRANSMISSION SUPERSEDING LIST.



# MODEL CM60

## GEARS and RELATED PARTS

T210-CM60

Ref. No.	Part Number	Part Description	Qty.
<b>Countershaft Group</b>			
C-1	63-30-1	Countershaft (15T) .....	1
C-2	500010-8	Woodruff Key .....	4
C-3	63-196-1	Gear—2nd Speed (22T) 6052A,6052D .....	1
or	63-196-14	Gear—2nd Speed (21T) 6052B,6252B,6253B .....	1
or	63-196-16	Gear—2nd Speed (23T) 6052C,6253A .....	1
C-4	63-37-1	Spacer—2nd, 3rd, 4th and 5th Speeds .....	2
C-5	55-196-33	Gear—3rd Speed (31T) 6052A .....	1
or	62-196-54	Gear—3rd Speed (29T) 6052B .....	1
or	62-196-31	Gear—3rd Speed (33T) 6052C .....	1
or	62-196-43	Gear—3rd Speed (32T) 6253A,6052D .....	1
or	62-196-35	Gear—3rd Speed (30T) 6252B,6253B .....	1
C-6	62-196-29	Gear—4th Speed (40T) 6052A .....	1
or	62-196-15	Gear—4th Speed (38T) 6052B .....	1
or	62-196-52	Gear—4th Speed (42T) 6052C,6052D .....	1
or	63-196-18	Gear—4th Speed (46T) 6253B .....	1
or	63-196-19	Gear—4th Speed (44T) 6253A .....	1
or	63-196-24	Gear—4th Speed (35T) 6252B .....	1
C-7	63-1-1	Gear—Countershaft Drive (46T) 6052A,6052B,6052D .....	1
or	63-1-3	Gear—Countershaft Drive (44T) 6052C .....	1
or	63-1-4	Gear—Countershaft Drive (42T) 6253A .....	1
or	63-1-6	Gear—Countershaft Drive (40T) 6253B .....	1
C-8	70-381-6	Snap Ring—Countershaft Drive Gear .....	1
C-9	550934	Cone—Front Bearing .....	1
C-10	550933	Cup—Front Bearing .....	1
C-11	550936	Cone—Taper Rear Bearing .....	1
C-12	550935	Cup—Taper Rear Bearing .....	1
C-13	313439X	Shim Kit to Adjust Countershaft End Play .....	1
<b>Reverse Idler Group</b>			
D-1	63-5-1	Gear—Reverse Idler .....	1
D-2	97-37-1	Bearing Spacer .....	1
D-3	550886	Bearing—Roller Assy. ....	2
D-4	974-W	Thrust Washer .....	2
D-5	63-60-1	Shaft—Reverse Idler .....	1

Listed below are Service Kits used to upgrade any CM-60 Transmission built before Serial No. 2799647. Kits include (1) 550983 Split Needle Bearing, (1) 63-47-1 Split Thrust Washer, (1) 2812 Bulletin and (1) each 2nd Speed Mainshaft Gear and Mainshaft as shown for the respective Models. These Kits are not included in the Overhaul Kits.

313597X	CM6052-A & D	63-8-24 2nd Gear, 63-362-5 Mainshaft	1
313598X	CM6052-A & D (Ford M/S)	63-8-24 2nd Gear, 63-362-6 Mainshaft	1
313599X	CM6052-C	63-8-25 2nd Gear, 63-362-5 Mainshaft	1
313602X	CM6052-C (Ford M/S)	63-8-25 2nd Gear, 63-362-6 Mainshaft	1
313603X	CM6052-B, 6252-B, 6253-B	63-8-26 2nd Gear, 63-362-5 Mainshaft	1
313604X	CM6052-B, 6252-B, 6253-B (Ford M/S)	63-8-26 2nd Gear, 63-362-6 Mainshaft	1

# MODEL CM60 DRIVE GEAR TABLE

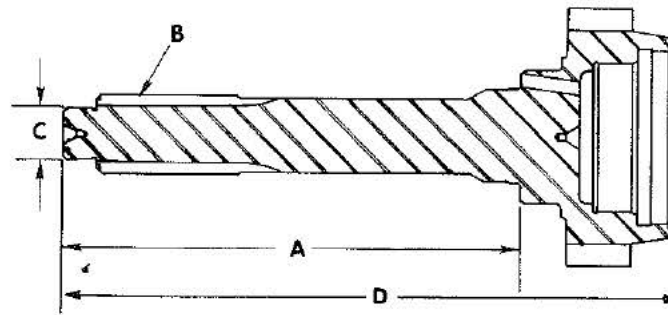

Teeth	"D" Overall Length	A Length	B Spline Dia. Teeth	C-Pilot	Drive Gear Part No.	Old Superseded Part No.
				Size		
24	12 15/32"	9.425"	1 1/2"-10	.983"	63-35-48-1X*	63-35-14
24	13 13/32"	10.362"	1 1/2"-10	.983"	63-35-37-1X*	63-35-15
24	11 31/32"	8.925"	1 1/2"-10	.983"	63-35-45-1X*	63-35-3
24	12 15/16"	9.896"	1 1/2"-10	.983"	63-35-38-1X*	63-35-18
24	12 15/16"	9.896"	1 3/4"-10	1.180"	63-35-47-1X*	63-35-13
24	11 31/32"	8.925"	1 3/4"-10	.983"	63-35-53-1X*	63-35-30
24	13 13/32"	10.362"	1 3/4"-10	1.180"	63-35-34-1X*	63-35-1
24	13 13/32"	10.362"	1 3/4"-10	.983"	63-35-57-1X*	63-35-55
25	12 15/32"	9.425"	1 1/2"-10	.983"	63-35-49-1X*	63-35-21
25	13 13/32"	10.362"	1 1/2"-10	.983"	63-35-39-1X*	63-35-23
25	12 15/16"	9.896"	1 1/2"-10	.983"	63-35-40-1X*	63-35-24
25	12 15/16"	9.896"	1 3/4"-10	1.180"	63-35-52-1X*	63-35-29
25	13 13/32"	10.362"	1 3/4"-10	1.180"	63-35-46-1X*	63-35-8
25	13 13/32"	10.362"	1 3/4"-10	.983"	63-35-56-1X*	63-35-54
28	12 15/16"	9.896"	1 3/4"-10	1.180"	63-35-50-1X*	63-35-25
28	13 13/32"	10.362"	1 3/4"-10	1.180"	63-35-35-1X*	63-35-10
30	13 13/32"	10.362"	1 3/4"-10	1.180"	63-35-36-1X*	63-35-12

\* Includes Drive Gear and 313240-3X Baffle & Shim Kit.

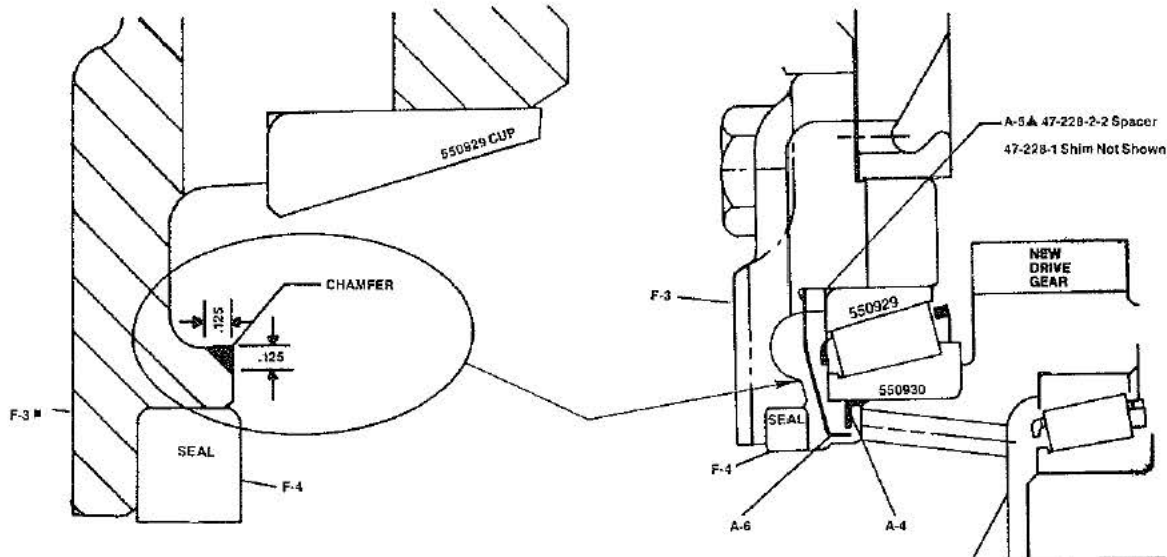

■ NOTE: old bearing caps have to be modified, when used with NEW DRIVE GEAR as shown in illustration above.  
 ▲ Use 313240-3X Spacer / Shim Kit, recommended end play is .003" / .008".

PARTS LISTED IN THIS CATALOG MAY NO LONGER BE AVAILABLE, USE WITH TRANSMISSION SUPERSEDING LIST.





# MODEL CM60

## REAR BEARING CAP and DRIVE GEAR BEARING CAP CHARTS

T210-CM60

### REAR BEARING CAP CHART

BEARING CAP ASSEMBLY INCLUDES See page 10 for items H-4, H-5, H-3, H-6

Service Part Number	Oil Seal H-4	Casting Number	Speedometer Bushing H-5	Page 10 Gasket H-3	Screws H-6	Qty.	Brake Type
63-19-6-2X	60-463-8	C63-19-7	60-475-1	63-223-3	545001-1	(4)	—
63-19-8-2X	60-463-8	C63-19-9	30-475-1	63-223-6	{ 545001-1 545008-1	(4) (2)	DCM
63-19-10-2X	60-463-8	C63-19-4	30-475-1	63-223-3	545001-1	(4)	—
63-19-27-2X	60-463-8	C63-19-7	60-475-1	63-223-3	{ 545001-1 545001-7	(3) (1)	—
63-19-33-2X	63-463-1	C63-19-35	—	63-223-7	545001-1	(6)	12" x 4"
63-19-37-2X	71-463-12	C63-19-29	60-475-1	63-223-6	{ 545001-1 545008-1 545008	(4) (1) (1)	—
63-19-38-2X } BSSN2816795 }	63-463-1	C63-19-39	—	63-223-7	545001-1	(6)	—
63-19-38-1X } ASSN2216795 }	63-463-1	C63-19-39	—	63-223-7	545001-1	(6)	—
63-19-40-2X	60-463-8	C63-19-41	—	63-223-3	{ 545001-1 545008-1	(4) (2)	DCM
63-19-42-2X	60-463-8	C63-19-43	—	63-223-6	545001-1	(4)	—

### FRONT BEARING CAP

Old	New
63-19-1-1X	63-19-36-1X
63-19-19-1X	63-19-36-1X
63-19-4-1X	63-19-22-1X
63-19-12-1X	63-19-20-1X
63-19-15-1X	63-19-21-1X
63-19-17-2-1X	63-19-30-2-1X
63-19-17-3-1X	63-19-30-3-1X
63-19-23-1X	63-19-31-1X

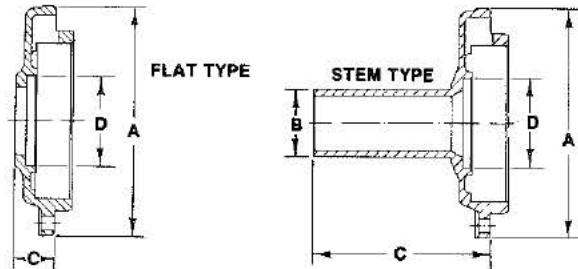

NOTE: old bearing caps have to be modified, when used with NEW DRIVE GEAR as shown in illustration page 6.

### FRONT BEARING CAP CHART

A Outside Diameter	B Stem Diameter	C Length	D Oil Seal Bore Diameter	FRONT BEARING CAP	
				Casting Number	Assembly Includes Oil Seal F-2
<b>FLAT TYPE</b>				<b>PULL TYPE RELEASE</b>	
7 5/8"	—	15/16"	2 1/2"	C63-19-2-1	63-19-36-1X
<b>STEM TYPE</b>				<b>PUSH TYPE RELEASE</b>	
7 7/32"	1 15/16"	6 7/32"	2 1/2"	C63-19-13	63-19-20-1X
7 5/8"	1 15/16"	6 7/32"	2 1/2"	C63-19-16	63-19-21-1X
7 5/8"	1 7/8"	5 29/32"	2 1/2"	C63-19-5	63-19-22-1X
7 5/8"	2 1/4"	5 27/32"	2 1/2"	C63-19-18	63-19-30-2-1X
7 5/8"	2 1/4"	6 13/32"	2 1/2"	C63-19-18	63-19-30-3-1X
7 5/8"	1 7/8"	5 3/8"	2 1/2"	C63-19-5	63-19-31-1X

PARTS LISTED IN THIS CATALOG MAY NO LONGER BE AVAILABLE, USE WITH TRANSMISSION SUPERSEDING LIST.

# MODEL CM60

SPICER®



T210-CM60

CASE GROUP and RELATED PARTS

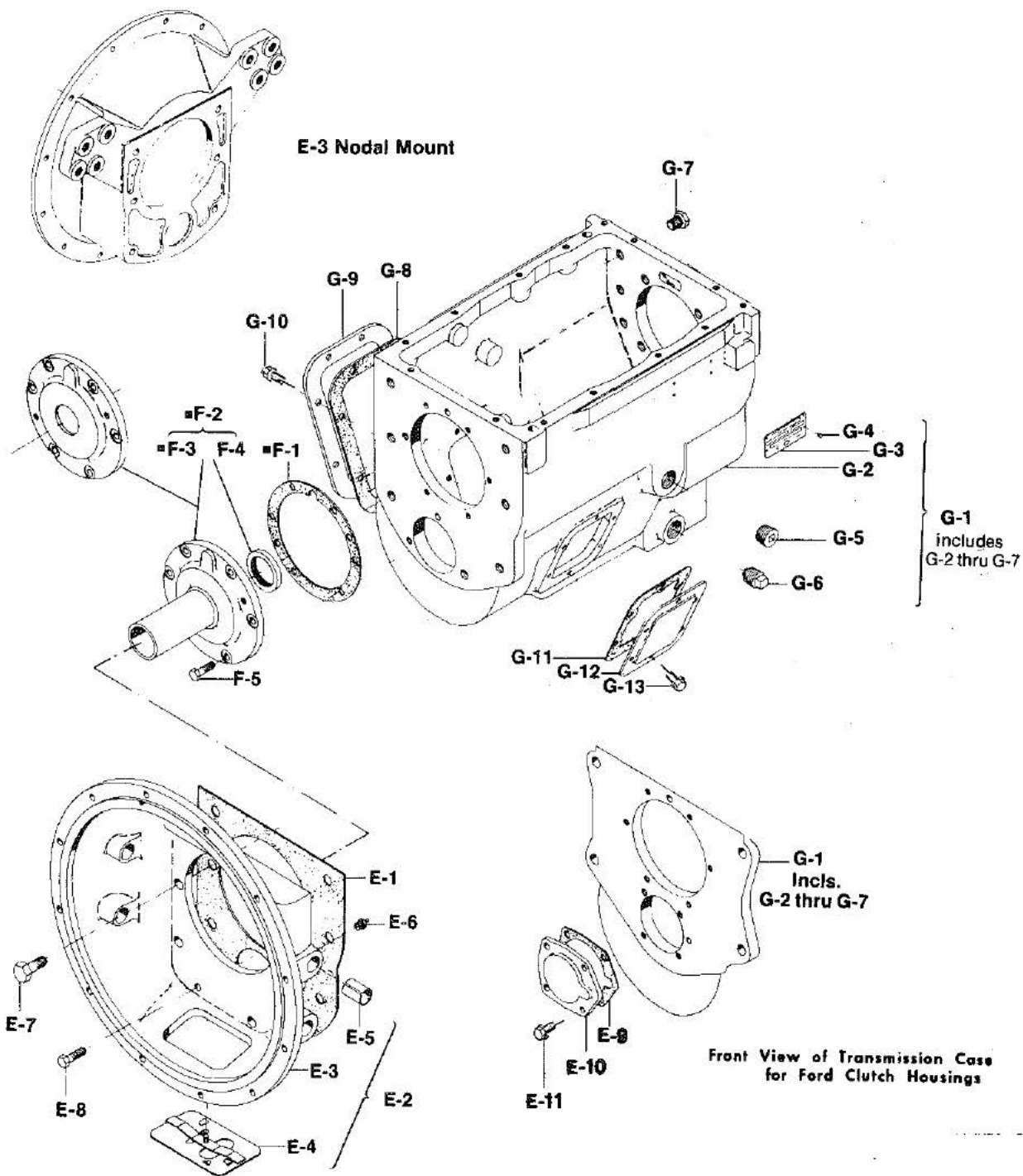

■ Use 313420-3X Baffle and Shim Kit when any of these parts are replaced since the end play will be affected. The recommended end play is .003"/.008".

PARTS LISTED IN THIS CATALOG MAY NO LONGER BE AVAILABLE, USE WITH TRANSMISSION SUPERSEDING LIST.



Ref. No.	Part Number	Part Description	Qty.
<b>Drive Gear Bearing Cap Group</b>			
F-1 ■	63-223-2	Gasket	1
or	63-223-4	Gasket (Ford)	1
F-2 ■	See Tab Bills	Bearing Cap and Oil Seal Assy. (includes F-3 & F-4)	1
F-3 ■	N.S.S.	Bearing Cap	1
F-4 ■	60-463-10-1X	Oil Seal (includes installation sleeves)	1
F-5	545002-4	Bolt—3/8"-16 x 1 1/8" Hex Head Self-locking	6
<b>Clutch Housing Group</b>			
E-1	63-352-2	Gasket—Clutch Housing	1
E-2	See Tab Bills	Clutch Housing Assy. (includes E-3 thru E-5)	1
E-3	N.S.S.	Clutch Housing (see Clutch Housing table Page)	1
E-4	46-96-2-1X	Hand Hole Cover Assy.	1
E-5	128C-20	Bushing—Clutch Release	4
E-6	500169-5	Zerk Fitting—Grease	2
E-7	545008	Bolt—5/8"-11 x 1 1/4" Hex Head Self-locking	7
or	545008-3	Bolt—5/8"-11 x 1 3/4" Hex Head Self-locking (Ford Case Dana front)	7
E-8	545028	Bolt—7/16"-14 x 1 1/4" Hex Head Self-locking	1
or	545028-1	Bolt—7/16"-14 x 1 5/8" Hex Head Self-locking (Ford Case Dana front)	1
<b>Countershaft Front Bearing Cap (Ford Case with Apron Front)</b>			
E-9	63-223-5	Gasket	1
E-10	63-22-2	Bearing Cap	1
E-11	330800	Bolt—3/8"-16 x 3/4" Hex Head Self-locking	4
<b>Case Group</b>			
G-1	See Tab Bills	Case Assembly—(Includes G-2 thru G-7)	1
G-2	N.S.S.	Case (C63-15-2-1 63-15-1-1X)(C63-15-12 63-15-11-1X) (C63-15-6-1 63-15-15-1X)	1
G-3	NP-96	Nameplate	1
G-4	252-SP	Pins—Nameplate	4
N.S.	NP-196	Patent Plate	1
G-5	500100	Plug—Filler	1
G-6	62-39-3	Drain Plug—Magnetic Square Head (63-15-1-1X)	1
or	62-39-4	Drain Plug—Magnetic Recessed Head (63-15-11-1X 63-15-15-1X)	1
G-7	266-D	Plug—5/8"-11 x 7/16" Hex Head	3or5
G-8	97-324-2	Gasket—PTO Aperture (8 bolt)	1
G-9	73-267-1	Cover—PTO Aperture (8 bolt)	1
G-10	545012	Bolt—7/16"-14 x 3/4" Flanged Hex Head Self-locking	8
G-11	97-324-1	Gasket—PTO Aperture (6 bolt)	1
G-12	50-267-2	Cover—PTO Aperture (6 bolt)	1
G-13	330800	Bolt—3/8"-16 x 3/4" Hex Head Self-locking	6

■ Use 313240-3X Baffle and Shim Kit when any of these parts are replaced, since the end play will be affected. Recommended end play is .003"/.008".  
 N.S.S.—Not Sold Separately.  
 N.S.—Not Shown

# MODEL CM60

SPICER®



T210-CM60

REAR, BEARING CAP GROUP and RELATED PARTS

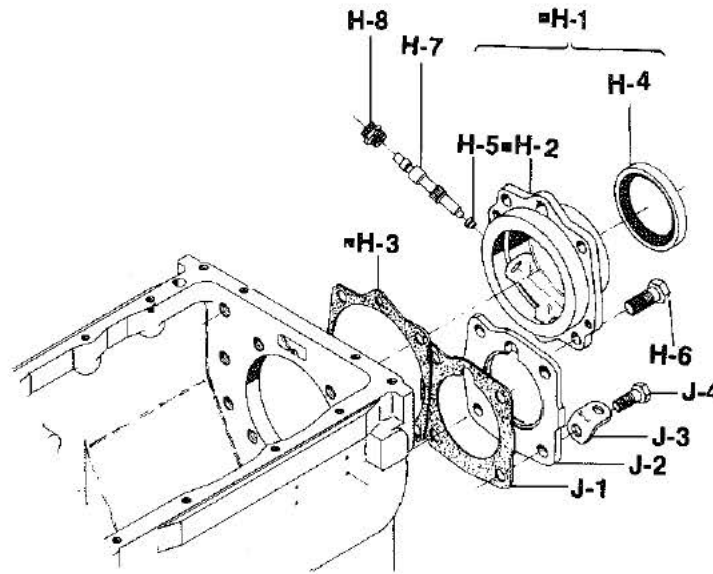

Ref. No.	Part Number	Part Description	Qty.
<b>Mainshaft Rear Bearing Cap Group</b>			
H-1 ■	See Tab Bills	Cap Assy.—Rear Bearing .....	1
H-2 ■	N.S.S.	Cap—Rear Bearing (See table page 7) .....	1
H-3 ■	63-223-3	Gasket .....	1
or	63-223-6	Gasket—(used with Brake mounting) .....	1
or	63-223-7	Gasket—(for Electronic Speedo Cap for Ford) .....	1
H-4	63-463-1	Oil Seal—(Ford only) .....	1
or	60-463-8	Oil Seal—(3.756" O.D.) .....	1
or	71-463-12	Oil Seal—(3.543" O.D.) .....	1
H-5	60-475-1	Bushing—Speedometer (5/16" I.D. Flanged) .....	1
or	30-475-1	Bushing—Speedometer (1/4" I.D.) .....	1
H-6	545001-1	Bolt—1/2"-13 × 1 3/8" (See Bearing Cap table for Qty.) .....	A/R
	545001-7	Bolt—1/2"-13 × 1 7/8" (See Bearing Cap table for Qty.) .....	A/R
	545008	Bolt—5/8"-11 × 1 1/4" (See Bearing Cap table for Qty.) .....	A/R
	545008-1	Bolt—5/8"-11 × 1 1/2" (See Bearing Cap table for Qty.) .....	A/R
or	330180-10	Stud—1/2"-20 × 2 1/8" (used with Ford Bearing Cap) .....	6
and	500371-5	Nut—1/2"-20 Hex (used with Ford Bearing Cap) .....	4
H-7	See Tab Bills	Gear—Speedometer Driven .....	1
or	55-334-1	Plug—(used when there is no Speedometer Driven Gear) .....	1
N.S.	545106	Plug—Speedometer Outlet (Ford only) .....	1
or	545021	Plug—Electronic Sensor Hole .....	1
H-8	55-451-1	Sleeve—1 1/4" long—Speedometer Driven Gear .....	1
or	44-473-1	Sleeve—5" long—Speedometer Driven Gear .....	1
or	97-454-2-1X	Sleeve—1 1/4" long—Speedometer Driven Gear (with Seal) .....	1
<b>Countershaft Rear Bearing Cap Group</b>			
J-1	63-223-1	Gasket .....	1
J-2	63-22-1	Cap—Bearing .....	1
J-3	330564-3	Hook—Lift .....	1
J-4	545001	Bolt—1/2"-13 × 1 1/2" Hex Head Self-locking .....	4

N.S.—Not Shown

N.S.S.—Not Sold Separately

■ Use 313240-3X Baffle and Shim Kit when any of these parts are replaced, since the end play will be affected. Recommended end play is .003"/.008".

A/R—As Required

PARTS LISTED IN THIS CATALOG MAY NO LONGER BE AVAILABLE, USE WITH TRANSMISSION SUPERSEDING LIST.

SAE		
Size No.	A Pilot Dia.	B O.D.
1	20 $\frac{1}{8}$ "	21 $\frac{3}{4}$ "
2	17 $\frac{5}{8}$ "	19 $\frac{1}{4}$ "
3	16 $\frac{1}{8}$ "	17 $\frac{3}{4}$ "

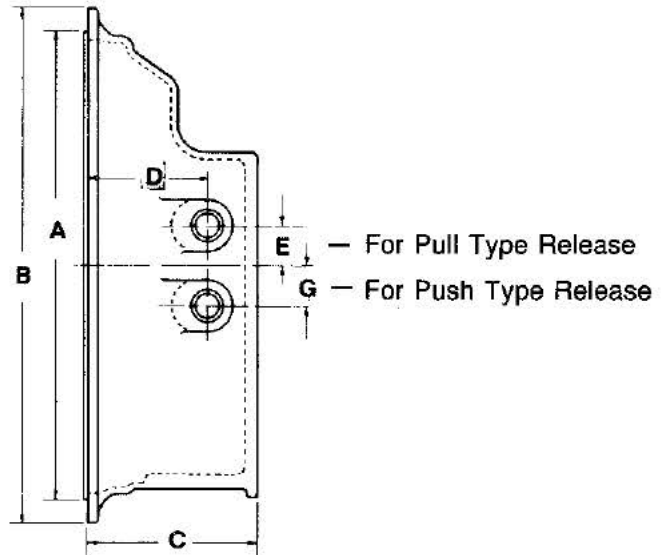

CLUTCH HOUSING				RELEASE SHAFT HOLE				
Service Assembly No.	Bushing Number	Casting Part Number	S A E	C Length	C/L Dia.	D E Front Face	G Above C/L	Below C/L
312098X ◀	128C-20	C62-518-25	2	6"	1"	35/8"	—	21/2"
62-518-27-1X	128C-20	C102C-430-3	2	5 1/16"	1"	3" 2 17/32"	1 1/2" —	— 25/8"
62-518-29-1X	128C-20	C62-518-13	2	6 1/2"	1"	33/4" 35/8"	1 1/2" —	— 21/2"
62-518-30-1X	128C-20	C62-518-13	2	6 1/2"	1"	43/16" 35/8"	1 1/2" —	— 21/2"
62-518-31-1X ■	128C-20	C73-518-5	2	6 1/2"	1"	43/16" 35/8"	1 1/2" —	— 21/2"
62-518-32-1X	128C-20	C102C-521	1	6 1/2"	1"	33/4" 33/4"	1 1/2" —	— 25/8"
62-518-35-1X ▶	128C-20	C62-518-13	2	6 1/2"	1"	43/16" 35/8"	1 1/2" —	— 21/2"
73-518-3	—	C73-518-2	2	5 5/8"	1"	23/4"	3"	—
313243 ▶ 6 Bolt Apron	—	As Purchased	2	6 1/2"	1"	3 19/32"	—	21/2"
313249 ▶ 4 Bolt Apron Slanted 15 deg.	—	As Purchased	2	6 1/2"	1"	3 19/32"	—	21/2"

- ◀ Nodal Mounting
- Side Nodal Mounting
- ▶ Special Ford only

PARTS LISTED IN THIS CATALOG MAY NO LONGER BE AVAILABLE, USE WITH TRANSMISSION SUPERSEDING LIST.

# MODEL CM60 SHIFTER HOUSING ASSEMBLY

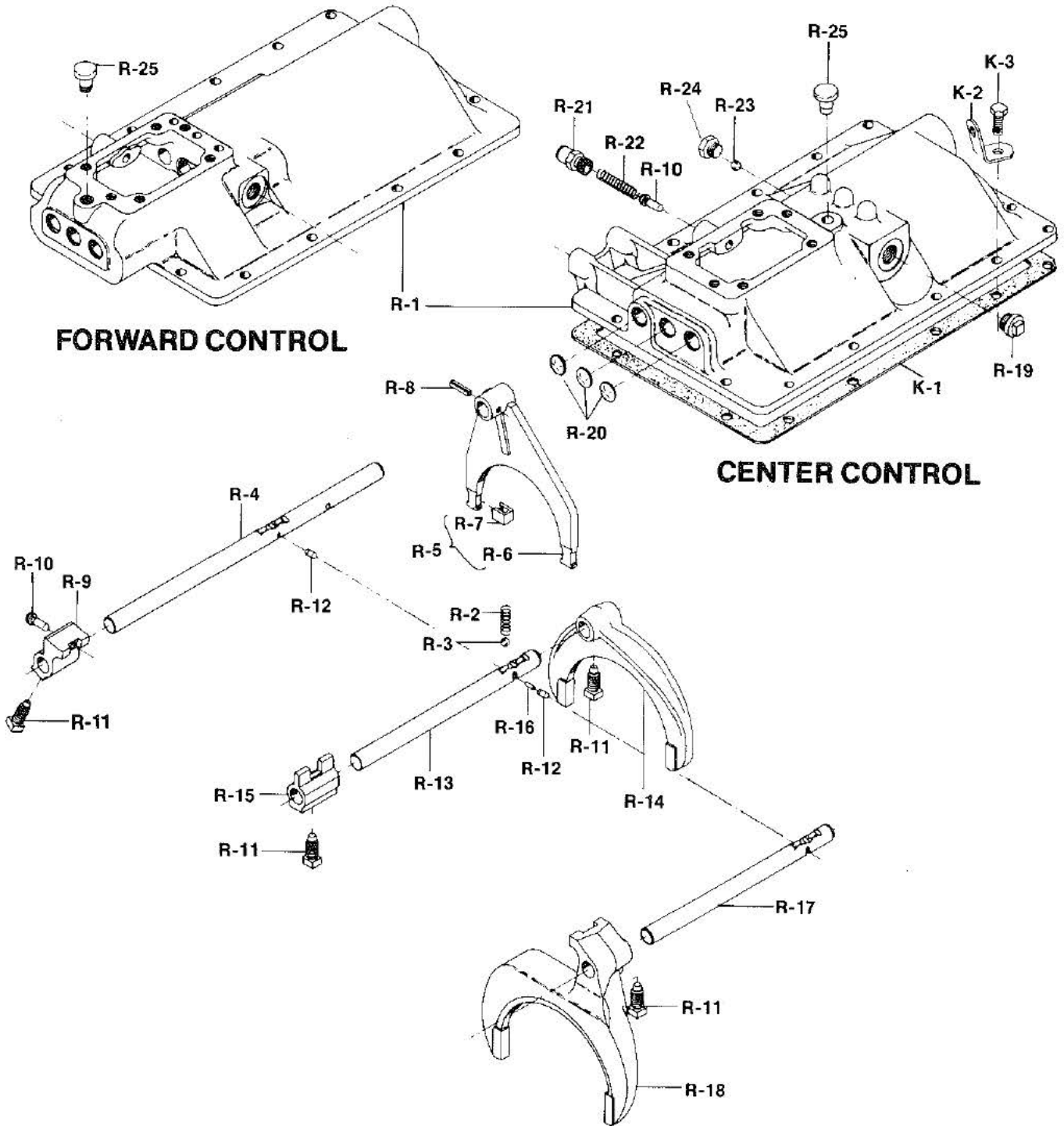



Ref. No.	Part Number	Part Description	Center				Forward						
			63-16-1-1X	63-16-1-2X+	63-16-9-1X	63-16-9-2X*	63-16-3-1X	63-16-3-2X	63-16-3-4X*	63-16-3-5X	63-16-3-6X++	63-16-3-7X**	
	<b>See Tab Bills</b>	<b>Shifter Housing Assembly</b> . . . . .	1	1	1	1	1	1	1	1	1	1	
R-1	<b>63-16-1</b>	Shifter Housing (Casting No. C63-16-2) . . . . .	1	1									
or	<b>63-16-9</b>	Shifter Housing (Casting No. C63-16-2-1) . . . . .			1	1							
or	<b>63-16-3</b>	Shifter Housing (Casting No. C63-16-4) . . . . .					1	1	1	1	1	1	
R-2	<b>47-72-1</b>	Spring—Shift Rod Poppet Ball . . . . .	3	3	3	3	3	3	3	3	3	3	
R-3	<b>50-80-1</b>	Ball—Shift Rod Poppet . . . . .	3	3	3	3	3	3	3	3	3	3	
R-4	<b>63-67-5</b>	Shift Rod—1st and Reverse . . . . .	1	1	1	1							
or	<b>63-67-2</b>	Shift Rod—1st and Reverse . . . . .					1	1	1	1	1	1	
R-5	<b>63-66-1-1X</b>	Shift Fork & Clip Assy.—1st and Reverse . . . . .	1	1	1	1	1	1	1	1	1	1	
R-6	<b>N.S.S.</b>	Shift Fork . . . . .	1	1	1	1	1	1	1	1	1	1	
R-7	<b>46-486-1</b>	Clip . . . . .	2	2	2	2	2	2	2	2	2	2	
R-8	<b>500598-15</b>	Roll Pin—1st and Reverse Shift Rod . . . . .	1	1	1	1	1	1	1	1	1	1	
R-9	<b>63-354-1</b>	Shift Rod Bracket—1st and Reverse . . . . .	1	1	1	1	1	1	1	1	1	1	
R-10	<b>62-438-2</b>	Pin—1st and Reverse Shift Finger Plunger . . . . .	2	2	2	2	2	2	2	2	2	2	
R-11	<b>545063</b>	Screw—Shift Fork and Bracket . . . . .	4	4	4	4	4	4	4	4	4	4	
R-12	<b>32-12-1</b>	Interlock . . . . .	2	2	2	2	2	2	2	2	2	2	
R-13	<b>62-67-22</b>	Shift Rod—2nd and 3rd . . . . .	1	1	1	1							
or	<b>62-67-13</b>	Shift Rod—2nd and 3rd . . . . .					1	1	1	1	1	1	
R-14	<b>62-66-25</b>	Shift Fork—2nd and 3rd . . . . .	1	1	1	1							
or	<b>62-66-20</b>	Shift Fork—2nd and 3rd . . . . .					1	1	1	1	1	1	
R-15	<b>62-354-4</b>	Shift Rod Bracket—2nd and 3rd . . . . .	1	1	1	1	1	1	1	1	1	1	
R-16	<b>289-SP</b>	Pin—Interlock . . . . .	1	1	1	1	1	1	1	1	1	1	
R-17	<b>63-67-4</b>	Shift Rod—4th and 5th . . . . .	1	1	1	1							
or	<b>63-67-3</b>	Shift Rod—4th and 5th . . . . .					1	1	1	1	1	1	
R-18	<b>62-66-27</b>	Shift Fork—4th and 5th . . . . .	1	1	1	1							
or	<b>62-66-22</b>	Shift Fork—4th and 5th . . . . .					1	1	1	1	1	1	
R-19	<b>545021</b>	Plug—Interlock . . . . .	1	1	1	1	1	1	1	1	1	1	
R-20	<b>500166-12</b>	Expansion Plug—7/8" dia. . . . .	3	3	3	3	3	3	3	3	3	3	
R-21	<b>38P-1</b>	Retainer—1st and Reverse Shift Finger Plunger . . . . .	1	1	1	1	1	1	1	1	1	1	
R-22	<b>30-72-6</b>	Spring—1st and Reverse Shift (28 lbs.—2 1/8") . . . . .	1				1						
or	<b>62-72-8</b>	Spring—1st and Reverse Shift (60 lbs.—2 1/64") . . . . .		1									
or	<b>63-72-1</b>	Spring—1st and Reverse Shift (31 lbs.—1 27/32") . . . . .			1	1	1		1			1	
or	<b>82-72-3</b>	Spring—1st and Reverse Shift (15 lbs.—2 3/8") . . . . .							1				
R-23	<b>50-80-4</b>	Ball—Back-up Switch . . . . .	1	1	1	1				1	1		
R-24	<b>330366</b>	Plug—Back-up Switch Hole . . . . .	1	1	1	1	1	1	1	1	1	1	
R-25	<b>312268</b>	Breather Assembly . . . . .	1	1	1	1							
or	<b>4328X</b>	Breather Assembly . . . . .					1	1	1	1	1	1	
<b>Parts Listed Below are not Included in Assembly</b>													
K-1	<b>62-155-8</b>	Gasket—Shifter Housing . . . . .	1	1	1	1	1	1	1	1	1	1	1
K-2	<b>330564-1</b>	Lift Hook . . . . .	2	2	2	2	2	2	2	2	2	2	
K-3	<b>545002-4</b>	Bolt—3/8"-16 x 1 1/8" Hex Head Self-locking . . . . .	14	14	14	14	14	14	14	14	14	14	

\* This Shifter Housing has 5th Speed locked out with a 55-203-15 Sleeve  
 \*\* This Shifter Housing has Rev.,4th & 5th Speed locked out with (1) 22-203-6 Sleeve and (2) 55-203-15 Sleeve (4th & 5th)  
 + Service this Shifter Housing with 63-16-1-1X by replacing 1st & Rev. Spring 30-72-6 with 62-72-8 included with 63-16-1-1X Assy.  
 ++Service this Shifter Housing with 63-16-3-5X by removing the 1st and Rev. Spring 82-72-3  
 N.S.S. Not Sold Separately

# MODEL CM60

## REMOTE CONTROL ASSEMBLY

High Rod Type



T210-CM60

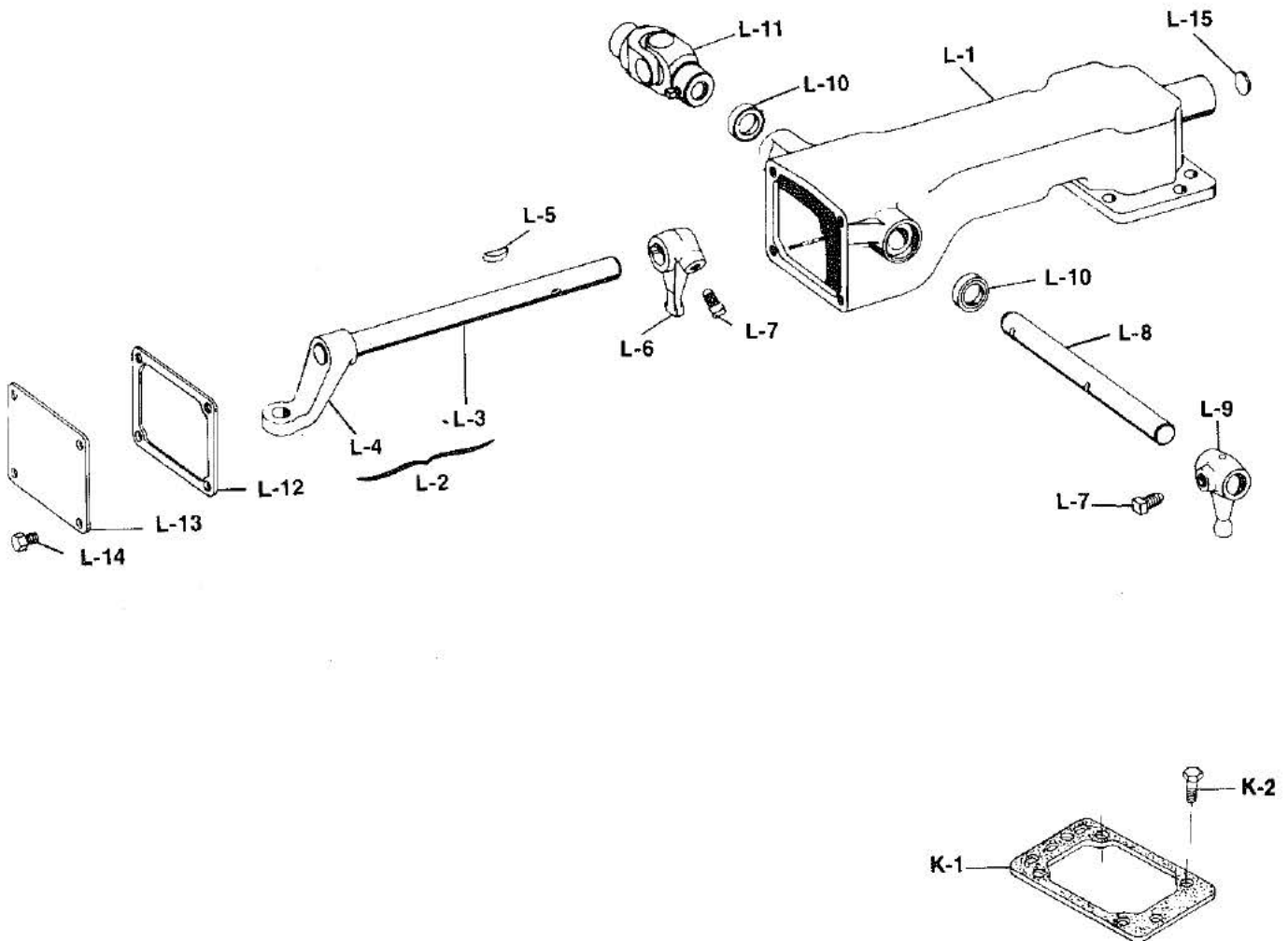

PARTS LISTED IN THIS CATALOG MAY NO LONGER BE AVAILABLE, USE WITH TRANSMISSION SUPERSEDING LIST.





# MODEL CM60

## REMOTE CONTROL ASSEMBLY

### High Rod Type

**T210-CM60**

Ref. No.	Part Number	Part Description	47-16-8-2X	47-16-8-3X	47-16-8-4X	47-16-8-5X	47-16-9-2X	47-16-9-3X	47-16-10-4X	311656-11X
	<b>See Tab Bills</b>	<b>Cover and Joint Assembly—Remote Control</b>	1	1	1	1	1	1	1	1
	47-16-8-1X	Cover Assembly (Casting No. 62-16-78)	1	1	1	1				
	47-16-9-1X	Cover Assembly (Casting No. 62-16-78-1X)					1	1		
	47-16-10-1X	Cover Assembly (Casting No. 62-16-96)							1	
	311860X	Cover Assembly (Casting No. 62-19-96)								1
L-1	N.S.S.	Remote Control Cover	1	1	1	1	1	1	1	1
N.S.	82-24-3	Bushing—Remote Control Cover	4	4	4	4	4	4	4	4
L-2	310647X	Shift Finger Rod and Bracket Assembly	1	1	1	1				
or	310879X	Shift Finger Rod and Bracket Assembly					1	1		
or	311661X	Shift Finger Rod and Bracket Assembly							1	1
L-3	N.S.S.	Rod—Shift Finger	1	1	1	1	1	1	1	1
L-4	N.S.S.	Bracket—Shift Finger Rod	1	1	1	1	1	1	1	1
L-5	500007-19	Woodruff Key—#11	1	1	1	1	1	1	1	1
L-6	62-6-24	Finger—Inner Shift	1	1	1	1	1	1	1	1
L-7	545011	Bolt—7/16"-20 x 7/8" Head Hex Self-locking	2	2	2	2	2	2	2	
or	545063	Bolt—7/16"-20 x 13/16" Square Head Self-locking								2
L-8	82-65-5	Rod—Remote Control Shift	1	1	1	1	1	1		
or	82-65-22	Rod—Remote Control Shift (counter sunk spots at 90 deg.)								1
L-9	82-6-7	Finger—Outer Shift	1	1	1	1	1	1	1	1
L-10	28P-19	Seal—Remote Control Shift Rod	2	2	2	2	2	2	2	2
L-11	10380-SF	U-Joint Assembly—Control	1	1			1	1		1
L-12	82-118-1	Gasket—Aperture Cover	1	1	1	1	1	1	1	1
L-13	82-96-1	Aperture Cover	1	1	1	1	1	1	1	1
L-14	545005-1	Bolt—5/16"-18 x 5/8" Hex Head Self-locking	4	4	4	4	4	4	4	4
L-15	500166-16	Expansion Plug—1 1/16"	1	1	1	1	1	1	1	1
N.S.	311903X	Boot Kit—Remote Control		1		1		1		
N.S.	82-483-1	Boot		1		1		1		
N.S.	82-483-2	Boot—cup type		1		1		1		
N.S.	LW-3	Lockwire		3		3		3		
		<b>Parts Listed below are not Included in Assembly</b>								
K-1	62-155-7	Gasket—Shifter Housing to Control Cover	1	1	1	1	1	1	1	1
K-2	545028-4	Bolt—7/16"-14 x 1 1/4" Hex Head Self-lockint	4	4	4	4	4	4	4	4

N.S.—Not Shown  
N.S.S.—Not Sold Separately

PARTS LISTED IN THIS CATALOG MAY NO LONGER BE AVAILABLE, USE WITH TRANSMISSION SUPERSEDING LIST.

# MODEL CM60

## COMPANION FLANGES, FLANGE YOKES and END YOKES—CASE TABLE



T210-CM60

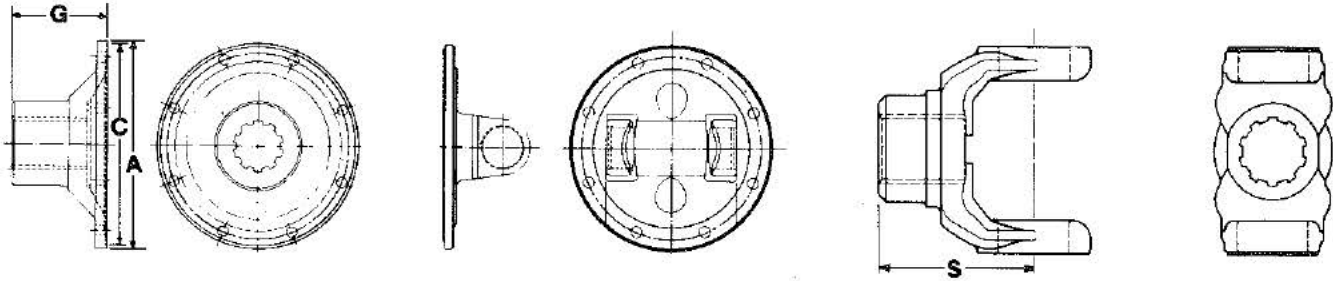

### COMPANION FLANGE

### FLANGE YOKE

### END YOKE

#### Companion Flanges and End Yokes

Joint Series	A Flange Diameter	Companion Flange	G End of Hub to Flange Face Length	C Pilot Diameter F-Female	Mates with Flange Yoke	
					Part No.	Series
1550	5 7/8"	4-1-3781	3 5/8"	F-3 3/4"	4-2-669	1550
1610	6 7/8"	5-1-3141	3 5/8"	F-6 5/8"	5-2-279	1480
1710	8"	6-1-2221	3 1/4"	F-7 3/4"	5-2-779 6-2-749	1650 1700
1810	8"	6.5-1-2121	3 3/4"	F-7 3/4"	6-2-779 6.5-2-359	1710 1810

#### End Yokes

Joint Series	End Yoke Part No.	S End of Hub to Center Line Length	Momentary Joint Angle
1610	5-4-1661	5.000"	22°
1610	5-4-7041-1 *	5.280"	22 1/2°
1710	6-4-2361	5.250"	22°
1710	6-4-3831	5.156"	25°
1710	6-4-3831-1 *	5.160"	25°

\* Half-round Yokes

PARTS LISTED IN THIS CATALOG MAY NO LONGER BE AVAILABLE, USE WITH TRANSMISSION SUPERSEDING LIST.

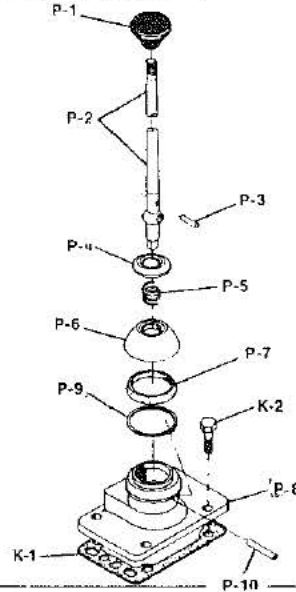

Ref. No.	Part Number	Part Description	47-16-3-1X	47-16-3-3X	47-16-3-25X	47-16-4-7X	47-16-5-9X	47-16-5-21X	47-16-5-22X	47-16-5-38X	47-16-7-10X	47-16-7-31X	47-16-7-29X
		<b>Lever and Dome Assembly—Shift</b>	1	1	1	1	1	1	1	1	1	1	1
P-1	See Tab Bills	Handle—Shift Lever	1	1	1	1	1	1	1	1	1	1	1
P-2	39Q-27	Shift Lever—26 1/4" Straight	1	1	1	1	1	1	1	1	1	1	1
	25Q-1121	Shift Lever—29 1/4" Straight						1					
	25Q-1621	Shift Lever—30" Straight						1					
	25Q-1537	Shift Lever—35" Straight							1				
	25Q-1896	Shift Lever—28" Bent		1									
	25Q-2075	Shift Lever—29 3/16" Bent					1						
	25Q-2163	Shift Lever—31 29/64" Bent									1		
	25Q-2330	Shift Lever—Lower Lever—5.20" Straight										1	
	25Q-2388	Shift Lever—24 5/8" Bent				1							1
	25Q-2316	Shift Lever—Lower Lever 9 7/16" Straight											1
	25Q2315	Shift Lever—26 1/4" Bent											1
N.S.	55Q-5	Grommet—Shift Lever (boot)						1	1	1		1	
N.S.	55Q-14	Grommet—Shift Lever (boot)											1
	47-16-3X	Dome Assembly—2 5/8" overall height	1	1	1								
	47-16-4X	Dome Assembly—3 5/32" overall height				1							
	47-16-5X	Dome Assembly—3 5/8" overall height					1	1	1	1			
	47-16-7X	Dome Assembly—5 5/32" overall height									1	1	1
	47-16-7-28X	Dome Assembly—5 5/32" overall height											1
P-3	286-SP	Pin—Shift lever collar	1	1	1	1	1	1	1	1	1	1	1
P-4	55Q-7	Collar—Compression	1	1	1	1	1	1	1	1	1	1	1
P-5	56Q-25	Spring—Compression	1	1	1	1	1	1	1	1	1	1	1
P-6	54Q-13	Cup—Compression	1	1	1	1	1	1	1	1	1	1	1
P-7	69Q-6	Washer—Friction	1	1	1	1	1	1	1	1	1	1	1
P-8	47-16-3	Dome—Shift Lever (C62-16-24-1)	1	1	1								
	47-16-4	Dome—Shift Lever (C62-16-30-1)				1							
	47-16-5	Dome—Shift Lever (C62-16-67)					1	1	1	1			
	47-16-7	Dome—Shift Lever (C62-16-125)									1	1	1
P-9	62-381-7	Snap Ring—Rock Shaft	1	1	1	1	1	1	1	1	1	1	1
P-10	53Q-15	Shaft—Shift lever rock	1	1	1	1	1	1	1	1	1	1	1
N.S.	500008-15	Key—Shift Lever Upper End											1
N.S.	500389-7	Nut—Shift Lever Upper End											1
N.S.	500024-7	Cotter Pin—Upper Shift Lever											1
		<b>Parts not included in Assembly</b>											
K-1	62-155-7	Gasket—Dome to Shifter Housing	1	1	1	1	1	1	1	1	1	1	1
K-2	545028-4	Screw—7/16"-14 x 1 1/4" Hex head self-locking	4	4	4	4	4	4	4	4	4	4	4

N.S.—Not Shown

# MODEL CM60

**SPICER®**



**T210-CM60**

## CLUTCH RELEASE CODE TABLE

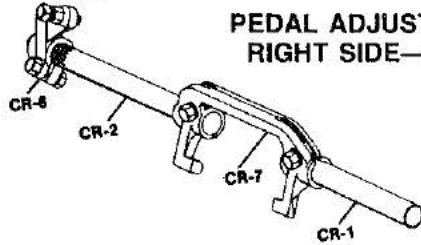

**PEDAL ADJUSTING ARM  
RIGHT SIDE—310473X**

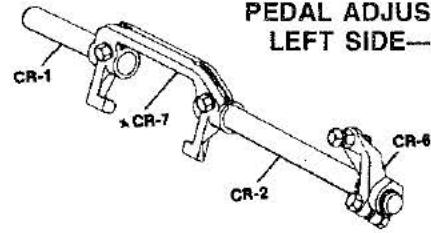

**PEDAL ADJUSTING ARM  
LEFT SIDE—310233X**

**CR-1 SHORT SHAFT**

Part No.	Length
106C-1071	4.062"
106C-1141	5.125"
106C-1142	6.125"
106C-1185	5.750"
106C-1216	4.750"
106C-1278	4.812"
106C-1360	5.312"
106C-1498	6.500"
106C-1544	7.000"
330601-1	6.250"

**CR-2 LONG SHAFT (Cont'd)**

Part No.	Type	Length
106C-1083	RS-8	7.969"
106C-1094	RS-8	8.469"
106C-1123	RS-8	12.968"
106C-1169	RS-8	9.125"
106C-1315	RS-8	7.625"
106C-1367	RS-8	10.312"
106C-1375	RS-8	6.781"
106C-1417	RS-8	7.250"
106C-1422	RS-8	7.500"
106C-1490	RS-8	16.000"
106C-1515	RS-5	11.375"
106C-1529	RS-5	8.312"
330610-5	RS-8	9.469"
330610-11	RS-8	10.750"
46-510-9	RS-5	7.125"
330610-10	RS-8	9.500"



**CR-2 LONG SHAFT**

Part No.	Type	Length
106C-438	RS-5	14.000"
106C-588	RS-5	7.000"
106C-617	RS-8	10.469"
106C-839	RS-8	11.469"
106C-939	RS-8	10.000"
106C-953	RS-8	9.750"
106C-959	RS-8	11.968"
106C-960	RS-8	8.719"
106C-1046	RS-8	8.968"
106C-1047	RS-8	9.469"

**CR-6 PEDAL ADJ. ARM**

- 310233X For Left Side Mtg.
- 310473X For Right Side Mtg.
- 47-526-1-1X\* Lever Type 7 1/4"
- 310873X\* Lever Type 7 1/8"

\*Lever type can be used on either right or left side.

**THRU SHAFT (used with Push Type Clutch)**

Part No.	Type	Length
106C-1566	Splined	19.125"
106C-1550	Keyed	16.375"
106C-1558	Keyed	19.000"
106C-1578	Splined	19.500"
49-510-1	Keyed	19.120"
97-510-2	Splined	19.313"

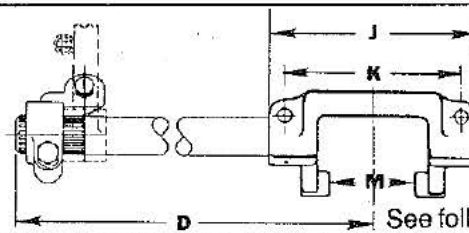

See following page for "D" dimensions.

**CLUTCH RELEASE YOKES**

CR-7	Forging No.	Used With	Type	J	K	M
105C-64	F105C64	Spicer 15 1/2" SP	Pull	8.000"	6.500"	4.895"
105C-68	F105C99	Spicer 14" SP	Pull	7.125"	5.750"	4.132"
105C-117 <sup>1</sup>	F105C118	Spicer & Others	Push	8.375"	7.000"	4.885"
105C-124 <sup>2</sup>	F105C125	Spicer AL & AR	Push	3.750"	2.125"	2.885"
105C-132 <sup>2</sup>	F105C118	Spicer & Others	Push	8.375"	7.000"	4.885"
105C-137	F105C138	Spicer 15 1/2" and 14" 2P	Pull	8.000"	6.500"	4.895"
85-509-3 <sup>3</sup>	F105C118	Spicer & Others	Push	8.375"	7.000"	4.885"

<sup>1</sup>Machined washer surface on yoke front

<sup>2</sup>Machined washer surface on yoke rear (for clearance)

<sup>3</sup>Same as <sup>1</sup> above except contains spring holes in lugs

<sup>4</sup>Use 7743X Clutch Release Bearing and (2) 2306-12 Springs.

★ CLUTCH RELEASE YOKE ATTACHING PARTS—

Use one KEY 10-30, two SCREWS 330231 and two LOCK WASHERS 500356-12

NOTE: When changing from a two plate to single plate clutch or vice versa, a different bearing cap will be required.



# MODEL CM60

## BASIC OVERHAUL KITS



T210-CM60

Part Number	Part Description	Qty.
313400-57X	<b>Major Overhaul Kit</b> .....	1
500010-8	Woodruff Key—Countershaft 2nd,3rd,4th, & C/S Drive Gear .....	4
500898	Nut—Mainshaft .....	1
425-SP	Pin—4th Mainshaft Gear Sleeve .....	1
313432-20X	Minor Overhaul Kit .....	1
313429-14X	Shifter Housing Small Parts Repair Kit .....	1
313401-14X	Thrust Washer Kit .....	1
313432-20X	<b>Minor Overhaul Kit (included in Major Overhaul Kit)</b> .....	1
	<b>Bearings</b>	
500936	Countershaft Rear Taper Cone .....	1
550183	Rear Output Front Cone .....	1
550228	Rear Output Front Cup .....	1
550612	Mainshaft Rear Cone .....	1
550886	Roller Assy. Reverse Idler Gear .....	2
550929	Drive Gear Cup .....	1
550929	Mainshaft Rear Cup .....	1
550930	Drive Gear Cone .....	1
550933	Countershaft Front Cup .....	1
550934	Countershaft Front Cone .....	1
550935	Countershaft Rear Taper Cup .....	1
550938	1st and Reverse Mainshaft Needle Assy. ....	2
550983	Needle Split 2nd Gear .....	1
60-463-8	Oil Seal—Rear Bearing Cap (3.756" O.D.) .....	1
60-463-10-1X	Oil Seal Kit (w/installation sleeves)—Drive Gear Brg. Cap .....	1
545077	Bearing Lubricant—Packet .....	1
545080	Anaerobic Sealant—Mainshaft Nut .....	1
2342-5	Service Manual .....	1
2734	Bulletin—Thrust Washer Installation .....	1
2759	Bulletin—Drive Gear Replacement .....	1
2770	Bulletin—Pocket Bearing Lubrication .....	1
2783	Bulletin—Mainshaft Nut Anaerobic Sealant .....	1
312475-29X	Gasket Kit .....	1
313024-22X	Snap Ring Kit .....	1
313240-3X	Baffle and Shim Kit—Drive Gear .....	1
313439X	Countershaft Rear Bearing Shim Kit .....	1
313429-14X	<b>Shifter Housing Small Parts Repair Kit (Included in Major Overhaul Kit)</b> .....	1
38P-1	Retainer—1st and Rev. Shift Finger Plunger .....	1
289-SP	Pin—Interlock .....	1
30-72-6	Spring—1st and Rev. Shift Finger Plunger .....	1
32-12-1	Interlock .....	2
32-59-3	Plug—Shift Rod Thimble .....	1
500166-12	Plug—Shift Rod Hole Expansion .....	3
500598-15	Pin—1st and Reverse Shift Rod Roll .....	1
47-72-1	Spring—Shift Rod Poppet Ball .....	3
50-80-1	Ball—Shift Rod Poppet .....	3
62-438-2	Pin—1st and Reverse Shift Finger Plunger .....	2

PARTS LISTED IN THIS CATALOG MAY NO LONGER BE AVAILABLE, USE WITH TRANSMISSION SUPERSEDING LIST.



Part Number	Part Description	Qty.
313401-14X	<b>Thrust Washer Kit (Included in Major Overhaul Kit)</b> .....	1
330871	Mainshaft Rear .....	1
974-W	Reverse Idler Bearing .....	2
330884	1st and 2nd Speed Mainshaft Gear .....	1
1001-W	4th Speed Mainshaft Gear .....	1
312475-29X	<b>Gasket Kit (Included in Minor Overhaul Kits)</b> .....	1
62-155-7	Control Housing .....	1
62-155-8	Shifter Housing .....	1
63-223-1	Countershaft Rear Bearing Cap .....	1
63-223-2	Drive Gear Bearing Cap .....	1
63-223-3	Mainshaft Rear Bearing Cap .....	1
63-223-4	Drive Gear Bearing Cap (Ford) .....	1
63-223-5	Countershaft Front Bearing Cap (Ford) .....	1
63-223-6	Mainshaft Rear Bearing Cap (Bendix Brake Cap) .....	1
63-223-7	Mainshaft Rear Bearing Cap (Ford) .....	1
82-118-1	Remote Control Aperture Cover .....	1
97-324-1-1X	PTO (6 Bolt) Kit .....	1
97-324-2-1X	PTO (8 Bolt) Kit .....	1
2749	Bulletin—Gasket Installation .....	1
313024-22X	<b>Snap Ring Kit (Included in Minor Overhaul Kit)</b> .....	1
62-381-4	4th Speed Mainshaft Gear .....	1
62-381-8	2nd and 3rd Speed Mainshaft Gear .....	1
63-381-1	1st and 2nd Speed Mainshaft Gear .....	1
70-381-6	Countershaft Drive Gear .....	1
313240-3X	<b>Baffle and Shim Kit (Included in Minor Overhaul Kit)</b> .....	1
47-228-1-1	Mainshaft Bearing .....	9
47-228-2-2	Mainshaft Front Bearing .....	1
47-228-2-10	Spacer—Mainshaft Rear .....	1
47-468-1	Baffle .....	1
47-468-2	Baffle—Oil Ring .....	1
2789	Bulletin—Baffle and Shim Kit Installation .....	1
313439X	<b>Shim Kit—C/S Rear Bearing (Included in Minor Overhaul Kit)</b> .....	1
63-228-2-1	Shim—Rear Bearing .....	4
2759	Bulletin- Drive Gear Replacement .....	1
312477-36X	<b>Small Parts Repair Kit (Not included in any Overhaul Kit)</b>	
50-80-1	Ball—Shift Rod Poppet .....	3
32-12-1	Interlock .....	2
500010-8	Key—2nd Countershaft Gear .....	1
500010-8	Key—3rd, 4th & Countershaft Drive Gear .....	3
289-SP	Pin—Interlock .....	1
62-438-2	Pin—1st & Reverse Shift Finger Plunger .....	2
500598-15	Pin—1st & Reverse Shift Rod Roll .....	1
500166-12	Plug—Shift Rod Hole Expansion .....	3
32-59-3	Plug—Shift Rod Thimble .....	1
38P-1	Retainer—1st & Reverse Shift Finger Plunger .....	1
70-381-6	Ring—Countershaft Drive Gear Snap .....	1
63-381-1	Ring—1st & 2nd Mainshaft Gear Snap .....	1
62-381-8	Ring—2nd & 3rd Mainshaft Clutch Gear Snap .....	1
62-381-4	Ring—4th Mainshaft Gear Thrust Washer Snap .....	1
47-72-1	Spring—Shift Rod Poppet Ball .....	3
30-72-6	Spring—1st & Reverse Shift Finger Plunger .....	1

# MODEL CM60

## SUPPRESSION LIST OF CM60 TO ES65-5 BILLS OF MATERIAL



T210-CM60

6052A	6052A	6052A	ES65-5A	6052A	6052A	6052A	ES65-5A
301075-1	301253-1	301413-1	301466-24	301075-55	301253-55	301413-55	
301075-2	301253-2	301413-2	301466-37	301075-56	301253-56	301413-56	301466-21
301075-3	301253-3	301413-3		301075-57	301253-57	301413-57	
301075-4	None	None		301075-58	301253-58	301413-58	301466-6
301075-5	None	None		—	301253-59	301413-59	
301075-6	301253-6	301412-6	301466-32	—	301253-60	301413-60	
301075-7	None	None		—	301253-61	301413-61	301466-7
301075-8	301253-8	301413-8	301466-23	—	301253-62	301413-62	
301075-9	None	None		—	301253-63	301413-63	301466-35
301075-10	301253-10	301413-10	301466-38	—	301253-64	301413-64	301466-36
301075-11	301253-11	None		—	301253-65	301413-65	301466-8
301075-12	301253-12	301413-12	301466-26	—	301253-66	301413-66	
301075-13	None	None		—	301253-67	301413-67	301466-9
301075-14	301253-14	None		—	301253-68	301413-68	
301075-15	301253-15	None		—	301253-69	301413-69	
301075-16	301253-16	301413-16		—	301253-70	301413-70	
301075-17	301253-17	301413-17		—	301253-71	301413-71	
301075-18	301253-18	301413-18		—	301253-72	301413-72	
301075-19	301253-19	301413-19	301466-39	—	301253-73	301413-73	301466-28
301075-20	301253-20	301413-20	301466-40	—	301253-74	301413-74	
301075-21	301253-21	301413-21	301466-27	—	301253-75	301413-75	
301075-22	301253-22	301413-22		—	301253-76	301413-76	
301075-23	301253-23	None		—	301253-77	301413-77	
301075-24	301253-24	301413-24		—	301253-78	301413-78	
301075-25	301253-25	301413-25		—	301253-79	301413-79	301466-10
301075-26	301253-26	301413-26		—	301253-80	301413-80	
301075-27	301253-27	301413-27	301466-33	—	301253-81	301413-81	301466-25
301075-28	301253-28	301413-28		—	301253-82	301413-82	
301075-29	301253-29	301413-29		—	301253-83	301413-83	
301075-30	301253-30	301413-30	301466-1	—	301253-84	301413-84	
301075-31	301253-31	301413-31		—	301253-85	301413-85	
301075-32	301253-32	301413-32		—	301253-86	301413-86	
301075-33	301253-33	301413-33		—	301253-87	301413-87	
301075-34	301253-34	301413-34	301466-3	—	301253-88	301413-88	
301075-35	301253-35	301413-35	301466-4	—	301253-89	301413-89	301466-29
301075-36	301253-36	301413-36		—	301253-90	301413-90	301466-30
301075-37	301253-37	301413-37		—	301253-91	301413-91	301466-11
301075-38	301253-38	301413-38		—	301253-92	301413-92	
301075-39	301253-39	301413-39	301466-2	—	301253-93	301413-93	301466-12
301075-40	301253-40	301413-40		—	301253-94	301413-94	301466-13
301075-41	301253-41	301413-41		—	301253-95	301413-95	301466-14
301075-42	301253-42	301413-42		—	301253-96	301413-96	301466-31
301075-43	301253-43	301413-43		—	301253-97	301413-97	301466-15
301075-44	301253-44	301413-44		—	301253-98	301413-98	
301075-45	301253-45	301413-45		—	301253-99	301413-99	
301075-46	301253-46	301413-46		—	—	301413-100	
301075-47	None	None		—	—	301413-101	301466-16
301075-48	301253-48	301413-48	301466-34	—	—	301413-102	
301075-49	None	None		—	—	301413-103	
301075-50	301253-50	301413-50	301466-5	—	—	301413-104	301466-17
301075-51	301253-51	301413-51		—	—	—	301466-18
301075-52	301253-52	301413-52		—	—	—	301466-19
301075-53	301253-53	301413-53		—	—	—	301466-20
301075-54	301253-54	301413-54		—	—	—	301466-22

PARTS LISTED IN THIS CATALOG MAY NO LONGER BE AVAILABLE, USE WITH TRANSMISSION SUPERSEDING LIST.





# MODEL CM60

## SUPERSESSON LIST OF CM 60 TO ES65-5 BILLS OF MATERIAL

T210-CM60

6052B	6052B	6052B	ES65-5B	6052B	6052B	6052B	ES65-5B
301082-1	301254-1	301414-1		(Cont'd)			
301082-2	301254-2	301414-2	301467-10	—	301254-56	301414-56	
301082-3	None	None		—	301254-57	301414-57	
301082-4	301254-4	None		—	301254-58	301414-58	
301082-5	None	None		—	301254-59	301414-59	
301082-6	None	None		—	301254-60	301414-60	
301082-7	301254-7	None		—	301254-61	301414-61	
301082-8	301254-8	None		—	301254-62	301414-62	
301082-9	301254-9	None		—	301254-63	301414-63	301467-5
301082-10	301254-10	301414-10		—	301254-64	301414-64	
301082-11	301254-11	301414-11		—	—	301414-65	301467-8
301082-12	301254-12	301414-12		—	—	301414-66	301467-6
301082-13	301254-13	301414-13		—	—	301414-67	301467-7
301082-14	None	None		—	—	—	301467-12
301082-15	301254-15	301414-15					
301082-16	301254-16	301414-16					
301082-17	301254-17	301414-17	301467-3	<b>6052C</b>	<b>6052C</b>	<b>6052C</b>	<b>ES65-5E</b>
301082-18	301254-18	301414-18	301467-4				
301082-19	301254-19	301414-19	301467-9	301083-1	301255-1	301415-1	301468-1
301082-20	301254-20	301414-20		301083-2	None	None	
301082-21	301254-21	301414-21		301083-3	301255-3	301415-3	
301082-22	301254-22	301414-22		301083-4	301255-4	None	
301082-23	301254-23	301414-23		301083-5	None	None	
301082-24	301254-24	301414-24		301083-6	301255-6	301415-6	
301082-25	301254-25	301414-25		301083-7	301255-7	301415-7	301468-2
301082-26	301254-26	301414-26		301083-8	301255-8	301415-8	301468-5
301082-27	301254-27	301414-27		301083-9	None	None	
301082-28	301254-28	301414-28		301083-10	None	None	
301082-29	None	None		301083-11	301255-11	301415-11	
301082-30	301254-30	301414-30		301083-12	None	None	
301082-31	301254-31	301414-31		301083-13	301255-13	301415-13	
301082-32	301254-32	301414-32		301083-14	301255-14	301415-14	301468-16
301082-33	301254-33	301414-33	301467-11	301083-15	301255-15	301415-15	
—	301254-34	301414-34		301083-16	301255-16	301415-16	301468-6
—	301254-35	301414-35	301467-1	301083-17	301255-17	301415-17	
—	301254-36	301414-36		301083-18	301255-18	301415-18	301468-18
—	301254-37	301414-37		301083-19	None	None	
—	301254-38	301414-38		301083-20	None	None	
—	301254-39	301414-39		301083-21	301255-21	301415-21	
—	301254-40	301414-40		301083-22	301255-22	301415-22	
—	301254-41	301414-41		301083-23	301255-23	301415-23	301468-22
—	301254-42	301414-42		301083-24	301255-24	301415-24	301468-4
—	301254-43	301414-43		301083-25	301255-25	301415-25	
—	301254-44	301414-44		301083-26	301255-26	301415-26	301468-23
—	301254-45	301414-45		301083-27	301255-27	301415-27	
—	301254-46	301414-46		301083-28	301255-28	301415-28	301468-19
—	301254-47	301414-47		301083-29	301255-29	301415-29	
—	301254-48	301414-48		301083-30	None	None	
—	301254-49	301414-49		301083-31	301255-31	301415-31	
—	301254-50	301414-50		301083-32	None	None	
—	301254-51	301414-51		301083-33	301255-33	301415-33	301468-7
—	301254-52	301414-52		301083-34	301255-34	301415-34	301468-8
—	301254-53	301414-53	301467-2	301083-35	301255-35	301415-35	
—	301254-54	301414-54		—	301255-36	301415-36	
—	301254-55	301414-55		—	301255-37	301415-37	

PARTS LISTED IN THIS CATALOG MAY NO LONGER BE AVAILABLE, USE WITH TRANSMISSION SUPERSEDING LIST.

# MODEL CM60

## SUPERSESSION LIST OF CM60 TO ES65-5 BILLS OF MATERIAL

**SPICER®**



**T210-CM60**

6052C	6052C	6052C	ES65-5E	6252A	6252A	6252A	ES65-5
—	None	None		301084-1	301257-1	None	None
—	301255-39	301415-39		301084-2	301257-2	None	None
—	301255-40	301415-40		301084-3	301257-3	None	None
—	301255-41	301415-41	301468-21	301084-4	301257-4	None	None
—	301255-42	301415-42	301468-9	301084-5	301257-5	None	None
—	301255-43	301415-43	301468-26	301084-6	301257-6	None	None
—	301255-44	301415-44		301084-7	301257-7	None	None
—	301255-45	301415-45		301084-8	301257-8	None	None
—	301255-46	301415-46		—	301257-9	None	None
—	None	None					
—	301255-48	301415-48		<b>6252B</b>	<b>6252B</b>	<b>6252B</b>	<b>ES65-5</b>
—	301255-49	301415-49		301085-1	301258-1	301417-1	None
—	301255-50	301415-50	301468-10	301085-2	301258-2	301417-2	None
—	301255-51	301415-51		301085-3	301258-3	301417-3	None
—	301255-52	301415-52		301085-4	None	None	None
—	301255-53	301415-53		301085-5	301258-5	301417-5	None
—	301255-54	301415-54	301468-11	301085-6	301258-6	301417-6	None
—	301255-55	301415-55		301085-7	301258-7	301417-7	None
—	301255-56	301415-56		301085-8	301258-8	301417-8	None
—	301255-57	301415-57	301468-12	301085-9	301258-9	301417-9	None
—	301255-58	301415-58	301468-13	301085-10	301258-10	301417-10	None
—	301255-59	301415-59	301468-20	301085-11	301258-11	301417-11	None
—	301255-60	301415-60	301468-14	301085-12	301258-12	301417-12	None
—	301255-61	301415-61	301468-17	301085-13	301258-13	301417-13	None
—	—	301415-62		301085-14	301258-14	301417-14	None
—	—	301415-63	301468-15	301085-15	301258-15	301417-15	None
—	—	301415-64		301085-16	301258-16	301417-16	None
—	—	—	301468-24	301085-17	301258-17	301417-17	None
—	—	—	301468-25	301085-18	301258-18	301417-18	None
—	—	—	301468-28	301085-19	301258-19	301417-19	None
<b>6052D</b>	<b>6052D</b>	<b>6052D</b>	<b>ES65-5D</b>	301085-20	301258-20	301417-20	None
301157-1	None	None		301085-21	301258-21	301417-21	None
301157-2	301256-2	301416-2	301469-1	301085-22	301258-22	301417-22	None
301157-3	301256-3	301416-3	301469-2	301085-23	301258-23	301417-23	None
—	None	None		301085-24	301258-24	301417-24	None
—	301256-5	301416-5		301085-25	301258-25	301417-25	None
—	301256-6	301416-6		301085-26	301258-26	301417-26	None
—	301256-7	301416-7		301085-27	301258-27	301417-27	None
—	301256-8	301416-8		301085-28	301258-28	301417-28	None
—	301256-9	301416-9	301469-5	301085-29	301258-29	301417-29	None
—	301256-10	301416-10	301469-12	—	301258-30	301417-30	None
—	301256-11	301416-11		—	301258-31	301417-31	None
—	301256-12	301416-12		—	301258-32	301417-32	None
—	301256-13	301416-13		—	301258-33	301417-33	None
—	301256-14	301416-14		—	301258-34	301417-34	None
—	301256-15	301416-15		—	301258-35	301417-35	None
—	301256-16	301416-16	301469-6	—	301258-36	301417-36	None
—	301256-17	301416-17		—	301258-37	301417-37	None
—	301256-18	301416-18		—	301258-38	301417-38	None
—	301256-19	301416-19	301469-7	—	301258-39	301417-39	None
—	301256-20	301416-20	301469-8	—	301258-40	301417-40	None
—	301256-21	301416-21		—	301258-41	301417-41	None
—	—	301416-22		—	301258-42	301417-42	None
—	—	301416-23		—	301258-43	301417-43	None
—	—	301416-24	301469-9	—	301258-44	301417-44	None
—	—	301416-25	301469-10				

PARTS LISTED IN THIS CATALOG MAY NO LONGER BE AVAILABLE, USE WITH TRANSMISSION SUPERSEDING LIST.

**SPICER®****MODEL CM60****SUPERSESSON LIST OF CM60 TO ES65-5  
BILLS OF MATERIAL****T210-CM60**

<b>6253A</b>	<b>6253A</b>	<b>6253A</b>	<b>ES65-5</b>	<b>6253B</b>	<b>6253B</b>	<b>6253B</b>	<b>ES65-5</b>
301086-1	301259-1	None	None	301087-5	301260-5	301418-5	None
301086-2	301259-2	None	None	301087-6	301260-6	301418-6	None
301086-3	301259-3	None	None	301087-7	301260-7	301418-7	None
301086-4	None	None	None	301087-8	301260-8	301418-8	None
301086-5	301259-5	None	None	301087-9	301260-9	301418-9	None
301086-6	None	None	None	301087-10	301260-10	301418-10	None
301086-7	301259-7	None	None	301087-11	301260-11	301418-11	None
301086-8	301259-8	None	None	301087-12	None	None	None
301086-9	301259-9	None	None	301087-13	301260-13	301418-13	None
301086-10	301259-10	None	None	301087-14	None	None	None
301086-11	301259-11	None	None	301087-15	301260-15	301418-15	None
301086-12	301259-12	None	None	301087-16	301260-16	301418-16	None
301086-13	301259-13	None	None	301087-17	301260-17	301418-17	None
301086-14	301259-14	None	None	301087-18	301260-18	301418-18	None
301086-15	301259-15	None	None	301087-19	301260-19	301418-19	None
301086-16	None	None	None	—	301260-20	301418-20	None
301086-17	301259-17	None	None	—	301260-21	301418-21	None
301086-18	301259-18	None	None	—	301260-22	301418-22	None
301086-19	301259-19	None	None	—	301260-23	301418-23	None
301086-20	301259-20	None	None	—	301260-24	301418-24	None
301086-21	301259-21	None	None	—	301260-25	301418-25	None
—	301259-22	None	None	—	301260-26	301418-26	None
—	301259-23	None	None	—	301260-27	301418-27	None
—	301259-24	None	None	—	301260-28	301418-28	None
—	301259-25	None	None	—	301260-29	301418-29	None
—	301259-26	None	None	—	301260-30	301418-30	None
—	301259-27	None	None	—	301260-31	301418-31	None
<b>6253B</b>	<b>6253B</b>	<b>6253B</b>	<b>ES65-5</b>	—	—	301418-32	None
301087-1	301260-1	301418-1	None	—	—	301418-33	None
301087-2	301260-2	301418-2	None	—	—	301418-34	None
301087-3	301260-3	301418-3	None	—	—	301418-35	None
301087-4	301260-4	301418-4	None	—	—	301418-36	None

PARTS LISTED IN THIS CATALOG MAY NO LONGER BE AVAILABLE, USE WITH TRANSMISSION SUPERSEDING LIST.

# MODEL CM60

**SPICER®**



**T210-CM60**

## TABULATED BILLS OF MATERIAL

Tab No.	Used By	For Use With Clutch	CLUTCH HOUSING			Main Drive Gear A-1	Drive Gear Bearing Cap F-2	Case Assembly G-1
			S A E	Assembly No.	Rel. Code Pages 18-19			
<b>Model 6052A</b>								
<b>301075</b>								
-1	Service	Pull Type	2	62-518-29-1X	—	63-35-1*	63-19-1-1X**	63-15-1-1X
-2	Service	Pull Type	2	62-518-29-1X	—	63-35-1*	63-19-1-1X**	63-15-1-1X
-3	Service	Push Type	2	62-518-27-1X	—	63-35-3*	63-19-23-1X**	63-15-1-1X
-4	Ford	Push Type	—	—	—	63-35-18*	63-19-20-1X**	63-15-11-1X
-5	Ford	Push Type	2	313243	—	63-35-15*	63-19-21-1X**	63-15-5-1X++
-6	Navistar	Push Type	—	—	—	63-35-14*	63-19-4-1X**	63-15-10-1X***
-7	Ford	Push Type	2	62-518-35-1X	—	63-35-15*	63-19-21-1X**	63-15-5-1X++
-8	Harnischfeger	Push Type	2	62-518-29-1X	42	63-35-1*	63-19-17-3-1X**	63-15-1-1X
-9	Ford	Pull Type	2	62-518-30-1X	—	63-35-1*	63-19-1-1X**	63-15-5-1X++
-10	AM General	Pull Type	2	62-518-29-1X	94	63-35-1*	63-19-1-1X**	63-15-1-1X
-11	Oshkosh (Africa)	Push Type	2	62-518-29-1X	40	63-35-1*	63-19-17-3-1X**	63-15-1-1X
-12	Mack	Pull Type	2	62-518-36-1X	—	63-35-1*	63-19-1-1X**	63-15-1-1X
-13	Ford	Push Type	2	313249	—	63-35-15*	63-19-12-1X**	63-15-11-1X
-14	Mack	Pull Type	2	62-518-29-1X	—	63-35-1*	63-19-1-1X**	63-15-1-1X
-15	White	Pull Type	2	62-518-29-1X	—	63-35-1*	63-19-1-1X**	63-15-1-1X
-16	Volvo GM	Pull Type	2	62-518-29-1X	—	63-35-1*	63-19-1-1X**	63-15-1-1X
-17	Gardner-Denver	Pull Type	2	62-518-29-1X	84	63-35-1*	63-19-1-1X**	63-15-1-1X
-18 §	GMC	—	—	—	—	63-35-1*	63-19-17-3-1X**	63-15-1-3X
-19	GMC	Push Type	2	312098X	—	63-35-13*	63-19-17-2-1X**	63-15-1-3X
-20	Volvo GM	Push Type	2	62-518-29-1X	—	63-35-1*	63-19-17-3-1X**	63-15-1-1X
-21 §	GMC	—	—	—	—	63-35-13*	63-19-17-2-1X**	63-15-3-1X
-22	Kenworth	Pull Type	2	62-518-29-1X	84	63-35-1*	63-19-1-1X**	63-15-1-2X
-23	Ford	Push Type	2	313243	—	63-35-15*	63-19-15-1X**	63-15-15-1X
-24	Spartan Motors	Pull Type	2	62-518-29-1X	88	63-35-1*	63-19-1-1X**	63-15-1-1X
-25	Navistar	Pull Type	2	62-518-29-1X	—	63-35-1*	63-19-1-1X**	63-15-10-2X***
-26	Service	Pull Type	2	62-518-29-1X	59	63-35-1*	63-19-1-1X**	63-15-1-1X
-27	Service	Pull Type	1	62-518-32-1X	59	63-35-1*	63-19-1-1X**	63-15-1-1X
-28	Cooper	Pull Type	1	62-518-32-1X	80	63-35-1*	63-19-1-1X**	63-15-1-1X
-29	Cooper	Pull Type	1	62-518-32-1X	80	63-35-1*	63-19-1-1X**	63-15-1-1X
-30	Navistar	Pull Type	2	62-518-29-1X	—	63-35-1*	63-19-1-1X**	63-15-10-1X***
-31	Spartan	Push Type	2	62-518-29-1X	22	63-35-1*	63-19-17-3-1X**	63-15-1-1X
-32	GMC	Push Type	2	312098X	—	63-35-13*	63-19-17-2-1X**	63-15-1-3X
-33	Service	Pull Type	—	—	—	63-35-1*	63-19-1-1X**	63-15-10-1X***
-34 §	Service	Push Type	—	—	—	63-35-3*	63-19-23-1X**	63-15-1-1X
-35 §	Service	Push Type	—	—	—	63-35-1*	63-19-17-3-1X**	63-15-1-1X
-36	Hendrickson	Pull Type	2	62-518-29-1X	84	63-35-1*	63-19-1-1X**	63-15-1-1X
-37	Navistar	Pull Type	—	—	—	63-35-1*	63-19-1-1X**	63-15-10-1X***
-38	GMC	Push Type	—	—	—	63-35-1*	63-19-17-3-1X**	63-15-1-3X
-39	Navistar	Push Type	2	73-518-3	—	63-35-14*	63-19-4-1X**	63-15-10-1X***
-40	Scot LTD	Pull Type	1	62-518-32-1X	—	63-35-1*	63-19-1-1X**	63-15-1-1X

§ Short Box

\* These parts have been superseded—see page 6 for Service Part

\*\* These parts have been superseded—see page 7 for Service Part

\*\*\* This part has been superseded by 63-15-1-1X for Service.

++ This part has been superseded by 63-15-15-1X for Service

PARTS LISTED IN THIS CATALOG MAY NO LONGER BE AVAILABLE, USE WITH TRANSMISSION SUPERSEDING LIST.



# MODEL CM60

## TABULATED BILLS OF MATERIAL

T210-CM60

Tab No.	Mainshaft Rear Bearing Cap Assembly H-1 (incl. Bushing, Seal)	SPEEDOMETER		End Yoke or Companion Flange Page 16	SHIFTER		
		Drive Gear or Signal Gear B-24	Driven Gear H-7		Housing Ass'y Pages 12-13	Lever & Dome Ass'y Page 17	Remote Control Pages 14-15
<b>Model CM6052A</b>							
<b>301075</b>							
-1	63-19-6-2X	62-452-3	62-453-4	6-4-2361	63-16-1-1X	—	—
-2	63-19-6-2X	62-452-3	62-453-4	6-4-2361	63-16-3-1X	—	—
-3	63-19-6-2X	62-452-3	62-453-4	6-4-2361	63-16-3-1X	—	—
-4	•47-360-1	—	—	—	63-16-1-1X	—	—
-5	•47-360-1	—	—	—	63-16-1-1X	—	—
-6	63-19-10-2X	63-452-1	—	—	63-16-1-2X	—	—
-7	•47-360-1	—	—	—	63-16-3-2X	—	—
-8	63-19-6-2X	—	—	5-4-1661	63-16-3-5X	—	47-16-8-2X
-9	•47-360-1	—	—	—	63-16-1-1X	—	—
-10	63-19-6-2X	62-452-9	62-453-8	6.5-1-2121	63-16-3-1X	—	47-16-9-2X
-11	63-19-6-2X	62-452-3	62-453-5	5-4-1661	63-16-3-2X	—	47-16-8-2X
-12	63-19-6-2X	—	—	—	63-16-1-1X	—	—
-13	•47-360-1	—	—	—	63-16-1-1X	—	—
-14	63-19-6-2X	—	—	—	63-16-1-1X	—	—
-15	63-19-6-2X	—	—	—	63-16-3-1X	—	—
-16	63-19-6-2X	—	—	—	63-16-1-1X	—	—
-17	63-19-6-2X	—	—	6-1-2221	63-16-3-1X	47-16-3-3X	—
-18	63-19-6-2X	—	—	—	—	—	—
-19	63-19-6-2X	62-452-9	—	—	63-16-9-1X	—	—
-20	63-19-6-2X	—	—	—	63-16-3-1X	—	—
-21	63-19-6-2X	—	—	—	—	—	—
-22	63-19-6-2X	62-452-3	62-453-5	6-4-2361	63-16-1-1X	47-16-3-3X	—
-23	•47-360-1	—	—	—	63-16-1-1X	—	—
-24	63-19-6-2X	62-452-3	62-453-5	5-1-3141	63-16-1-1X	—	47-16-8-2X
-25	63-19-8-2X	63-452-1	—	—	63-16-1-2X	—	—
-26	63-19-6-2X	—	—	4-1-3781	63-16-3-1X	47-16-3-3X	—
-27	63-19-6-2X	—	—	5-1-3141	63-16-3-1X	—	47-16-8-2X
-28	63-19-6-2X	62-452-3	62-453-4	—	63-16-3-1X	—	47-16-8-2X
-29	63-19-6-2X	62-452-3	62-453-4	—	63-16-3-1X	47-16-3-1X	—
-30	63-19-10-2X	63-452-1	—	—	63-16-1-2X	—	—
-31	63-19-6-2X	62-452-3	62-453-5	5-1-3141	63-16-1-1X	—	47-16-8-2X
-32	63-19-6-2X	62-452-9	—	5-4-1661	63-16-9-1X	—	—
-33	63-19-6-2X	—	—	—	63-16-1-2X	—	—
-34	63-19-6-2X	—	—	—	—	—	—
-35	63-19-6-2X	—	—	—	—	—	—
-36	63-19-6-2X	62-452-2	—	5-4-1661	63-16-3-1X	—	47-16-8-2X
-37	63-19-10-2X	63-452-1	—	—	63-16-1-2X	—	—
-38	63-19-6-2X	—	—	—	63-16-9-1X	—	—
-39	63-19-10-2X	63-452-1	—	—	63-16-1-2X	—	—
-40	63-19-6-2X	62-452-3	62-453-5	6-4-2361	63-16-3-2X	—	—

•Rear Bearing Retainer

PARTS LISTED IN THIS CATALOG MAY NO LONGER BE AVAILABLE, USE WITH TRANSMISSION SUPERSEDING LIST.

# MODEL CM60

**SPICER®**



**T210-CM60**

## TABULATED BILLS OF MATERIAL

Tab No.	Used By	For Use With Clutch	CLUTCH HOUSING			Main Drive Gear A-1	Drive Gear Bearing Cap F-2	Case Assembly G-1
			S A E	Assembly No.	Rel. Code Pages 18-19			

### Model CM6052A(Cont'd)

#### 301075

-41	Am. LaFrance	Push Type	1	62-518-32-1X	113	63-35-1*	63-19-17-3-1X**	63-15-1-1X
-42	Challenger Rig	Pull Type	2	62-518-29-1X	—	63-35-1*	63-19-1-1X**	63-15-1-1X
-43	Challenger Rig	Pull Type	2	62-518-29-1X	—	63-35-1*	63-19-1-1X**	63-15-1-1X
-44	S.Madill LTD	Pull Type	2	62-518-29-1X	84	63-35-1*	63-19-1-1X**	63-15-1-1X
-45	Wichita Eng.	Pull Type	2	62-518-29-1X	80	63-35-1*	63-19-1-1X**	63-15-1-1X
-46	Wichita Eng.	Pull Type	2	62-518-27-1X	15	63-35-3*	63-19-1-1X**	63-15-1-1X
-47	Navistar	Push Type	2	62-518-34	—	63-35-14*	63-19-4-1X**	63-15-10-1X***
-48	Navistar	Push Type	2	73-518-3	—	63-35-14*	63-19-4-1X**	63-15-10-1X***
-49	Ford	Pull Type	2	62-518-30-1X	—	63-35-1*	63-19-1-1X**	63-15-5-1X++
-50	Navistar	Pull Type	2	62-518-29-1X	—	63-35-55*	63-19-1-1X**	63-15-10-1X***
-51	Kabus Finland	Pull Type	1	62-518-32-1X	79	63-35-1*	63-19-1-1X**	63-15-1-1X
-52	Gillig	Pull Type	2	62-518-29-1X	68	63-35-1*	63-19-1-1X**	63-15-1-1X
-53	Duplex	Pull Type	2	62-518-29-1X	90	63-35-1*	63-19-1-1X**	63-15-1-1X
-54	Service	Pull Type	1	62-518-32-1X	84	63-35-1*	63-19-1-1X**	63-15-1-1X
-55	Mack	Pull Type	1	62-518-32-1X	—	63-35-1*	63-19-1-1X**	63-15-1-1X
-56	Navistar	Pull Type	2	62-518-29-1X	—	63-35-55*	63-19-1-1X**	63-15-10-2X***
-57	Autocar	Pull Type	2	62-518-29-1X	—	63-35-1*	63-19-1-1X**	63-15-1-1X
-58	GMC	Pull Type	2	62-518-31-1X	—	63-35-1*	63-19-1-1X**	63-15-1-3X

### Model CM6052B

#### 301082

-1	Service	Pull Type	2	62-518-29-1X	—	63-35-1*	63-19-1-1X**	63-15-1-1X
-2	Navistar	Push Type	—	—	—	63-35-14*	63-19-4-1X**	63-15-10-1X***
-3	Ford	Push Type	2	313243	—	63-35-15*	63-19-15-1X**	63-15-5-1X++
-4	Ford	Push Type	—	—	—	63-35-18*	63-19-12-1X**	63-15-11-1X
-5	Ford	Push Type	2	62-518-35-1X	—	63-35-15*	63-19-15-1X**	63-15-5-1X++
-6	Ford	Pull Type	2	62-518-30-1X	—	63-35-1*	63-19-1-1X**	63-15-5-1X++
-7	Tryco	Pull Type	2	62-518-29-1X	59	63-35-1*	63-19-1-1X**	63-15-9-1X
-8	Warner-Swasey	Push Type	2	62-518-27-1X	43	63-35-3*	63-19-23-1X**	63-15-1-1X
-9	G.M.C.	Push Type	—	—	—	63-35-13*	63-19-17-2-1X**	63-15-1-3X
-10	Service	Pull Type	1	62-518-32-1X	84	63-35-1*	63-19-1-1X**	63-15-1-1X
-11	Jack Tidd	Pull Type	1	62-518-32-1X	90	63-35-1*	63-19-1-1X**	63-15-1-1X
-12	G.M.C.	Push Type	—	—	—	63-35-13*	63-19-17-2-1X**	63-15-1-3X
-13	Ward LaFrance	Pull Type	1	62-518-32-1X	94	63-35-1*	63-19-1-1X**	63-15-1-1X
-14	Ford	Push Type	2	313243	—	63-35-15*	63-19-15-1X**	63-15-15-1X
-15	Terra Flex	Push Type	2	62-518-27-1X	39	63-35-3*	63-19-23-1X**	63-15-1-1X
-16	Service	Pull Type	2	62-518-29-1X	94	63-35-1*	63-19-1-1X**	63-15-1-1X
-17§	Service	Push Type	—	—	—	63-35-3*	63-19-23-1X**	63-15-1-1X
-18§	Service	Push Type	—	—	—	63-35-1*	63-19-17-3-1X**	63-15-1-1X
-19	G.M.C.	Push Type	2	312098X	—	63-35-13*	63-19-17-2-1X**	63-15-1-3X
-20	Service	Push Type	2	62-518-27-1X	45	63-35-3*	63-19-23-1X**	63-15-1-1X

§ Short Box

\* These parts have been superseded—see page 6 for Service Part

\*\* These parts have been superseded—see page 7 for Service Part

\*\*\* This part has been superseded by 63-15-1-1X for Service

++ This part has been superseded by 63-15-15-1X for Service

PARTS LISTED IN THIS CATALOG MAY NO LONGER BE AVAILABLE, USE WITH TRANSMISSION SUPERSEDING LIST.



# MODEL CM60

## TABULATED BILLS OF MATERIAL

T210-CM60

Tab No.	Mainshaft Rear Bearing Cap Assembly H-1 (incl. Bushing, Seal)	SPEEDOMETER		End Yoke or Companion Flange Page 16	SHIFTER		
		Drive Gear or Signal Gear B-24	Driven Gear H-7		Housing Ass'y Pages 12-13	Lever & Dome Ass'y Page 17	Remote Control Pages 14-15
<b>Model 6052A (Cont'd)</b>							
<b>301075</b>							
-41	63-19-6-2X	—	—	—	63-16-3-1X	—	47-16-8-2X
-42	63-19-6-2X	—	—	—	63-16-3-1X	47-16-3-1X	—
-43	63-19-6-2X	—	—	—	63-16-1-1X	—	47-16-8-2X
-44	63-19-6-2X	—	—	5-4-1661	63-16-1-1X	—	47-16-8-2X
-45	63-19-6-2X	—	—	—	63-16-3-1X	47-16-3-1X	—
-46	63-19-6-2X	—	—	—	63-16-3-1X	47-16-3-1X	—
-47	63-19-10-2X	63-452-1	—	—	63-16-1-1X	—	—
-48	63-19-8-2X	63-452-1	—	—	63-16-1-2X	—	—
-49	•47-360-1	—	—	—	63-16-3-2X	—	—
-50	63-19-10-2X	63-452-1	—	—	63-16-1-2X	—	—
-51	63-19-6-2X	62-452-3	62-453-5	6-1-2221	63-16-3-1X	—	47-16-8-2X
-52	63-19-6-2X	—	—	5-1-3141	63-16-3-1X	—	47-16-8-5X
-53	63-19-6-2X	62-452-3	62-453-4	—	63-16-3-1X	—	47-16-8-2X
-54	63-19-6-2X	—	—	6-1-2221	63-16-3-1X	47-16-3-1X	—
-55	63-19-6-2X	—	—	—	63-16-1-1X	—	—
-56	63-19-8-2X	63-452-1	—	—	63-16-1-2X	—	—
-57	63-19-6-2X	62-452-3	—	—	63-16-1-1X	—	—
-58	63-19-6-2X	62-452-9	—	—	63-16-9-1X	—	—
<b>Model CM6052B</b>							
<b>301082</b>							
-1	63-19-6-2X	62-452-3	62-453-4	6-4-2361	63-16-1-1X	—	—
-2	63-19-10-2X	63-452-1	—	—	63-16-1-2X	—	—
-3	•47-360-1	—	—	—	63-16-1-1X	—	—
-4	•47-360-1	—	—	—	63-16-1-1X	—	—
-5	•47-360-1	—	—	—	63-16-3-2X	—	—
-6	•47-360-1	—	—	—	63-16-1-1X	—	—
-7	63-19-28-2X	62-452-3	62-453-5	5-1-278X	63-16-1-1X	—	47-16-8-2X
-8	63-19-6-2X	—	—	5-4-1661	63-16-1-1X	—	47-16-8-3X
-9	63-19-28-2X	—	—	—	—	—	—
-10	63-19-6-2X	62-452-3	62-453-4	5-4-1661	63-16-1-1X	47-16-3-3X	—
-11	63-19-6-2X	—	—	5-1-3141	63-16-3-1X	—	47-16-8-2X
-12	63-19-6-2X	—	—	—	—	—	—
-13	63-19-6-2X	62-452-9	62-453-8	6-1-2221	63-16-3-1X	—	47-16-8-2X
-14	—	—	—	—	63-16-1-1X	—	—
-15	63-19-6-2X	—	—	5-1-3141	63-16-1-1X	—	47-16-8-2X
-16	63-19-6-2X	62-452-3	62-453-5	—	63-16-3-1X	47-16-3-1X	—
-17	63-19-6-2X	—	—	—	—	—	—
-18	63-19-6-2X	—	—	—	—	—	—
-19	63-19-6-2X	62-452-9	—	—	63-16-9-1X	—	—
-20	63-19-6-2X	62-452-2	62-452-1	4-1-3781	63-16-3-1X	—	47-16-8-2X

•Rear Bearing Retainer

# MODEL CM60

SPICER®



T210-CM60

## TABULATED BILLS OF MATERIAL

Tab No.	Used By	For Use With Clutch	CLUTCH HOUSING			Main Drive Gear A-1	Drive Gear Bearing Cap F-2	Case Assembly G-1
			S A E	Assembly No.	Rel. Code Pages 18-19			
<b>Model CM6052B (Cont'd)</b>								
<b>301082</b>								
-21	G.M.C.	Push Type	—	—	—	63-35-13*	63-19-17-2-1X**	63-15-1-3X
-22	G.M.C.	Push Type	—	—	—	63-35-13*	63-19-17-2-1X**	63-15-3-1X
-23	Mack	Pull Type	1	62-518-32-1X	46A	63-35-1*	63-19-1-1X**	63-15-1-1X
-24	Navistar	Pull Type	2	62-518-29-1X	—	63-35-1*	63-19-1-1X**	63-15-10-1X***
-25	Servico Unidos	Pull Type	2	62-518-29-1X	84	63-35-1*	63-19-1-1X**	63-15-1-1X
-26	Aetnas	Push Type	2	62-518-27-1X	57	63-35-3*	63-19-23-1X**	63-15-1-1X
-27	Service	Push Type	2	62-518-27-1X	45	63-35-3*	63-19-23-1X**	63-15-1-1X
-28	Hahn	Pull Type	1	62-518-32-1X	90	63-35-1*	63-19-1-1X**	63-15-1-1X
-29	Ford	Pull Type	2	62-518-30-1X	—	63-35-1*	63-19-1-1X**	63-15-5-1X \$\$
-30	Mack	Pull Type	2	62-518-36-1X	—	63-35-1*	63-19-1-1X**	63-15-1-1X
-31	Kenworth	Pull Type	1	62-518-32-1X	64	63-35-1*	63-19-1-1X**	63-15-1-1X
-32	G.M.C.	Pull Type	2	62-518-31-1X	—	63-35-1*	63-19-1-1X**	63-15-1-3X
-33	Navistar	Pull Type	2	62-518-29-1X	—	63-35-55*	63-19-1-1X**	63-15-10-2X***
<b>Model CM6052C</b>								
<b>301083</b>								
-1	Service	Pull Type	2	62-518-29-1X	—	63-35-8*	63-19-1-1X**	63-15-1-1X
-2	Ford	Push Type	—	—	—	63-35-24*	63-19-12-1X**	63-15-11-1X
-3	Navistar	Push Type	—	—	—	63-35-8*	63-19-1-1X**	63-15-10-1X***
-4	Ford	Push Type	2	313243	—	63-35-23*	63-19-15-1X**	63-15-5-1X \$\$
-5	Ford	Push Type	2	62-518-35-1X	—	63-35-23*	63-19-15-1X**	63-15-5-1X \$\$
-6	Am. LaFrance	Push Type	2	62-518-29-1X	113	63-35-8*	63-19-17-3-1X**	63-15-1-1X
-7	G.M.C.	Push Type	2	312098X	—	63-35-29*	63-19-17-2-1X**	63-15-1-3X
-8	G.M.C.	Pull Type	2	62-518-31-1X	—	63-35-8*	63-19-1-1X**	63-15-1-3X
-9	Never released for Production							
-10	Ford	Pull Type	2	62-518-30-1X	—	63-35-8*	63-19-1-1X**	63-15-5-1X \$\$
-11	Omnibuses S.A.	Pull Type	2	62-518-29-1X	90	63-35-8*	63-19-1-1X**	63-15-1-1X
-12	Ford	Push Type	2	313249	—	63-35-23*	63-19-12-1X**	63-15-11-1X
-13	Volvo GM	Push Type	2	62-518-29-1X	—	63-35-8*	63-19-17-3-1X**	63-15-1-1X
-14	Volvo GM	Pull Type	2	62-518-29-1X	—	63-35-8*	63-19-1-1X**	63-15-1-1X
-15§	G.M.C.	Push Type	—	—	—	63-35-29*	63-19-17-2-1X**	63-15-1-3X
-16§	G.M.C.	Pull Type	—	—	—	63-35-8*	63-19-1-1X**	63-15-1-3X
-17	Volvo GM	Pull Type	2	62-518-29-1X	—	63-35-8*	63-19-1-1X**	63-15-1-1X
-18	Mack	Pull Type	1	62-518-32-1X	—	63-35-8*	63-19-1-1X**	63-15-1-1X
-19	Brockway	Pull Type	2	62-518-29-1X	84	63-35-8*	63-19-1-1X**	63-15-1-1X
-20	Navistar	Push Type	2	62-518-34	—	63-35-21*	63-19-4-1X**	63-15-10-1X***
-21	Service	Pull Type	1	62-518-32-1X	84	63-35-8*	63-19-1-1X**	63-15-1-1X
-22	Navistar	Pull Type	1	62-518-32-1X	—	63-35-8*	63-19-1-1X**	63-15-10-1X***
-23	Navistar	Pull Type	2	62-518-29-1X	—	63-35-8*	63-19-1-1X**	63-15-10-1X***
-24§	Service	—	—	—	—	63-35-8*	63-19-17-3-1X**	63-15-1-3X
-25	Service	—	—	—	—	63-35-23*	63-19-15-1X**	63-15-10-1X***

§ Short Box

\* These parts have been superseded—see page 6 for Service Part

\*\* These parts have been superseded—see page 7 for Service Part

\*\*\* This part has been superseded by 63-15-1-1X for Service

+ + This part has been superseded by 63-15-15-1X for Service

PARTS LISTED IN THIS CATALOG MAY NO LONGER BE AVAILABLE, USE WITH TRANSMISSION SUPERSEDING LIST.





# MODEL CM60

## TABULATED BILLS OF MATERIAL

T210-CM60

Tab No.	Mainshaft Rear Bearing Cap Assembly H-1 (incl. Bushing, Seal)	SPEEDOMETER		End Yoke or Companion Flange Page 16	SHIFTER		
		Drive Gear or Signal Gear B-24	Driven Gear H-7		Housing Ass'y Pages 12-13	Lever & Dome Ass'y Page 17	Remote Control Pages 14-15
<b>Model CM6052B (Cont'd)</b>							
<b>301082</b>							
-21	63-19-28-2X	—	—	—	63-16-9-1X	—	—
-22	63-19-6-2X	—	—	—	63-16-9-1X	—	—
-23	63-19-27-2X	—	—	6-4-2361	63-16-3-2X	47-16-5-9X	—
-24	63-19-10-2X	63-452-1	—	—	63-16-1-2X	—	—
-25	63-19-6-2X	62-452-3	62-453-5	6-1-2221	63-16-3-1X	47-16-3-1X	—
-26	63-19-6-2X	62-452-3	62-453-5	4-1-3781	63-16-3-1X	47-16-3-1X	—
-27	63-19-6-2X	—	—	—	63-16-1-1X	—	47-16-8-2X
-28	63-19-6-2X	62-452-3	62-453-5	6-1-2221	63-16-3-1X	—	47-16-8-2X
-29	• 47-360-1	—	—	—	63-16-3-2X	—	—
-30	63-19-6-2X	—	—	—	63-16-1-1X	—	—
-31	63-19-6-2X	62-452-3	62-453-5	6-4-2361	63-16-1-1X	47-16-3-1X	—
-32	63-19-6-2X	62-452-9	—	—	63-16-9-1X	—	—
-33	63-19-8-2X	63-452-1	—	—	63-16-1-2X	—	—
<b>Model CM6052C</b>							
<b>301083</b>							
-1	63-19-6-2X	62-452-3	62-453-4	6-4-2361	63-16-1-1X	—	—
-2	• 47-360-1	—	—	—	63-16-1-1X	—	—
-3	63-19-10-2X	63-452-1	—	—	63-16-1-2X	—	—
-4	• 47-360-1	—	—	—	63-16-1-1X	—	—
-5	• 47-360-1	—	—	—	63-16-3-2X	—	—
-6	63-19-6-2X	—	—	—	63-16-3-1X	—	47-16-8-2X
-7	63-19-6-2X	62-452-9	—	—	63-16-9-1X	—	—
-8	63-19-6-2X	62-452-9	—	—	63-16-9-1X	—	—
-9	Never released for Production		—	—	—	—	—
-10	• 47-360-1	—	—	—	63-16-1-1X	—	—
-11	63-19-27-2X	62-452-2	62-452-1	6-4-2361	63-16-1-1X	—	47-16-8-2X
-12	• 47-360-1	—	—	—	63-16-1-1X	—	—
-13	63-19-6-2X	—	—	—	63-16-3-1X	—	—
-14	63-19-6-2X	—	—	—	63-16-3-1X	—	—
-15	63-19-6-2X	—	—	—	—	—	—
-16	63-19-6-2X	—	—	—	—	—	—
-17	63-19-6-2X	—	—	—	63-16-1-1X	—	—
-18	63-19-6-2X	—	—	—	63-16-1-1X	—	—
-19	63-19-6-2X	62-452-3	62-453-4	—	63-16-1-1X	—	—
-20	63-19-10-2X	63-452-1	—	—	63-16-1-2X	—	—
-21	63-19-6-2X	62-452-3	62-453-4	—	63-16-1-1X	47-16-3-1X	—
-22	63-19-10-2X	63-452-1	—	—	63-16-1-2X	—	—
-23	63-19-10-2X	63-452-1	—	—	63-16-1-2X	—	—
-24	63-19-6-2X	—	—	—	—	—	—
-25	63-19-10-2X	63-452-1	—	—	63-16-1-2X	—	—

•Rear Bearing Retainer

# MODEL CM60

**SPICER®**



**T210-CM60**

## TABULATED BILLS OF MATERIAL

Tab No.	Used By	For Use With Clutch	CLUTCH HOUSING			Main Drive Gear A-1	Drive Gear Bearing Cap F-2	Case Assembly G-1
			S A E	Assembly No.	Rel. Code Pages 18-19			
<b>Model CM6052C (Cont'd)</b>								
<b>301083</b>								
-26	Navistar	Push Type	2	73-518-3	—	63-35-21*	63-19-4-1X**	63-15-10-1X***
-27	G.M.C.	Push Type	—	—	—	63-35-29*	63-19-17-2-1X**	63-15-1-3X
-28	G.M.C.	Push Type	2	312098X	—	63-35-29*	63-19-17-2-1X**	63-15-1-3X
-29	Never released for Production							
-30	Navistar	Push Type	2	62-518-34	—	63-35-21*	63-19-4-1X**	63-15-10-1X***
-31	Geo. Space Co.	Pull Type	1	62-518-32-1X	90	63-35-8*	63-19-1-1X**	63-15-1-1X
-32	Ford	Pull Type	2	62-518-30-1X	—	63-35-8*	63-19-1-1X**	63-15-5-1X++
-33	Navistar	Pull Type	2	62-518-29-1X	—	63-35-54*	63-19-1-1X**	63-15-10-1X***
-34	Navistar	Pull Type	2	62-518-29-1X	—	63-35-54*	63-19-1-1X**	63-15-10-1X***
-35	Am. LaFrance	Push Type	1	62-518-32-1X	113	63-35-8*	63-19-17-3-1X**	63-15-1-1X
<b>Model CM6052D</b>								
<b>301157</b>								
-1	Ford	Pull Type	2	62-518-30-1X	—	63-35-1*	63-19-1-1X**	63-15-5-1X++
-2	Navistar	Pull Type	2	62-518-29-1X	—	63-35-1*	63-19-1-1X**	63-15-10-1X***
-3	Navistar	Pull Type	2	62-518-29-1X	—	63-35-55*	63-19-1-1X**	63-15-10-1X***
<b>Model CM6252A</b>								
<b>301084</b>								
-1	Service	Pull Type	2	62-518-29-1X	—	63-35-10*	63-19-1-1X**	63-15-1-1X
-2	GMC	Push Type	2	312098X	—	63-35-25*	63-19-17-2-1X**	63-15-1-3X
-3	Omnibuses S.A.	Pull Type	2	62-518-29-1X	90	63-35-10*	63-19-1-1X**	63-15-1-1X
-4	Service	Push Type	2	312098X	—	63-35-25*	63-19-17-2-1X**	63-15-1-3X
-5§	Service	Push Type	—	—	—	63-35-10*	63-19-17-3-1X**	63-15-1-3X
-6	Dina	Pull Type	2	62-518-29-1X	81	63-35-10*	63-19-1-1X**	63-15-1-1X
-7	Mack	Pull Type	2	62-518-29-1X	—	63-35-10*	63-19-1-1X**	63-15-1-1X
-8	Am. LaFrance	Push Type	1	62-518-32-1X	113	63-35-10*	63-19-17-3-1X**	63-15-1-1X
<b>Model CM6252B</b>								
<b>301085</b>								
-1	Service	Pull Type	2	62-518-29-1X	—	63-35-12*	63-19-1-1X**	63-15-1-1X
-2	Am. LaFrance	Push Type	1	62-518-32-1X	113	63-35-12*	63-19-17-3-1X**	63-15-1-1X
-3	Gillig	Pull Type	2	62-518-29-1X	91	63-35-12*	63-19-1-1X**	63-15-1-1X
-4	Ford	Pull Type	2	62-518-30-1X	—	63-35-12*	63-19-1-1X**	63-15-5-1X++
-5	Hendrickson	Pull Type	2	62-518-29-1X	84	63-35-12*	63-19-1-1X**	63-15-1-1X
-6	Hahn Motors	Pull Type	1	62-518-32-1X	90	63-35-12*	63-19-1-1X**	63-15-1-1X
-7	Clev. Trencher	Pull Type	1	62-518-32-1X	59	63-35-12*	63-19-1-1X**	63-15-1-1X
-8	Clev. Trencher	Pull Type	1	62-518-32-1X	59	63-35-12*	63-19-1-1X**	63-15-1-1X
-9	Warner-Swasey	Pull Type	2	62-518-29-1X	90	63-35-12*	63-19-1-1X**	63-15-1-1X
-10	Mack	Pull Type	1	62-518-32-1X	46A	63-35-12*	63-19-1-1X**	63-15-1-1X

§ Short Box

\* These parts have been superseded—see page 6 for Service Part

\*\* These parts have been superseded—see page 7 for Service Part

\*\*\* This part has been superseded by 63-15-1-1X for Service

++ This part has been superseded by 63-15-15-1X for Service

PARTS LISTED IN THIS CATALOG MAY NO LONGER BE AVAILABLE, USE WITH TRANSMISSION SUPERSEDING LIST.



# MODEL CM60

## TABULATED BILLS OF MATERIAL

T210-CM60

Tab No.	Mainshaft Rear Bearing Cap Assembly H-1 (incl. Bushing, Seal)	SPEEDOMETER		End Yoke or Companion Flange Page 16	SHIFTER		
		Drive Gear or Signal Gear B-24	Driven Gear H-7		Housing Ass'y Pages 12-13	Lever & Dome Ass'y Page 17	Remote Control Pages 14-15
<b>Model CM6052C (Cont'd)</b>							
<b>301083</b>							
-26	63-19-10-2X	63-452-1	—	—	63-16-1-2X	—	—
-27	63-19-6-2X	—	—	—	63-16-9-1X	—	—
-28	63-19-28-2X	62-452-9	—	—	63-16-9-1X	—	—
-29	Never released for Production						
-30	63-19-8-2X	63-452-1	—	—	63-16-1-2X	—	—
-31	63-19-6-2X	—	—	—	63-16-1-1X	—	—
-32	—	—	—	—	63-16-3-2X	—	—
-33	63-19-10-2X	63-452-1	—	—	63-16-1-2X	—	—
-34	63-19-8-2X	63-452-1	—	—	63-16-1-2X	—	—
-35	63-19-6-2X	—	—	—	63-16-3-1X	—	47-16-8-2X
<b>Model CM6052D</b>							
<b>301157</b>							
-1	• 47-360-1	—	—	—	63-16-1-1X	—	—
-2	63-19-10-2X	63-452-1	—	—	63-16-1-2X	—	—
-3	63-19-10-2X	63-452-1	—	—	63-16-1-2X	—	—
<b>Model CM6252A</b>							
<b>301084</b>							
-1	63-19-6-2X	62-452-3	62-453-4	6-4-2361	63-16-1-1X	—	—
-2	63-19-6-2X	62-452-9	—	—	63-16-9-1X	—	—
-3	63-19-6-2X	62-452-2	62-452-1	6-4-2361	63-16-3-1X	—	47-16-8-2X
-4	63-19-28-2X	62-452-9	62-453-8	6-1-2801X	63-16-1-1X	—	—
-5	63-16-6-2X	—	—	—	—	—	—
-6	63-19-6-2X	62-452-13	62-453-10	6-4-2361	63-16-3-1X	—	47-16-9-2X
-7	63-19-6-2X	—	—	—	63-16-1-1X	—	—
-8	63-19-6-2X	—	—	—	63-16-3-1X	—	47-16-8-2X
<b>Model CM6252B</b>							
<b>301085</b>							
-1	63-19-6-2X	62-452-3	62-453-4	6-4-2361	63-16-1-1X	—	—
-2	63-19-6-2X	—	—	—	63-16-3-1X	—	47-16-8-2X
-3	63-19-6-2X	—	—	5-1-3141	63-16-1-1X	—	47-16-8-4X
-4	• 47-360-1	—	—	—	—	—	—
-5	63-19-6-2X	62-452-2	—	—	63-16-1-1X	—	47-16-8-2X
-6	63-19-6-2X	62-452-3	62-453-5	6-1-2221	63-16-3-1X	—	47-16-8-2X
-7	63-19-27-2X	—	—	5-1-3141	63-16-3-4X	—	47-16-8-2X
-8	63-19-27-2X	—	—	5-1-3141	63-16-3-4X	—	47-16-8-2X
-9	63-19-6-2X	62-452-3	62-453-4	—	63-16-3-1X	—	47-16-8-2X
-10	63-19-27-2X	—	—	5-1-3141	63-16-1-1X	—	47-16-8-4X

•Rear Bearing Retainer

# MODEL CM60

**SPICER®**



**T210-CM60**

## TABULATED BILLS OF MATERIAL

Tab No.	Used By	For Use With Clutch	CLUTCH HOUSING			Main Drive Gear A-1	Drive Gear Bearing Cap F-2	Case Assembly G-1
			S A E	Assembly No.	Rel. Code Pages 18-19			
<b>Model CM6252B (Cont'd)</b>								
<b>301085</b>								
-11	Mack	Pull Type	1	62-518-32-1X	46A	63-35-12*	63-19-1-1X**	63-15-1-1X
-12	Hahn Motors	Pull Type	2	62-518-29-1X	90	63-35-12*	63-19-1-1X**	63-15-1-1X
-13	Hahn Motors	Pull Type	2	62-518-29-1X	90	63-35-12*	63-19-1-1X**	63-15-1-1X
-14	Hahn Motors	Pull Type	2	62-518-29-1X	90	63-35-12*	63-19-1-1X**	63-15-1-1X
-15	FWD	Pull Type	1	62-518-32-1X	46A	63-35-12*	63-19-1-1X**	63-15-1-1X
-16	Spartan Motors	Pull Type	2	62-518-29-1X	90	63-35-12*	63-19-1-1X**	63-15-1-1X
-17	Mack	Pull Type	1	62-518-32-1X	46A	63-35-12*	63-19-1-1X**	63-15-1-1X
-18	Mack	Pull Type	1	62-518-32-1X	46A	63-35-12*	63-19-1-1X**	63-15-1-1X
-19	Mack	Pull Type	1	62-518-32-1X	46A	63-35-12*	63-19-1-1X**	63-15-1-1X
-20	Crown Coach	Pull Type	1	62-518-32-1X	86	63-35-12*	63-19-1-1X**	63-15-1-1X
-21§	Service	—	—	—	—	63-35-12*	63-19-17-3-1X**	63-15-1-1X
-22	Service	Pull Type	1	62-518-32-1X	84	63-35-12*	63-19-1-1X**	63-15-1-1X
-23	Mack	Pull Type	1	62-518-32-1X	46A	63-35-12*	63-19-1-1X**	63-15-1-1X
-24	Service	Pull Type	1	62-518-32-1X	94	63-35-12*	63-19-1-1X**	63-15-1-1X
-25	Mack	Pull Type	1	62-518-32-1X	46A	63-35-12*	63-19-1-1X**	63-15-1-1X
-26	Pem Fab	Pull Type	1	62-518-32-1X	90	63-35-12*	63-19-1-1X**	63-15-1-1X
-27	Am. LaFrance	Push Type	2	62-518-29-1X	113	63-35-12*	63-19-17-3-1X**	63-15-1-1X
-28	Mack	Pull Type	1	62-518-32-1X	46A	63-35-12*	63-19-1-1X**	63-15-1-1X
-29	Volvo GM	Pull Type	2	62-518-29-1X	—	63-35-12*	63-19-1-1X**	63-15-1-1X
<b>Model 6253A</b>								
<b>301086</b>								
-1	Service	Pull Type	2	62-518-29-1X	—	63-35-10*	63-19-1-1X**	63-15-1-1X
-2	GMC	Push Type	2	312098X	—	63-35-25*	63-19-17-2-1X**	63-15-1-3X
-3	GMC	Pull Type	2	62-518-31-1X	—	63-35-10*	63-19-1-1X**	63-15-1-3X
-4	Never released for Production							
-5	Madill	Pull Type	2	62-518-29-1X	84	63-35-10*	63-19-1-1X**	63-15-1-1X
-6	Ford	Pull Type	2	62-518-30-1X	—	63-35-10*	63-19-1-1X**	63-15-5-1X++
-7	Ward LaFrance	Pull Type	1	62-518-32-1X	94	63-35-10*	63-19-1-1X**	63-15-1-1X
-8§	GMC	—	—	—	—	63-35-25*	63-19-17-2-1X**	63-15-1-3X
-9	Navistar	Pull Type	1	62-518-32-1X	—	63-35-10*	63-19-1-1X**	63-15-10-1X***
-10§	GMC	—	—	—	—	63-35-10*	63-19-1-1X**	63-15-1-3X
-11	FWD	Pull Type	1	62-518-32-1X	90	63-35-10*	63-19-1-1X**	63-15-1-1X
-12	Warner-Swasey	Push Type	2	62-518-29-1X	46	63-35-10*	63-19-17-3-1X**	63-15-1-1X
-13§	Service	—	—	—	—	63-35-10*	63-19-17-3-1X**	63-15-1-1X
-14	Navistar	Pull Type	1	62-518-32-1X	—	63-35-10*	63-19-1-1X**	63-15-10-1X***
-15	GMC	—	—	—	—	63-35-25*	63-19-17-2-1X**	63-15-1-3X
-16	Never released for Production							
-17	Mack	Pull Type	1	62-518-32-1X	46A	63-35-10*	63-19-1-1X**	63-15-1-1X
-18	Am. LaFrance	Push Type	2	62-518-29-1X	113	63-35-10*	63-19-17-3-1X**	63-15-1-1X
-19	Mack	Pull Type	2	62-518-29-1X	—	63-35-10*	63-19-1-1X**	63-15-1-1X
-20	Service	Push Type	2	62-518-29-1X	46	63-35-10*	63-19-17-3-1X**	63-15-1-1X
-21	Hahn Motors	Pull Type	1	62-518-32-1X	90	63-35-10*	63-19-1-1X**	63-15-1-1X

§ Short Box

\* These parts have been superseded—see page 6 for Service Part

\*\* These parts have been superseded—see page 7 for Service Part

\*\*\* This part has been superseded by 63-15-1-1X for Service

+ + This part has been superseded by 63-15-15-1X for Service.

PARTS LISTED IN THIS CATALOG MAY NO LONGER BE AVAILABLE, USE WITH TRANSMISSION SUPERSEDING LIST.



Tab No.	Mainshaft Rear Bearing Cap Assembly H-1 (incl. Bushing, Seal)	SPEEDOMETER			End Yoke or Companion Flange Page 16	SHIFTER		
		Drive Gear or Signal Gear B-24	Driven Gear H-7			Housing Ass'y Pages 12-13	Lever & Dome Ass'y Page 17	Remote Control Pages 14-15
<b>Model CM6252B (Cont'd)</b>								
<b>301085</b>								
-11	63-19-27-2X	—	—	6-1-2221	63-16-1-1X	—	47-16-8-4X	
-12	63-19-6-2X	62-452-3	62-453-5	5-1-3141	63-16-3-1X	—	47-16-8-2X	
-13	63-19-6-2X	62-452-3	62-453-4	5-1-3141	63-16-3-1X	—	47-16-8-2X	
-14	63-19-6-2X	62-452-3	62-453-5	6-1-2221	63-16-3-1X	—	47-16-8-2X	
-15	63-19-6-2X	—	—	—	63-16-1-1X	—	—	
-16	63-19-6-2X	62-452-3	62-453-5	6-1-2221	63-16-1-1X	—	47-16-8-2X	
-17	63-19-27-2X	—	—	5-4-1661	63-16-3-2X	47-16-5-9X	—	
-18	63-19-27-2X	—	—	5-4-1661	63-16-1-1X	—	47-16-8-2X	
-19	63-19-27-2X	—	—	6-4-2361	63-16-3-2X	47-16-5-9X	—	
-20	63-19-6-2X	62-452-3	62-453-5	6-1-2221	63-16-1-1X	—	311656-11X	
-21	63-19-6-2X	—	—	—	—	—	—	
-22	63-19-6-2X	62-452-3	62-453-5	6-4-2361	63-16-1-1X	—	47-16-8-2X	
-23	63-19-27-2X	—	—	5-4-1661	63-16-1-1X	—	47-16-8-4X	
-24	63-19-6-2X	—	—	5-1-3141	63-16-3-1X	—	47-16-8-2X	
-25	63-19-27-2X	—	—	6-4-2361	63-16-1-1X	—	47-16-8-4X	
-26	63-19-6-2X	—	—	—	63-16-3-1X	—	47-16-8-2X	
-27	63-19-6-2X	—	—	—	63-16-3-1X	—	47-16-8-2X	
-28	63-19-27-2X	—	—	6-4-2361	63-16-3-1X	—	47-16-8-2X	
-29	63-19-6-2X	—	—	—	63-16-1-1X	—	—	
<b>Model 6253A</b>								
<b>301086</b>								
-1	63-19-6-2X	62-452-3	62-453-4	6-4-2361	63-16-1-1X	—	—	
-2	63-19-6-2X	62-452-9	—	—	63-16-9-1X	—	—	
-3	63-19-6-2X	62-452-9	—	—	63-16-9-1X	—	—	
-4	Never released for Production							
-5	63-19-6-2X	—	—	5-4-1661	63-16-1-1X	—	47-16-8-2X	
-6	• 47-360-1	—	—	—	63-16-1-1X	—	—	
-7	63-19-6-2X	62-452-9	62-453-8	6-1-2221	63-16-3-1X	—	47-16-8-2X	
-8	63-19-6-2X	—	—	—	—	—	—	
-9	63-19-10-2X	63-452-1	—	—	63-16-1-2X	—	—	
-10	63-19-6-2X	—	—	—	—	—	—	
-11	63-19-6-2X	—	—	—	63-16-1-1X	—	—	
-12	63-19-6-2X	—	—	5-4-1661	63-16-1-1X	—	47-16-8-3X	
-13	63-19-6-2X	—	—	—	—	—	—	
-14	63-19-10-2X	63-452-1	—	—	63-16-3-6X	—	—	
-15	63-19-6-2X	—	—	—	63-16-9-1X	—	—	
-16	Never released for Production							
-17	63-19-27-2X	—	—	6-1-2221	63-16-1-1X	—	47-16-8-4X	
-18	63-19-6-2X	—	—	—	63-16-3-1X	—	47-16-8-2X	
-19	63-19-6-2X	—	—	—	63-16-1-1X	—	—	
-20	63-19-6-2X	—	—	5-1-3151	63-16-1-1X	47-16-3-1X	—	
-21	63-19-6-2X	62-452-3	62-453-5	6-1-2221	63-16-3-1X	—	47-16-8-2X	

•Rear Bearing Retainer

# MODEL CM60

SPICER®



T210-CM60

## TABULATED BILLS OF MATERIAL

Tab No.	Used By	For Use With Clutch	CLUTCH HOUSING			Main Drive Gear A-1	Drive Gear Bearing Cap F-2	Case Assembly G-1
			S A E	Assembly No.	Rel. Code Pages 18-19			
<b>Model CM6253B</b>								
<b>301087</b>								
-1	Service	Pull Type	2	62-518-29-1X	—	63-35-12*	63-19-1-1X**	63-15-1-1X
-2	Ward LaFrance	Push Type	1	62-518-32-1X	46	63-35-12*	63-19-17-3-1X**	63-15-1-1X
-3	Am. LaFrance	Push Type	1	62-518-32-1X	113	63-35-12*	63-19-17-3-1X**	63-15-1-1X
-4	Hendrickson	Pull Type	2	62-518-29-1X	84	63-35-12*	63-19-1-1X**	63-15-1-1X
-5	FWD	Pull Type	1	62-518-32-1X	90	63-35-12*	63-19-1-1X**	63-15-1-1X
-6	FWD	Pull Type	2	62-518-29-1X	90	63-35-12*	63-19-1-1X**	63-15-1-1X
-7	Hahn Motors	Pull Type	1	62-518-32-1X	90	63-35-12*	63-19-1-1X**	63-15-1-1X
-8	Peter Pirsch	Pull Type	2	62-518-29-1X	83	63-35-12*	63-19-1-1X**	63-15-1-1X
-9	Service	Pull Type	2	62-518-29-1X	92A	63-35-12*	63-19-1-1X**	63-15-5-1X++
-10	Hahn Motors	Pull Type	2	62-518-29-1X	90	63-35-12*	63-19-1-1X**	63-15-1-1X
-11	Hahn Motors	Pull Type	2	62-518-29-1X	90	63-35-12*	63-19-1-1X**	63-15-1-1X
-12	Never released for Production							
-13	Service	Pull Type	2	62-518-29-1X	90	63-35-12*	63-19-1-1X**	63-15-1-1X
-14	Hahn Motors	Push Type	1	62-518-32-1X	—	63-35-12*	63-19-17-3-1X**	63-15-1-1X
-15	Never released for Production							
-16	Ward LaFrance	Pull Type	1	62-518-32-1X	94	63-35-12*	63-19-1-1X**	63-15-1-1X
-17	Warner-Swasey	Pull Type	2	62-518-29-1X	90	63-35-12*	63-19-1-1X**	63-15-1-1X
-18	Warner-Swasey	Push Type	2	62-518-29-1X	46	63-35-12*	63-19-17-3-1X**	63-15-1-1X
-19	Warner-Swasey	Push Type	2	62-518-29-1X	46	63-35-12*	63-19-17-3-1X**	63-15-1-1X
<b>Model CM6052A</b>								
<b>301253</b>								
-1	Service	Pull Type	2	62-518-29-1X	—	63-35-34-1X	63-19-36-1X	63-15-1-1X
-2	Service	Pull Type	2	62-518-29-1X	—	63-35-34-1X	63-19-36-1X	63-15-1-1X
-3	Service	Push Type	2	62-518-27-1X	—	63-35-45-1X	63-19-31-1X	63-15-1-1X
-4	Ford	Push Type	—	—	—	63-35-38-1X	63-19-20-1X	63-15-11-1X
-5	Ford	Push Type	2	313243	—	63-35-37-1X	63-19-21-1X	63-15-5-1X++
-6§	Navistar	Push Type	—	—	—	63-35-48-1X	63-19-22-1X	63-15-10-1X***
-7	Never released for Production							
-8	Harnishfeger	Push Type	2	62-518-29-1X	42	63-35-34-1X	63-19-30-3-1X	63-15-1-1X
-9	Ford	Pull Type	2	62-518-30-1X	—	63-35-34-1X	63-19-36-1X	63-15-1-1X
-10	AM General	Pull Type	2	62-518-29-1X	94	63-35-34-1X	63-19-36-1X	63-15-1-1X
-11	Oshkosh	Push Type	2	62-518-29-1X	40	63-35-34-1X	63-19-30-3-1X	63-15-1-1X
-12	Mack	Pull Type	2	62-518-36-1X	—	63-35-34-1X	63-19-36-1X	63-15-1-1X
-13	Never released for Production							
-14	Mack	Pull Type	2	62-518-29-1X	—	63-35-34-1X	63-19-36-1X	63-15-1-1X
-15	Volvo GM	Pull Type	2	62-518-29-1X	—	63-35-34-1X	63-19-36-1X	63-15-1-1X
-16	Volvo GM	Pull Type	2	62-518-29-1X	—	63-35-34-1X	63-19-36-1X	63-15-1-1X
-17	Gardner Denver	Pull Type	2	62-518-29-1X	84	63-35-34-1X	63-19-36-1X	63-15-1-1X
-18§	GMC	Push Type	—	—	—	63-35-34-1X	63-19-30-3-1X	63-15-1-1X
-19	GMC	Push Type	2	312098X	—	63-35-47-1X	63-19-30-2-1X	63-15-1-1X
-20	Volvo GM	Push Type	2	62-518-29-1X	—	63-35-34-1X	63-19-30-3-1X	63-15-1-1X

§ Short Box

\* These parts have been superseded—see page 6 for Service Part

\*\* These parts have been superseded—see page 7 for Service Part

\*\*\* This part has been superseded by 63-15-1-1X for Service

++ This part has been superseded by 63-15-15-1X for Service

PARTS LISTED IN THIS CATALOG MAY NO LONGER BE AVAILABLE, USE WITH TRANSMISSION SUPERSEDING LIST.



# MODEL CM60

## TABULATED BILLS OF MATERIAL

T210-CM60

Tab No.	Mainshaft Rear Bearing Cap Assembly H-1 (incl. Bushing, Seal)	SPEEDOMETER		End Yoke or Companion Flange Page 16	SHIFTER		
		Drive Gear or Signal Gear B-24	Driven Gear H-7		Housing Ass'y Pages 12-13	Lever & Dome Ass'y Page 17	Remote Control Pages 14-15
<b>Model CM6253B</b>							
<b>301087</b>							
-1	63-19-6-2X	62-452-3	62-453-4	6-4-2361	63-16-1-1X	—	—
-2	63-19-6-2X	—	—	—	63-16-3-1X	—	47-16-8-2X
-3	63-19-6-2X	—	—	—	63-16-3-1X	—	47-16-8-2X
-4	63-19-6-2X	62-452-2	—	—	63-16-1-1X	—	47-16-8-2X
-5	63-19-6-2X	—	—	—	63-16-1-1X	—	—
-6	63-19-6-2X	—	—	—	63-16-1-2X	—	—
-7	63-19-6-2X	62-452-3	62-453-5	6-1-2221	63-16-3-1X	—	47-16-8-2X
-8	63-19-27-2X	62-452-3	62-453-3	6-1-2221	63-16-3-1X	—	47-16-8-5X
-9	63-19-6-2X	—	—	—	63-16-3-1X	—	47-16-8-2X
-10	63-19-6-2X	62-452-2	62-452-1	5-1-3141	63-16-3-1X	—	47-16-8-2X
-11	63-19-6-2X	62-452-3	62-453-4	6-1-2221	63-16-3-1X	—	47-16-8-2X
-12	Never released for Production						
-13	63-19-6-2X	62-452-3	62-453-4	6-1-2221	63-16-1-1X	—	47-16-8-2X
-14	63-19-6-2X	62-452-3	62-453-4	6-1-2221	63-16-3-1X	—	47-16-8-2X
-15	Never released for Production						
-16	63-19-6-2X	—	—	6-1-2221	63-16-3-1X	—	47-16-8-2X
-17	63-19-6-2X	—	—	—	63-16-3-1X	—	47-16-8-2X
-18	63-19-6-2X	—	—	5-4-1661	63-16-1-1X	—	47-16-8-3X
-19	63-19-6-2X	—	—	5-4-1661	63-16-1-1X	—	—
<b>Model CM6052A</b>							
<b>301253</b>							
-1	63-19-6-2X	62-452-3	62-453-4	6-4-2361	63-16-1-1X	—	—
-2	63-19-6-2X	62-452-3	62-453-4	6-4-2361	63-16-3-1X	—	—
-3	63-19-6-2X	62-452-3	62-453-4	6-4-2361	63-16-3-1X	—	—
-4	•47-360-1	—	—	—	63-16-1-1X	—	—
-5	63-19-6-2X	—	—	—	—	—	—
-6	63-19-10-2X	63-452-1	—	—	—	—	—
-7	Never released for Production						
-8	63-19-6-2X	—	—	5-4-1661	63-16-3-5X	—	47-16-8-2X
-9	•47-360-1	—	—	—	63-16-1-1X	—	47-16-9-2X
-10	63-19-6-2X	62-452-9	62-453-8	6-5-1-2121	63-16-3-1X	—	47-16-9-2X
-11	63-19-6-2X	62-452-3	62-453-5	5-4-1661	63-16-3-2X	—	47-16-8-2X
-12	63-19-6-2X	—	—	—	63-16-1-1X	—	—
-13	Never released for Production						
-14	63-19-6-2X	—	—	—	63-16-1-1X	—	—
-15	63-19-6-2X	—	—	—	63-16-3-1X	—	—
-16	63-19-6-2X	—	—	—	63-16-1-1X	—	—
-17	63-19-6-2X	—	—	6-1-2221	63-16-3-1X	47-16-3-1X	—
-18	63-19-6-2X	—	—	—	—	—	—
-19	63-19-6-2X	62-452-9	—	—	63-16-9-1X	—	—
-20	63-19-6-2X	—	—	—	63-16-3-1X	—	—

•Rear Bearing Retainer

# MODEL CM60

SPICER®



T210-CM60

## TABULATED BILLS OF MATERIAL

Tab No.	Used By	For Use With Clutch	CLUTCH HOUSING			Main Drive Gear A-1	Drive Gear Bearing Cap F-2	Case Assembly G-1
			S A E	Assembly No.	Rel. Code Pages 18-19			
<b>Model CM6052A (Cont'd)</b>								
<b>301253</b>								
-21§	GMC	Push Type	—	—	—	63-35-47-1X	63-19-30-2-1X	63-15-1-1X
-22	Kenworth	Pull Type	2	62-518-29-1X	84	63-35-34-1X	63-19-36-1X	63-15-1-1X
-23	Ford	Push Type	2	313243	—	63-35-37-1X	63-19-21-1X	63-15-15-1X
-24	Spartan Motors	Pull Type	2	62-518-29-1X	88	63-35-34-1X	63-19-36-1X	63-15-1-1X
-25	Navistar	Pull Type	2	62-518-29-1X	—	63-35-34-1X	63-19-36-1X	63-15-1-1X
-26	DSD	Pull Type	2	62-518-29-1X	80	63-35-34-1X	63-19-36-1X	63-15-1-1X
-27	DSD	Pull Type	1	62-518-32-1X	59	63-35-34-1X	63-19-36-1X	63-15-1-1X
-28	Cooper Mfg.	Pull Type	1	62-518-32-1X	80	63-35-34-1X	63-19-36-1X	63-15-1-1X
-29	Cooper Mfg.	Pull Type	1	62-518-32-1X	80	63-35-34-1X	63-19-36-1X	63-15-1-1X
-30	Navistar	Pull Type	2	62-518-29-1X	—	63-35-34-1X	63-19-36-1X	63-15-1-1X
-31	Spartan Motors	Push Type	2	62-518-29-1X	22	63-35-34-1X	63-19-30-3-1X	63-15-1-1X
-32	GMC	Push Type	2	312098X	—	63-35-47-1X	63-19-30-2-1X	63-15-1-1X
-33	DWT	Pull Type	—	—	—	63-35-34-1X	63-19-36-1X	63-15-1-1X
-34§	DWT	Push Type	—	—	—	63-35-45-1X	63-19-31-1X	63-15-1-1X
-35§	DWT	Push Type	—	—	—	63-35-34-1X	63-19-30-3-1X	63-15-1-1X
-36	Hendrickson	Pull Type	2	62-518-29-1X	84	63-35-34-1X	63-19-36-1X	63-15-1-1X
-37§	Navistar	Pull Type	—	—	—	63-35-34-1X	63-19-36-1X	63-15-1-1X
-38	GMC	Push Type	—	—	—	63-35-34-1X	63-19-30-3-1X	63-15-1-1X
-39	Navistar	Push Type	2	73-518-3	—	63-35-48-1X	63-19-22-1X	63-15-1-1X
-40	Scot Truck Ltd.	Pull Type	1	62-518-32-1X	—	63-35-34-1X	63-19-36-1X	63-15-1-1X
-41	Am. LaFrance	Push Type	1	62-518-32-1X	113	63-35-34-1X	63-19-30-3-1X	63-15-1-1X
-42	Cooper Mfg.	Pull Type	2	62-518-29-1X	—	63-35-34-1X	63-19-36-1X	63-15-1-1X
-43	Cooper Mfg.	Pull Type	2	62-518-29-1X	—	63-35-34-1X	63-19-36-1X	63-15-1-1X
-44	Madill Ltd.	Pull Type	2	62-518-29-1X	84	63-35-34-1X	63-19-36-1X	63-15-1-1X
-45	Wichita Eng.	Pull Type	2	62-518-29-1X	80	63-35-34-1X	63-19-36-1X	63-15-1-1X
-46	Wichita Eng.	Pull Type	2	62-518-27-1X	15	63-35-45-1X	63-19-36-1X	63-15-1-1X
-47	Navistar	Push Type	2	62-518-34	—	63-35-48-1X	63-19-22-1X	63-15-1-1X
-48	Navistar	Push Type	2	73-518-3	—	63-35-48-1X	63-19-22-1X	63-15-1-1X
-49	Never released for Production							
-50	Navistar	Pull Type	2	62-518-29-1X	—	63-35-57-1X	63-19-36-1X	63-15-1-1X
-51	Kabus oy Finld.	Pull Type	1	62-518-32-1X	79	63-35-34-1X	63-19-36-1X	63-15-1-1X
-52	Gillig	Pull Type	2	62-518-29-1X	68	63-35-34-1X	63-19-36-1X	63-15-1-1X
-53	Duplex Div.	Pull Type	2	62-518-29-1X	90	63-35-34-1X	63-19-36-1X	63-15-1-1X
-54	Gardner Denver	Pull Type	1	62-518-32-1X	84	63-35-34-1X	63-19-36-1X	63-15-1-1X
-55	Mack	Pull Type	1	62-518-32-1X	—	63-35-34-1X	63-19-36-1X	63-15-1-1X
-56	Navistar	Pull Type	2	62-518-29-1X	—	63-35-57-1X	63-19-36-1X	63-15-1-1X
-57	Autocar	Pull Type	2	62-518-29-1X	—	63-35-34-1X	63-19-36-1X	63-15-1-1X
-58	GMC	Pull Type	2	62-518-31-1X	—	63-35-34-1X	63-19-36-1X	63-15-1-1X
-59	Cooper Mfg.	Pull Type	2	62-518-29-1X	84	63-35-34-1X	63-19-36-1X	63-15-1-1X
-60	Cooper Mfg.	Pull Type	1	62-518-32-1X	84	63-35-34-1X	63-19-36-1X	63-15-1-1X

§ Short Box

PARTS LISTED IN THIS CATALOG MAY NO LONGER BE AVAILABLE, USE WITH TRANSMISSION SUPERSEDING LIST.





Tab No.	Mainshaft Rear Bearing Cap Assembly H-1 (incl. Bushing, Seal)	SPEEDOMETER		End Yoke or Companion Flange Page 16	SHIFTER		
		Drive Gear or Signal Gear B-24	Driven Gear H-7		Housing Ass'y Pages 12-13	Lever & Dome Ass'y Page 17	Remote Control Pages 14-15
<b>Model CM6052A (Cont'd)</b>							
<b>301253</b>							
-21	63-19-6-2X	—	—	—	—	—	—
-22	63-19-6-2X	62-452-3	62-453-5	6-4-2361	63-16-1-1X	47-16-3-3X	—
-23	•47-360-1	—	—	—	63-16-1-1X	—	—
-24	63-19-6-2X	62-452-3	62-453-5	5-1-3141	63-16-1-1X	—	47-16-8-2X
-25	63-19-8-2X	63-452-1	—	—	63-16-1-2X	—	—
-26	63-19-6-2X	—	—	4-1-3781	63-16-3-1X	47-16-3-1X	—
-27	63-19-6-2X	—	—	5-1-3141	63-16-3-1X	—	47-16-8-2X
-28	63-19-6-2X	62-452-3	62-453-4	6-1-2221	63-16-3-1X	—	—
-29	63-19-6-2X	62-452-3	62-453-4	6-1-2221	63-16-3-1X	47-16-3-1X	—
-30	63-19-10-2X	63-452-1	—	—	63-16-1-2X	—	—
-31	63-19-6-2X	62-452-3	62-453-5	5-1-3141	63-16-1-1X	—	47-16-8-2X
-32	63-19-6-2X	62-452-9	—	5-4-1661	63-16-9-1X	—	—
-33	63-19-6-2X	—	—	—	63-16-1-2X	—	—
-34	63-19-6-2X	—	—	—	—	—	—
-35	63-19-6-2X	—	—	—	—	—	—
-36	63-19-6-2X	62-452-2	—	5-4-1661	63-16-3-1X	—	47-16-8-2X
-37	63-19-10-2X	63-452-1	—	—	63-16-1-2X	—	—
-38	63-19-6-2X	—	—	—	63-16-9-1X	—	—
-39	63-19-10-2X	63-452-1	—	—	63-16-1-2X	—	—
-40	63-19-6-2X	62-452-3	62-453-5	6-4-2361	63-16-3-2X	—	—
-41	63-19-6-2X	—	—	—	63-16-3-1X	—	47-16-8-2X
-42	63-19-6-2X	—	—	—	63-16-1-1X	47-16-3-1X	—
-43	63-19-6-2X	—	—	—	63-16-1-1X	—	47-16-8-2X
-44	63-19-6-2X	—	—	5-4-1661	63-16-1-1X	—	47-16-8-2X
-45	63-19-6-2X	—	—	—	63-16-3-1X	47-16-3-1X	—
-46	63-19-6-2X	—	—	—	63-16-3-1X	47-16-3-1X	—
-47	63-19-10-2X	63-452-1	—	—	63-16-1-2X	—	—
-48	63-19-8-2X	63-452-1	—	—	63-16-1-2X	—	—
-49	Never released for Production						
-50	63-19-10-2X	63-452-1	—	—	63-16-1-2X	—	—
-51	63-19-6-2X	62-452-3	62-453-5	6-1-2221	63-16-3-1X	—	47-16-8-2X
-52	63-19-6-2X	—	—	—	63-16-3-1X	—	47-16-8-5X
-53	63-19-6-2X	62-452-3	62-453-4	—	63-16-3-1X	—	47-16-8-2X
-54	63-19-6-2X	—	—	6-1-2221	63-16-3-1X	47-16-3-1X	—
-55	63-19-6-2X	—	—	—	63-16-1-1X	—	—
-56	63-19-8-2X	63-452-1	—	—	63-16-1-2X	—	—
-57	63-19-6-2X	62-452-3	—	—	63-16-1-1X	—	—
-58	63-19-6-2X	62-452-9	—	—	63-16-9-1X	—	—
-59	63-19-6-2X	—	—	6-1-2221	63-16-1-1X	47-16-3-1X	—
-60	63-16-6-2X	—	—	6-1-2221	63-16-1-1X	47-16-3-1X	—

•Rear Bearing Retainer

# MODEL CM60

**SPICER®**



**T210-CM60**

## TABULATED BILLS OF MATERIAL

Tab No.	Used By	For Use With Clutch	CLUTCH HOUSING			Main Drive Gear A-1	Drive Gear Bearing Cap F-2	Case Assembly G-1
			S A E	Assembly No.	Rel. Code Pages 18-19			
<b>Model CM6052A (Cont'd)</b>								
<b>301253</b>								
-61	Ford	Push Type	—	—	—	63-35-38-1X	63-19-20-1X	63-15-11-1X
-62	Ford	Push Type	—	—	—	63-35-38-1X	63-19-20-1X	63-15-11-1X
-63	Ford	Push Type	2	313243	—	63-35-37-1X	63-19-21-1X	63-15-5-1X++
-64	Ford	Push Type	2	313243	—	63-35-37-1X	63-19-21-1X	63-15-5-1X++
-65	Gradall	Push Type	2	62-518-29-1X	39	63-35-34-1X	63-19-30-3-1X	63-15-1-1X
-66	Bissinger/Stein	Pull Type	2	62-518-29-1X	80	63-35-34-1X	63-19-36-1X	63-15-1-1X
-67	Ford	Pull Type	2	62-518-30-1X	—	63-35-34-1X	63-19-36-1X	63-15-5-1X++
-68	Ford	Pull Type	2	62-518-30-1X	—	63-35-34-1X	63-19-36-1X	63-15-5-1X++
-69	Ford	Pull Type	2	62-518-30-1X	—	63-35-34-1X	63-19-36-1X	63-15-5-1X++
-70	Ford	Pull Type	2	62-518-30-1X	—	63-35-34-1X	63-19-36-1X	63-15-5-1X++
-71	Drivetrain	Pull Type	2	62-518-29-1X	84	63-35-34-1X	63-19-36-1X	63-15-1-1X
-72	GMC	Push Type	2	312098X	—	63-35-47-1X	63-19-30-2-1X	63-15-1-1X
-73	Ford	Pull Type	2	62-518-29-1X	—	63-35-34-1X	63-19-36-1X	63-15-1-1X
-74	Ford	Pull Type	2	62-518-29-1X	—	63-35-34-1X	63-19-36-1X	63-15-5-1X++
-75	Diesel Equip.	Pull Type	2	62-518-29-1X	84	63-35-34-1X	63-19-36-1X	63-15-1-1X
-76	Bissinger/Stein	Pull Type	1	62-518-32-1X	80	63-35-34-1X	63-19-36-1X	63-15-1-1X
-77	Diesel Equip.	Pull Type	1	62-518-32-1X	84	63-35-34-1X	63-19-36-1X	63-15-1-1X
-78	Wich-Tex Mach.	Pull Type	1	62-518-32-1X	84	63-35-34-1X	63-19-36-1X	63-15-1-1X
-79	GMC	Pull Type	2	62-518-29-1X	—	63-35-34-1X	63-19-36-1X	63-15-1-1X
-80	Intl. Petroleum	Pull Type	2	62-518-29-1X	80	63-35-34-1X	63-19-36-1X	63-15-1-1X
-81	Blue Bird	Push Type	2	62-518-29-1X	56	63-35-34-1X	63-19-30-3-1X	63-15-1-1X
-82	Drivetrain	Push Type	2	62-518-27-1X	—	63-35-45-1X	63-19-31-1X	63-15-1-1X
-83	Volvo GM	Pull Type	2	62-518-29-1X	—	63-35-34-1X	63-19-36-1X	63-15-1-1X
-84	Drivetrain	Push Type	—	—	—	63-35-37-1X	63-19-21-1X	63-15-5-1X++
-85	Service	Pull Type	2	62-518-29-1X	15A	63-35-57-1X	63-19-36-1X	63-15-1-1X
-86	Cooper Inds.	Pull Type	1	62-518-32-1X	59	63-35-34-1X	63-19-36-1X	63-15-1-1X
-87	Hendrickson	Pull Type	2	62-518-29-1X	84	63-35-34-1X	63-16-36-1X	63-15-1-1X
-88	Trencor-Jetco	Pull Type	1	62-518-32-1X	59	63-35-34-1X	63-19-36-1X	63-15-1-1X
-89	Drivetrain	Pull Type	—	—	—	63-35-57-1X	63-19-36-1X	63-15-1-1X
-90	Drivetrain	Pull Type	—	—	—	63-35-34-1X	63-19-36-1X	63-15-5-1X++
-91	FWD Corp.	Pull Type	2	62-518-29-1X	91	63-35-34-1X	63-16-36-1X	63-15-1-1X
-92	GMC	Push Type	1	62-518-32-1X	—	63-35-34-1X	63-19-30-3-1X	63-15-1-1X
-93	GMC	Push Type	2	62-518-31-1X	—	63-35-34-1X	63-19-30-3-1X	63-15-1-1X
-94	GMC	Push Type	2	62-518-29-1X	—	63-35-34-1X	63-19-30-3-1X	63-15-1-1X
-95	Ford	Push Type	2	313243	—	63-35-37-1X	63-19-21-1X	63-15-5-1X++
-96	Ford	Pull Type	2	62-518-29-1X	—	63-35-34-1X	63-19-36-1X	63-15-15-1X
-97	Ford	Pull Type	2	62-518-29-1X	—	63-35-34-1X	63-19-36-1X	63-15-15-1X
-98	Pierce Mfg.	Pull Type	2	62-518-29-1X	84	63-35-34-1X	63-19-36-1X	63-15-1-1X
-99	Gillig Corp.	Pull Type	2	62-518-29-1X	91	63-35-34-1X	63-19-36-1X	63-15-1-1X

◀ Includes 97-454-2-1X consisting of (1) 97-454-2 Speedo Sleeve and (1) 97-463-34 Seal  
 ++ This part has been superseded by 63-15-15-1X for Service.

PARTS LISTED IN THIS CATALOG MAY NO LONGER BE AVAILABLE, USE WITH TRANSMISSION SUPERSEDING LIST.



# MODEL CM60

## TABULATED BILLS OF MATERIAL

T210-CM60

Tab No.	Mainshaft Rear Bearing Cap Assembly H-1 (incl. Bushing, Seal)	SPEEDOMETER		End Yoke or Companion Flange Page 16	SHIFTER		
		Drive Gear or Signal Gear B-24	Driven Gear H-7		Housing Ass'y Pages 12-13	Lever & Dome Ass'y Page 17	Remote Control Pages 14-15
<b>Model CM6052A (Cont'd)</b>							
<b>301253</b>							
-61	63-19-38-1X	—	—	—	63-16-1-1X	—	—
-62	63-19-38-1X	—	—	—	63-16-1-1X	—	—
-63	63-19-38-1X	—	—	—	63-16-1-1X	—	—
-64	63-19-33-2X	—	—	—	63-16-1-1X	—	—
-65	63-19-6-2X	—	—	—	63-16-3-1X	—	47-16-8-2X
-66	63-19-6-2X	—	—	4-1-3781	63-16-3-1X	—	47-16-8-2X
-67	63-19-38-1X	—	—	—	63-16-1-1X	—	—
-68	63-19-33-2X	—	—	—	63-16-1-1X	—	—
-69	63-19-38-1X	—	—	—	63-16-3-2X	—	—
-70	63-19-33-2X	—	—	—	63-16-3-2X	—	—
-71	63-19-6-2X	62-452-3	62-453-5	5-4-1661	63-16-1-1X	—	47-16-8-2X
-72	63-19-37-2X	62-452-9	—	—	63-16-9-1X	—	—
-73	63-19-38-1X	—	—	—	63-16-1-1X	—	—
-74	63-19-38-1X	—	—	—	63-16-1-1X	—	—
-75	63-19-6-2X	—	—	—	63-16-1-1X	47-16-3-1X	—
-76	63-19-6-2X	—	—	4-1-3781	63-16-3-1X	—	47-16-8-2X
-77	63-19-6-2X	—	—	5-1-3141	63-16-1-1X	47-16-3-1X	—
-78	63-19-6-2X	—	—	—	63-16-1-1X	47-16-3-1X	—
-79	63-19-37-2X	62-452-9	—	—	63-16-9-1X	—	—
-80	63-19-6-2X	—	—	5-1-3141	63-16-3-1X	47-16-3-1X	—
-81	63-19-6-2X	62-452-3	62-453-4	—	63-16-1-1X	—	—
-82	63-19-6-2X	62-452-3	62-453-4	5-4-1661	63-16-1-1X	—	—
-83	63-19-6-2X	62-452-3	—	—	63-16-1-1X	—	—
-84	63-19-38-1X	—	—	—	63-16-1-1X	—	—
-85	63-19-6-2X	53-452-4	53-453-2	6-4-2361	63-16-1-1X	—	47-16-8-3X
-86	63-19-6-2X	—	—	6-1-2221	63-16-1-1X	47-16-3-1X	—
-87	63-19-6-2X	62-452-2	—	—	63-16-1-1X	—	47-16-8-2X
-88	63-19-6-2X	—	—	5-1-3141	63-16-3-1X	47-16-5-22X	—
-89	63-19-10-2X	63-452-1	—	—	63-16-1-2X	—	—
-90	63-19-38-1X	—	—	—	63-16-1-1X	—	—
-91	63-19-6-2X	—	—	—	63-16-1-1X	—	—
-92	63-19-6-2X	62-452-9	—	—	63-16-9-1X	—	—
-93	63-19-6-2X	62-452-9	—	—	63-16-9-1X	—	—
-94	63-19-37-2X	62-452-9	—	—	63-16-9-1X	—	—
-95	63-19-38-1X	63-452-3	—	—	63-16-1-1X	—	—
-96	63-19-38-1X	63-452-3	—	5-4-7041-1	63-16-1-1X	—	—
-97	63-19-38-1X	63-452-3	—	6-4-3831-1	63-16-1-1X	—	—
-98	63-19-6-2X	62-452-9	62-453-8	6-4-2361	63-16-1-1X	—	—
-99	63-19-6-2X	—	—	5-1-3141	63-16-1-1X	—	—

# MODEL CM60

**SPICER®**



**T210-CM60**

## TABULATED BILLS OF MATERIAL

Tab No.	Used By	For Use With Clutch	CLUTCH HOUSING			Main Drive Gear A-1	Drive Gear Bearing Cap F-2	Case Assembly G-1
			S A E	Assembly No.	Rel. Code Pages 18-19			
<b>Model CM6052B</b>								
<b>301254</b>								
-1	Service	Pull Type	2	62-518-29-1X	—	63-35-34-1X	63-19-36-1X	63-15-1-1X
-2	Navistar	Push Type	—	—	—	63-35-48-1X	63-19-22-1X	63-15-1-1X
-3	Ford	Push Type	2	313243	—	63-35-37-1X	63-19-21-1X	63-15-15-1X
-4	Ford	—	—	—	—	63-35-38-1X	63-19-20-1X	63-15-11-1X
-5	Ford	Push Type	2	62-518-35-1X	—	63-35-37-1X	63-19-21-1X	63-15-15-1X
-6	Ford	Pull Type	2	62-518-30-1X	—	63-35-34-1X	63-19-36-1X	63-15-15-1X
-7	Tryco	Pull Type	2	62-518-29-1X	59	63-35-34-1X	63-19-36-1X	63-15-9-1X
-8	Gradall	Push Type	2	62-518-27-1X	43	63-35-45-1X	63-19-31-1X	63-15-1-1X
-9	GMC	Push Type	—	—	—	63-35-47-1X	63-19-30-2-1X	63-15-1-3X
-10	DSD	Pull Type	1	62-518-32-1X	84	63-35-34-1X	63-19-36-1X	63-15-1-1X
-11	Jack Tidd	Pull Type	1	62-518-32-1X	90	63-35-34-1X	63-19-36-1X	63-15-1-1X
-12§	GMC	Push Type	—	—	—	63-35-47-1X	63-19-30-2-1X	63-15-1-3X
-13	Ward LaFrance	Pull Type	1	62-518-32-1X	94	63-35-34-1X	63-19-36-1X	63-15-1-1X
-14	Ford	Push Type	2	313243	—	63-35-37-1X	63-19-21-1X	63-15-15-1X
-15	Bombardier	Push Type	2	62-518-27-1X	39	63-35-45-1X	63-19-31-1X	63-15-1-1X
-16	DSD	Pull Type	2	62-518-29-1X	94	63-35-34-1X	63-19-36-1X	63-15-1-1X
-17§	DSD	Push Type	—	—	—	63-35-45-1X	63-19-31-1X	63-15-1-1X
-18§	DSD	Push Type	—	—	—	63-35-34-1X	63-19-30-3-1X	63-15-1-1X
-19	GMC	Push Type	2	312098X	—	63-35-47-1X	63-19-30-2-1X	63-15-1-3X
-20	DSD	Push Type	2	62-518-27-1X	45	63-35-45-1X	63-19-31-1X	63-15-1-1X
-21	GMC	Push Type	—	—	—	63-35-47-1X	63-19-30-2-1X	63-15-1-3X
-22	GMC	Push Type	—	—	—	63-35-47-1X	63-19-30-2-1X	63-15-3-1X
-23	Mack	Pull Type	1	62-518-32-1X	46A	63-35-34-1X	63-19-36-1X	63-15-1-1X
-24	Navistar	Pull Type	2	62-518-29-1X	—	63-35-34-1X	63-19-36-1X	63-15-1-1X
-25	Service	Pull Type	2	62-518-29-1X	84	63-35-34-1X	63-19-36-1X	63-15-1-1X
-26	DWT	Push Type	2	62-518-27-1X	57	63-35-45-1X	63-19-31-1X	63-15-1-1X
-27	FWD Corp.	Push Type	2	62-518-27-1X	45	63-35-45-1X	63-19-31-1X	63-15-1-1X
-28	Hahn Motors	Pull Type	1	62-518-32-1X	90	63-35-34-1X	63-19-36-1X	63-15-1-1X
-29	Ford	Push Type	2	62-518-30-1X	—	63-35-34-1X	63-19-36-1X	63-15-15-1X
-30	Mack	Pull Type	2	62-518-36-1X	—	63-35-34-1X	63-19-36-1X	63-15-1-1X
-31	Kenworth	Pull Type	1	62-518-32-1X	64	63-35-34-1X	63-19-36-1X	63-15-1-1X
-32	GMC	Pull Type	2	62-518-31-1X	—	63-35-34-1X	63-19-36-1X	63-15-1-1X
-33	Navistar	Pull Type	2	62-518-29-1X	—	63-35-57-1X	63-19-36-1X	63-15-1-1X
-34	DWT	Push Type	2	62-518-29-1X	44	63-35-34-1X	63-19-30-3-1X	63-15-1-1X
-35	Navistar	Pull Type	2	62-518-29-1X	—	63-35-57-1X	63-19-36-1X	63-15-1-1X
-36	Gillig	Pull Type	1	62-518-32-1X	68	63-35-34-1X	63-19-36-1X	63-15-1-1X
-37	Navistar	Pull Type	2	62-518-29-1X	—	63-35-34-1X	63-19-36-1X	63-15-1-1X
-38	Am. LaFrance	Push Type	1	62-518-32-1X	113	63-35-34-1X	63-19-30-3-1X	63-15-1-1X
-39★	Thos. Built Bus	Pull Type	2	62-518-29-1X	75	63-35-34-1X	63-19-36-1X	63-15-1-1X
-40	Spartan Motors	Pull Type	2	62-518-29-1X	88	63-35-34-1X	63-19-36-1X	63-15-1-1X

§ Short Box

★ Includes 313263X Kit-Neutral Start Switch Actuator

PARTS LISTED IN THIS CATALOG MAY NO LONGER BE AVAILABLE, USE WITH TRANSMISSION SUPERSEDING LIST.



# MODEL CM60

## TABULATED BILLS OF MATERIAL

T210-CM60

Tab No.	Mainshaft Rear Bearing Cap Assembly H-1 (incl. Bushing, Seal)	SPEEDOMETER		End Yoke or Companion Flange Page 16	SHIFTER		
		Drive Gear or Signal Gear B-24	Driven Gear H-7		Housing Ass'y Pages 12-13	Lever & Dome Ass'y Page 17	Remote Control Pages 14-15
<b>Model CM6052B</b>							
<b>301254</b>							
-1	63-19-6-2X	62-452-3	62-453-4	6-4-2361	63-16-1-1X	—	—
-2	63-19-10-2X	63-452-1	—	—	63-16-1-2X	—	—
-3	• 47-360-1	—	—	—	63-16-1-1X	—	—
-4	• 47-360-1	—	—	—	63-16-1-1X	—	—
-5	• 47-360-1	—	—	—	63-16-3-2X	—	—
-6	• 47-360-1	—	—	—	63-16-1-1X	—	—
-7	63-19-37-2X	62-452-3	62-453-5	5-1-278X	63-16-1-1X	—	47-16-8-2X
-8	63-19-6-2X	—	—	5-4-1661	63-16-1-1X	—	47-16-8-3X
-9	63-19-37-2X	—	—	—	—	—	—
-10	63-19-6-2X	62-452-3	62-453-4	5-4-1661	63-16-1-1X	47-16-3-1X	—
-11	63-19-6-2X	—	—	5-1-3141	63-16-3-1X	—	47-16-8-2X
-12	—	—	—	—	—	—	—
-13	63-19-6-2X	62-452-9	62-453-8	6-1-2221	63-16-3-1X	—	—
-14	• 47-360-1	—	—	—	63-16-1-1X	—	—
-15	63-19-6-2X	—	—	5-1-3141	63-16-1-1X	—	47-16-8-2X
-16	63-19-6-2X	62-452-3	62-453-5	—	63-16-3-1X	47-16-3-1X	—
-17	63-19-6-2X	—	—	—	—	—	—
-18	63-19-6-2X	—	—	—	—	—	—
-19	63-19-6-2X	62-452-9	—	—	63-16-9-1X	—	—
-20	63-19-6-2X	62-452-2	62-452-1	4-1-3781	63-16-3-1X	—	47-16-8-2X
-21	63-19-37-2X	—	—	—	63-16-9-1X	—	—
-22	63-19-6-2X	—	—	—	63-16-9-1X	—	—
-23	63-19-27-2X	—	—	6-4-2361	63-16-3-2X	47-16-5-9X	—
-24	63-19-10-2X	63-452-1	—	—	63-16-1-2X	—	—
-25	63-19-6-2X	62-452-3	62-453-5	6-1-2221	63-16-3-1X	47-16-3-1X	—
-26	63-19-6-2X	62-452-3	62-453-5	4-1-3781	63-16-3-1X	47-16-3-1X	—
-27	63-19-6-2X	—	—	—	63-16-1-1X	—	47-16-8-2X
-28	63-19-6-2X	62-452-3	62-453-5	6-1-2221	63-16-3-1X	—	47-16-8-2X
-29	• 47-360-1	—	—	—	63-16-3-2X	—	—
-30	63-19-6-2X	—	—	—	63-16-1-1X	—	—
-31	63-19-6-2X	62-452-3	62-453-5	6-4-2361	63-16-1-1X	47-16-3-1X	—
-32	63-19-6-2X	62-452-9	—	—	63-16-9-1X	—	—
-33	63-19-8-2X	63-452-1	—	—	63-16-1-2X	—	—
-34	63-19-6-2X	—	—	—	63-16-3-1X	—	—
-35	63-19-10-2X	63-452-1	—	—	63-16-1-2X	—	—
-36	63-19-6-2X	—	—	—	63-16-3-1X	—	47-16-8-5X
-37	63-19-8-2X	63-452-1	—	—	63-16-1-2X	—	—
-38	63-19-6-2X	—	—	—	63-16-3-1X	—	47-16-8-2X
-39	63-19-6-2X	—	—	5-4-1661	63-16-1-1X	—	47-16-9-2X
-40	63-19-6-2X	—	—	6-1-2221	63-16-1-1X	—	47-16-8-3X

•Rear Bearing Retainer

PARTS LISTED IN THIS CATALOG MAY NO LONGER BE AVAILABLE, USE WITH TRANSMISSION SUPERSEDING LIST.

# MODEL CM60

**SPICER®**



**T210-CM60**

## TABULATED BILLS OF MATERIAL

Tab No.	Used By	For Use With Clutch	CLUTCH HOUSING			Main Drive Gear A-1	Drive Gear Bearing Cap F-2	Case Assembly G-1
			S A E	Assembly No.	Rel. Code Pages 18-19			
<b>Model CM6052B (Cont'd)</b>								
<b>301254</b>								
-41	Ford	Pull Type	2	62-518-30-1X	—	63-35-34-1X	63-19-36-1X	63-15-15-1X
-42	Ford	Push Type	2	313243	—	63-35-37-1X	63-19-21-1X	63-15-15-1X
-43	Ford	Pull Type	2	62-518-30-1X	—	63-35-34-1X	63-19-36-1X	63-15-15-1X
-44	Ford	Pull Type	2	62-518-30-1X	—	63-35-34-1X	63-19-36-1X	63-15-15-1X
-45	Ford	Pull Type	2	62-518-30-1X	—	63-35-34-1X	63-19-36-1X	63-15-15-1X
-46	Ford	Pull Type	2	62-518-30-1X	—	63-35-34-1X	63-19-36-1X	63-15-15-1X
-47	Simon-Duplex	Pull Type	2	62-518-29-1X	84	63-35-34-1X	63-19-36-1X	63-15-1-1X
-48	Ford	Pull Type	2	62-518-29-1X	—	63-35-34-1X	63-19-36-1X	63-15-15-1X
-49	Ford	Push Type	2	313243	—	63-35-37-1X	63-19-21-1X	63-15-15-1X
-50	Spicer U.K.	Push Type	1	62-518-32-1X	112A	63-35-34-1X	63-19-30-3-1X	63-15-1-1X
-51	Ford	Pull Type	2	62-518-29-1X	—	63-35-34-1X	63-19-36-1X	63-15-15-1X
-52	DWT	Pull Type	2	62-518-27-1X	15B	63-35-45-1X	63-19-36-1X	63-15-1-1X
-53§	Capitol Trencher	Push Type	—	—	—	63-35-38-1X	63-19-20-1X	63-15-16-1X*
-54	Osterlund	Pull Type	2	62-518-29-1X	—	63-35-34-1X	63-19-36-1X	63-15-1-1X
-55	Blue Bird	Push Type	2	62-518-29-1X	56	63-35-34-1X	63-19-30-3-1X	63-15-1-1X
-56★	Thos. Built Bus.	Pull Type	2	62-518-29-1X	75	63-35-34-1X	63-19-36-1X	63-15-1-1X
-57	Service	Push Type	2	62-518-29-1X	39	63-35-34-1X	63-19-30-3-1X	63-15-1-1X
-58	Cooper Inds.	Pull Type	1	62-518-32-1X	—	63-35-34-1X	63-19-36-1X	63-15-1-1X
-59§	DSD	Push Type	—	—	—	63-35-37-1X	63-19-21-1X	63-15-15-1X
-60	Gradall	Push Type	2	62-518-27-1X	43	63-35-45-1X	63-19-31-1X	63-15-1-1X
-61	Ford	Pull Type	2	62-518-29-1X	—	63-35-34-1X	63-19-36-1X	63-15-15-1X
-62	Ford	Pull Type	2	62-518-29-1X	—	63-35-34-1X	63-19-36-1X	63-15-15-1X
-63	Gradall	Pull Type	2	62-518-29-1X	93	63-35-57-1X	63-19-36-1X	63-15-1-1X
-64■	Service	Pull Type	2	62-518-29-1X	93	63-35-34-1X	63-19-36-1X	63-15-1-1X
<b>Model CM6052C</b>								
<b>301255</b>								
-1	Service	Pull Type	2	62-518-29-1X	—	63-35-46-1X	63-19-36-1X	63-15-1-1X
-2	Never Released for Production							
-3	Navistar	Pull Type	—	—	—	63-35-46-1X	63-19-36-1X	63-15-1-1X
-4	Ford	Push Type	2	313243	—	63-35-39-1X	63-19-21-1X	63-15-15-1X
-5	Never Released for Production							
-6	Am. LaFrance	Push Type	2	62-518-29-1X	113	63-35-46-1X	63-19-30-3-1X	63-15-1-1X
-7	GMC	Push Type	2	312098X	—	63-35-52-1X	63-19-30-2-1X	63-15-1-1X
-8	GMC	Pull Type	2	62-518-31-1X	—	63-35-46-1X	63-19-36-1X	63-15-1-1X
-9	Never Released for Production							
-10	Never Released for Production							
-11	Omnibuses S.A.	Pull Type	2	62-518-29-1X	90	63-35-46-1X	63-19-36-1X	63-15-1-1X
-12	Never Released for Production							
-13	Volvo GM	Push Type	2	62-518-29-1X	—	63-35-46-1X	63-19-30-3-1X	63-15-1-1X
-14	Volvo GM	Push Type	2	62-518-29-1X	—	63-35-46-1X	63-19-36-1X	63-15-1-1X
-15§	GMC	Push Type	—	—	—	63-35-52-1X	63-19-30-2-1X	63-15-1-1X

§ Short Box

★ Includes 313263X Kit-Neutral Start Switch Actuator

■ Includes 3918-107 Independent Remote Control

\* This part has been superseded by 63-15-11-1X for Service

PARTS LISTED IN THIS CATALOG MAY NO LONGER BE AVAILABLE, USE WITH TRANSMISSION SUPERSEDING LIST.



Tab No.	Mainshaft Rear Bearing Cap Assembly H-1 (incl. Bushing, Seal)	SPEEDOMETER		End Yoke or Companion Flange Page 16	SHIFTER		
		Drive Gear or Signal Gear B-24	Driven Gear H-7		Housing Ass'y Pages 12-13	Lever & Dome Ass'y Page 17	Remote Control Pages 14-15

**Model CM6052B (Cont'd)**

**301254**

-41	63-19-38-1X	63-452-2	63-453-1	6-4-3831	63-16-1-1X	—	—
-42	63-19-38-1X	—	—	—	63-16-1-1X	—	—
-43	63-19-38-1X	—	—	—	63-16-1-1X	—	—
-44	63-19-33-1X	—	—	—	63-16-1-1X	—	—
-45	63-19-38-1X	—	—	—	63-16-1-2X	—	—
-46	63-19-33-2X	—	—	—	63-16-3-2X	—	—
-47	63-19-6-2X	—	—	—	63-16-3-1X	—	—
-48	63-19-38-1X	—	—	—	63-16-1-1X	—	—
-49	63-19-33-2X	—	—	—	63-16-1-1X	—	—
-50	63-19-6-2X	—	—	5-1-3141	63-16-3-1X	—	47-16-8-2X
-51	63-19-33-2X	—	—	—	63-16-1-1X	—	—
-52	63-19-6-2X	62-452-3	62-453-5	5-4-1661	63-16-1-1X	47-16-3-1X	—
-53	63-19-38-1X	—	—	—	63-16-1-1X	—	—
-54	63-19-6-2X	62-452-3	62-453-4	6-4-2361	63-16-1-1X	47-16-3-1X	—
-55	63-19-6-2X	62-452-3	62-453-4	—	63-16-1-1X	—	—
-56	63-19-6-2X	—	—	5-4-1661	63-16-1-1X	—	—
-57	63-19-6-2X	62-452-3	62-453-4	5-4-1661	63-16-1-1X	—	—
-58	63-19-6-2X	—	—	6-1-2221	63-16-1-1X	47-16-3-1X	—
-59	63-19-38-1X	—	—	—	63-16-3-2X	—	—
-60	63-19-6-2X	—	—	5-4-1661	63-16-1-1X	—	—
-61	63-19-38-1X	63-452-3	—	5-4-7041-1	63-16-1-1X	—	—
-62	63-19-38-1X	63-452-3	—	6-4-3831-1	63-16-1-1X	—	—
-63	63-19-6-2X	—	—	5-4-1661	63-16-1-1X	—	47-16-8-3X
-64	63-19-6-2X	62-452-3	62-453-4	6-1-2221	63-16-1-1X	—	47-16-8-3X

**Model CM6052C**

**301255**

-1	63-19-6-2X	62-452-3	62-453-4	6-4-2361	63-16-1-1X	—	—
-2	Never Released for Production	—	—	—	—	—	—
-3	63-19-10-2X	63-452-1	—	—	63-16-1-2X	—	—
-4	•47-360-1	—	—	—	63-16-1-1X	—	—
-5	Never Released for Production	—	—	—	—	—	—
-6	63-19-6-2X	—	—	—	63-16-3-1X	—	47-16-8-2X
-7	63-19-6-2X	62-452-9	—	—	63-16-9-1X	—	—
-8	63-19-6-2X	62-452-9	—	—	63-16-9-1X	—	—
-9	Never Released for Production	—	—	—	—	—	—
-10	Never Released for Production	—	—	—	—	—	—
-11	63-19-27-2X	62-452-2	62-452-1	6-4-2361	63-16-1-1X	—	47-16-8-2X
-12	Never Released for Production	—	—	—	—	—	—
-13	63-19-6-2X	—	—	—	63-16-3-1X	—	—
-14	63-19-6-2X	—	—	—	63-16-3-1X	—	—
-15	63-19-6-2X	—	—	—	—	—	—

•Rear Bearing Retainer

# MODEL CM60

**SPICER®**



**T210-CM60**

## TABULATED BILLS OF MATERIAL

Tab No.	Used By	For Use With Clutch	CLUTCH HOUSING			Main Drive Gear A-1	Drive Gear Bearing Cap F-2	Case Assembly G-1
			S A E	Assembly No.	Rel. Code Pages 18-19			
<b>Model CM6052C (Cont'd)</b>								
<b>301255</b>								
-16§	GMC	Pull Type	—	—	—	63-35-46-1X	63-19-36-1X	63-15-1-1X
-17	Volvo GM	Pull Type	2	62-518-29-1X	—	63-35-46-1X	63-19-36-1X	63-15-1-1X
-18	Mack	Pull Type	1	62-518-32-1X	—	63-35-46-1X	63-19-36-1X	63-15-1-1X
-19	Never Released for Production							
-20	Never Released for Production							
-21	DSD	Pull Type	1	62-518-32-1X	84	63-35-46-1X	63-19-36-1X	63-15-1-1X
-22	Navistar	Pull Type	1	62-518-32-1X	—	63-35-46-1X	63-19-36-1X	63-15-1-1X
-23	Navistar	Pull Type	2	62-518-29-1X	—	63-35-46-1X	63-19-36-1X	63-15-1-1X
-24	DSD	Push Type	—	—	—	63-35-46-1X	63-19-30-3-1X	63-15-1-1X
-25	DSD	Push Type	—	—	—	63-35-39-1X	63-19-21-1X	63-15-1-1X
-26	Navistar	Push Type	2	73-518-3	—	63-35-49-1X	63-19-22-1X	63-15-1-1X
-27	GMC	Push Type	—	—	—	63-35-52-1X	63-19-30-2-1X	63-15-1-1X
-28	GMC	Push Type	2	312098X	—	63-35-52-1X	63-19-30-2-1X	63-15-1-1X
-29	DSD	Push Type	2	62-518-29-1X	43	63-35-46-1X	63-19-30-3-1X	63-15-1-1X
-30	Never Released for Production							
-31	Geo Space	Pull Type	1	62-518-32-1X	90	63-35-46-1X	63-19-36-1X	63-15-1-1X
-32	Never Released for Production							
-33	Navistar	Pull Type	2	62-518-29-1X	—	63-35-56-1X	63-19-36-1X	63-15-1-1X
-34	Navistar	Pull Type	2	62-518-29-1X	—	63-35-56-1X	63-19-36-1X	63-15-1-1X
-35	Am. LaFrance	Push Type	1	62-518-32-1X	113	63-35-46-1X	63-19-30-3-1X	63-15-1-1X
-36	Navistar	Pull Type	2	62-518-29-1X	—	63-35-46-1X	63-19-36-1X	63-15-1-1X
-37	GMC	Pull Type	2	62-518-31-1X	—	63-35-46-1X	63-19-36-1X	63-15-3-1X
-38	Never Released for Production							
-39§	Ford	Push Type	—	—	—	63-35-40-1X	63-19-20-1X	63-15-16-1X*
-40	Ford	Push Type	—	—	—	63-35-40-1X	63-19-20-1X	63-15-16-1X*
-41	Ford	Push Type	2	313243	—	63-35-39-1X	63-19-21-1X	63-15-15-1X
-42	Ford	Push Type	2	313243	—	63-35-39-1X	63-19-21-1X	63-15-15-1X
-43	Ford	Pull Type	2	62-518-30-1X	—	63-35-46-1X	63-19-36-1X	63-15-15-1X
-44	Ford	Pull Type	2	62-518-30-1X	—	63-35-46-1X	63-19-36-1X	63-15-15-1X
-45	Ford	Pull Type	2	62-518-30-1X	—	63-35-46-1X	63-19-36-1X	63-15-15-1X
-46	Ford	Pull Type	2	62-518-30-1X	—	63-35-46-1X	63-19-36-1X	63-15-15-1X
-47	Never Released for Production							
-48	Ford	Pull Type	2	62-518-29-1X	—	63-35-46-1X	63-19-36-1X	63-15-15-1X
-49	Ford	Pull Type	2	62-518-29-1X	—	63-35-46-1X	63-19-36-1X	63-15-15-1X
-50	GMC	Push Type	2	62-518-29-1X	—	63-35-46-1X	63-19-30-3-1X	63-15-1-1X
-51	GMC	Push Type	2	312098X	—	63-35-52-1X	63-19-30-2-1X	63-15-3-1X
-52	Diesel Equip.	Pull Type	2	62-518-29-1X	84	63-35-46-1X	63-19-36-1X	63-15-1-1X
-53	Ford	Push Type	2	62-518-35-1X	—	63-35-39-1X	63-19-21-1X	63-15-15-1X
-54	GMC	Pull Type	2	62-518-29-1X	—	63-35-46-1X	63-19-36-1X	63-15-1-1X
-55	Am. LaFrance	Pull Type	1	62-518-32-1X	96A	63-35-46-1X	63-19-36-1X	63-15-1-1X

§ Short Box

\* This part has been superseded by 63-15-11-1X for Service

PARTS LISTED IN THIS CATALOG MAY NO LONGER BE AVAILABLE, USE WITH TRANSMISSION SUPERSEDING LIST.





Tab No.	Mainshaft Rear Bearing Cap Assembly H-1 (incl. Bushing, Seal)	SPEEDOMETER		End Yoke or Companion Flange Page 16	SHIFTER		
		Drive Gear or Signal Gear B-24	Driven Gear H-7		Housing Ass'y Pages 12-13	Lever & Dome Ass'y Page 17	Remote Control Pages 14-15
<b>Model CM6052C (Cont'd)</b>							
<b>301255</b>							
-16	63-19-6-2X	—	—	—	—	—	—
-17	63-19-6-2X	—	—	—	63-16-1-1X	—	—
-18	63-19-6-2X	—	—	—	63-16-1-1X	—	—
-19	Never Released for Production						
-20	Never Released for Production						
-21	63-19-6-2X	62-452-3	62-453-4	—	63-16-1-1X	47-16-3-1X	—
-22	63-19-10-2X	63-452-1	—	—	63-16-1-2X	—	—
-23	63-19-10-2X	63-452-1	—	—	63-16-1-2X	—	—
-24	63-19-6-2X	—	—	—	—	—	—
-25	63-19-10-2X	63-452-1	—	—	63-16-1-2X	—	—
-26	63-19-10-2X	63-452-1	—	—	63-16-1-2X	—	—
-27	63-19-6-2X	—	—	—	63-16-9-1X	—	—
-28	63-19-36-2X	62-452-9	—	—	63-16-9-1X	—	—
-29	63-19-6-2X	—	—	6-1-2221	63-16-1-1X	47-16-3-1X	—
-30	Never Released for Production						
-31	63-19-6-2X	—	—	—	63-16-1-1X	—	—
-32	Never Released for Production						
-33	63-19-10-2X	63-452-1	—	—	63-16-1-2X	—	—
-34	63-19-8-2X	63-452-1	—	—	63-16-1-2X	—	—
-35	63-19-6-2X	—	—	—	63-16-3-1X	—	47-16-8-2X
-36	63-19-8-2X	63-452-1	—	—	63-16-1-2X	—	—
-37	63-19-6-2X	62-452-9	—	—	63-16-9-1X	—	—
-38	Never Released for Production						
-39	63-19-38-1X	—	—	—	—	—	—
-40	63-19-33-2X	—	—	—	63-16-1-1X	—	—
-41	63-19-38-1X	—	—	—	63-16-1-1X	—	—
-42	63-19-33-2X	—	—	—	63-16-1-1X	—	—
-43	63-19-38-1X	—	—	—	63-16-1-1X	—	—
-44	63-19-33-2X	—	—	—	63-16-1-1X	—	—
-45	63-19-38-1X	—	—	—	63-16-3-2X	—	—
-46	63-19-33-2X	—	—	—	63-16-3-2X	—	—
-47	Never Released for Production						
-48	63-19-38-1X	—	—	—	63-16-1-1X	—	—
-49	63-19-33-2X	—	—	—	63-16-1-1X	—	—
-50	63-19-6-2X	62-452-9	—	—	63-16-9-1X	—	—
-51	63-19-6-2X	62-452-9	—	—	63-16-9-1X	—	—
-52	63-19-6-2X	—	—	—	63-16-1-1X	—	—
-53	63-19-38-1X	—	—	—	63-16-3-2X	—	—
-54	63-19-37-2X	62-452-9	—	—	63-16-9-1X	—	—
-55	63-19-6-2X	—	—	—	63-16-3-1X	—	47-16-8-2X

# MODEL CM60

SPICER®



T210-CM60

## TABULATED BILLS OF MATERIAL

Tab No.	Used By	For Use With Clutch	CLUTCH HOUSING			Main Drive Gear A-1	Drive Gear Bearing Cap F-2	Case Assembly G-1
			S A E	Assembly No.	Rel. Code Pages 18-19			

### Model CM6052C (Cont'd)

#### 301255

-56§	DSD	Push Type	—	—	—	63-35-39-1X	63-19-21-1X	63-15-15-1X
-57	GMC	Push Type	2	62-518-29-1X	—	63-35-46-1X	63-19-30-3-1X	63-15-1-1X
-58	Ford	Push Type	2	313243	—	63-35-39-1X	63-19-21-1X	63-15-15-1X
-59	Ford	Pull Type	2	62-518-29-1X	—	63-35-46-1X	63-19-36-1X	63-15-15-1X
-60	Ford	Pull Type	2	62-518-29-1X	—	63-35-46-1X	63-19-36-1X	63-15-15-1X
-61	FWD Corp.	Pull Type	2	62-518-29-1X	91	63-35-46-1X	63-19-36-1X	63-15-1-1X

### Model CM6052D

#### 301256

-1	Never Released for Production							
-2	Navistar	Pull Type	2	62-518-29-1X	—	63-35-34-1X	63-19-36-1X	63-15-1-1X
-3	Navistar	Pull Type	2	62-518-29-1X	—	63-35-57-1X	63-19-36-1X	63-15-1-1X
-4	Never Released for Production							
-5	Ford	Pull Type	2	62-518-30-1X	—	63-35-34-1X	63-19-36-1X	63-15-15-1X
-6	Ford	Pull Type	2	62-518-30-1X	—	63-35-34-1X	63-19-36-1X	63-15-15-1X
-7	Ford	Push Type	2	313243	—	63-35-37-1X	63-19-21-1X	63-15-15-1X
-8	Ford	Push Type	2	313243	—	63-35-37-1X	63-19-21-1X	63-15-15-1X
-9	Navistar	Pull Type	2	62-518-29-1X	—	63-35-57-1X	63-19-36-1X	63-15-1-1X
-10	Ford	Pull Type	2	62-518-29-1X	—	63-35-34-1X	63-19-36-1X	63-15-15-1X
-11	Ford	Pull Type	2	62-518-29-1X	—	63-35-34-1X	63-19-36-1X	63-15-15-1X
-12	Mack	Pull Type	2	62-518-36-1X	—	63-35-34-1X	63-19-36-1X	63-15-1-1X
-13	Navistar	Pull Type	1	62-518-32-1X	—	63-35-34-1X	63-19-36-1X	63-15-1-1X
-14	DWT	Pull Type	2	62-518-29-1X	84	63-35-34-1X	63-19-36-1X	63-15-1-1X
-15	RVI	Push Type	—	—	—	63-35-53-1X	63-19-30-4-1X	63-15-1-1X
-16	GMC	Push Type	2	312098X	—	63-35-47-1X	63-19-30-2-1X	63-15-1-1X
-17	GMC	Pull Type	2	62-518-31-1X	—	63-35-34-1X	63-19-36-1X	63-15-1-1X
-18	Service	Push Type	2	62-518-27-1X	—	63-35-45-1X	63-19-31-1X	63-15-1-1X
-19	GMC	Push Type	2	62-518-31-1X	—	63-35-34-1X	63-19-30-3-1X	63-15-1-1X
-20	GMC	Pull Type	2	62-518-31-1X	—	63-35-34-1X	63-19-36-1X	63-15-1-1X
-21	Ford	Push Type	2	313243	—	63-35-37-1X	63-19-21-1X	63-15-15-1X

### Model CM6252B

#### 301258

-1	Service	Pull Type	2	62-518-29-1X	—	63-35-36-1X	63-19-36-1X	63-15-1-1X
-2	Am. LaFrance	Push Type	1	62-518-32-1X	113	63-35-36-1X	63-19-30-3-1X	63-15-1-1X
-3	Gillig Corp.	Pull Type	2	62-518-29-1X	91	63-35-36-1X	63-19-36-1X	63-15-1-1X
-4	Never Released for Production							
-5	Hendrickson	Pull Type	2	62-518-29-1X	84	63-35-36-1X	63-19-36-1X	63-15-1-1X
-6	Hahn Motors	Pull Type	1	62-518-32-1X	90	63-35-36-1X	63-19-36-1X	63-15-1-1X
-7*	Clev. Trencher	Pull Type	1	62-518-32-1X	59	63-35-36-1X	63-19-36-1X	63-15-1-1X
-8*	Clev. Trencher	Pull Type	1	62-518-32-1X	59	63-35-36-1X	63-19-36-1X	63-15-1-1X
-9	Badger Equip.	Pull Type	2	62-518-29-1X	90	63-35-36-1X	63-19-36-1X	63-15-1-1X
-10	Mack	Pull Type	1	62-518-32-1X	46A	63-35-36-1X	63-19-36-1X	63-15-1-1X

§ Short Box

\* Transmission is unsynchronized and 5th speed is blocked out.

PARTS LISTED IN THIS CATALOG MAY NO LONGER BE AVAILABLE, USE WITH TRANSMISSION SUPERSEDING LIST.



Tab No.	Mainshaft Rear Bearing Cap Assembly H-1 (Incl. Bushing, Seal)	SPEEDOMETER		End Yoke or Companion Flange Page 16	SHIFTER		
		Drive Gear or Signal Gear B-24	Driven Gear H-7		Housing Ass'y Pages 12-13	Lever & Dome Ass'y Page 17	Remote Control Pages 14-15

**Model CM6052C (Cont'd)**

**301255**

-56	63-19-38-1X	—	—	—	—	—	—
-57	63-19-37-2X	62-452-9	—	—	63-16-9-1X	—	—
-58	63-19-38-1X	63-452-3	—	5-4-7041-1	63-16-1-1X	—	—
-59	63-19-38-1X	63-452-3	—	5-4-7041-1	63-16-1-1X	—	—
-60	63-19-38-1X	63-452-3	—	6-4-3831-1	63-16-1-1X	—	—
-61	63-19-6-2X	—	—	—	63-16-1-1X	—	—

**Model CM6052D**

**301256**

-1	Never Released for Production						
-2	63-19-10-2X	63-452-1	—	—	63-16-1-2X	—	—
-3	63-19-10-2X	63-452-1	—	—	63-16-1-2X	—	—
-4	Never Released for Production						
-5	63-19-38-1X	—	—	—	63-16-1-1X	—	—
-6	63-19-33-2X	—	—	—	63-16-1-1X	—	—
-7	63-19-38-1X	—	—	—	63-16-1-1X	—	—
-8	63-19-33-2X	—	—	—	63-16-1-1X	—	—
-9	63-19-8-2X	63-452-1	—	—	63-16-1-2X	—	—
-10	63-19-38-1X	—	—	—	63-16-1-1X	—	—
-11	63-19-33-2X	—	—	—	63-16-1-1X	—	—
-12	63-19-6-2X	—	—	—	63-16-1-1X	—	—
-13	63-19-10-2X	63-452-1	—	—	63-16-1-2X	—	—
-14	63-19-6-2X	62-452-3	62-453-5	6-4-2361	63-16-1-1X	47-16-5-38X	—
-15	63-19-6-2X	53-452-4	53-453-2	5-4-1661	63-16-1-1X	47-16-5-38X	—
-16	63-19-6-2X	62-452-9	—	—	63-16-9-1X	—	—
-17	63-19-6-2X	62-452-9	—	—	63-19-9-1X	—	—
-18	63-19-6-2X	—	—	—	63-16-1-1X	47-16-3-25X	—
-19	63-19-6-2X	62-452-9	—	—	63-16-9-1X	—	—
-20	63-19-6-2X	62-452-9	—	—	63-16-9-1X	—	—
-21	63-19-38-1X	63-452-3	—	5-4-7041-1	63-16-1-1X	—	—

**Model CM6252B**

**301258**

-1	63-19-6-2X	62-452-3	62-453-4	6-4-2361	63-16-1-1X	—	—
-2	63-19-6-2X	—	—	—	63-16-3-1X	—	47-16-8-2X
-3	63-19-6-2X	—	—	5-1-3141	63-16-1-1X	—	47-16-8-4X
-4	Never Released for Production						
-5	63-19-6-2X	62-452-2	—	—	63-16-1-1X	—	47-16-8-2X
-6	63-19-6-2X	62-452-3	62-453-5	6-1-2221	63-16-3-1X	—	47-16-8-2X
-7	63-19-27-2X	—	—	5-1-3141	63-16-3-4X	—	47-16-8-2X
-8	63-19-27-2X	—	—	5-1-3141	63-16-3-4X	—	47-16-8-2X
-9	63-19-6-2X	62-452-3	62-453-4	—	63-16-3-1X	—	47-16-8-2X
-10	63-19-27-2X	—	—	5-1-3141	63-16-1-1X	—	47-16-8-4X

# MODEL CM60

**SPICER®**



**T210-CM60**

## TABULATED BILLS OF MATERIAL

Tab No.	Used By	For Use With Clutch	CLUTCH HOUSING			Main Drive Gear A-1	Drive Gear Bearing Cap F-2	Case Assembly G-1
			S A E	Assembly No.	Rel. Code Pages 18-19			
<b>Model CM6252B (Cont'd)</b>								
<b>301258</b>								
-11	Mack	Pull Type	1	62-518-32-1X	46A	63-35-36-1X	63-19-36-1X	63-15-1-1X
-12	Hahn Motors	Pull Type	2	62-518-29-1X	90	63-35-36-1X	63-19-36-1X	63-15-1-1X
-13	Hahn Motors	Pull Type	2	62-518-29-1X	90	63-35-36-1X	63-19-36-1X	63-15-1-1X
-14	Hahn Motors	Pull Type	2	62-518-29-1X	90	63-35-36-1X	63-19-36-1X	63-15-1-1X
-15	FWD Corp.	Pull Type	1	62-518-32-1X	90	63-35-36-1X	63-19-36-1X	63-15-1-1X
-16	Spartan Motors	Pull Type	2	62-518-29-1X	90	63-35-36-1X	63-19-36-1X	63-15-1-1X
-17	Mack	Pull Type	1	62-518-32-1X	46A	63-35-36-1X	63-19-36-1X	63-15-1-1X
-18	Mack	Pull Type	1	62-518-32-1X	46A	63-35-36-1X	63-19-36-1X	63-15-1-1X
-19	Mack	Pull Type	1	62-518-32-1X	46A	63-35-36-1X	63-19-36-1X	63-15-1-1X
-20	Crown Coach	Pull Type	1	62-518-32-1X	86	63-35-36-1X	63-19-36-1X	63-15-1-1X
-21§	DSD	Push Type	—	—	—	63-35-36-1X	63-19-30-3-1X	63-15-1-1X
-22**	Spicer Australia	Pull Type	1	62-518-32-1X	90	63-35-36-1X	63-19-36-1X	63-15-1-1X
-23	Mack	Pull Type	1	62-518-32-1X	46A	63-35-36-1X	63-19-36-1X	63-15-1-1X
-24	DSD	Pull Type	1	62-518-32-1X	94	63-35-36-1X	63-19-36-1X	63-15-1-1X
-25	Mack	Pull Type	1	62-518-32-1X	46A	63-35-36-1X	63-19-36-1X	63-15-1-1X
-26	Pem Fab	Pull Type	1	62-518-32-1X	90	63-35-36-1X	63-19-36-1X	63-15-1-1X
-27	Am. LaFrance	Push Type	2	62-518-29-1X	113	63-35-36-1X	63-19-30-3-1X	63-15-1-1X
-28	Mack	Pull Type	1	62-518-32-1X	46A	63-35-36-1X	63-19-36-1X	63-15-1-1X
-29	Volvo GM	Pull Type	2	62-518-29-1X	—	63-35-36-1X	63-19-36-1X	63-15-1-1X
-30	Gillig Corp.	Pull Type	2	62-518-29-1X	46A	63-35-36-1X	63-19-36-1X	63-15-1-1X
-31	Mack	Pull Type	1	62-518-32-1X	46A	63-35-36-1X	63-19-36-1X	63-15-1-1X
-32	Pemberton Fab.	Pull Type	1	62-518-32-1X	90	63-35-36-1X	63-19-36-1X	63-15-1-1X
-33	Service	Push Type	1	62-518-32-1X	114A	63-35-36-1X	63-19-30-3-1X	63-15-1-1X
-34	Ontario Buss	Pull Type	2	62-518-29-1X	90	63-35-36-1X	63-19-36-1X	63-15-1-1X
-35	Peter Pirsch & Sons	Pull Type	2	62-518-29-1X	83	63-35-36-1X	63-19-36-1X	63-15-1-1X
-36	Ford	Pull Type	2	62-518-30-1X	—	63-35-36-1X	63-19-36-1X	63-15-15-1X
-37*	Amer. Hoist	Pull Type	—	—	—	63-35-36-1X	63-19-36-1X	63-15-1-1X
-38	Spicer U.K.	Pull Type	1	62-518-32-1X	90	63-35-36-1X	63-19-36-1X	63-15-1-1X
-39**	Gillig Corp.	Pull Type	2	62-518-29-1X	91A	63-35-36-1X	63-19-36-1X	63-15-1-1X
-40**	Gillig Corp.	Pull Type	2	62-518-29-1X	—	63-35-36-1X	63-19-36-1X	63-15-1-1X
-41	Hahn Motors	Pull Type	1	62-518-32-1X	90	63-35-36-1X	63-19-36-1X	63-15-1-1X
-42*	Amer. Hoist	Pull Type	1	62-518-32-1X	59	63-35-36-1X	63-19-36-1X	63-15-1-1X
-43*	Amer. Hoist	Pull Type	1	62-518-32-1X	59	63-35-36-1X	63-19-36-1X	63-15-1-1X
-44	Trencor-Jetco	Pull Type	1	62-518-32-1X	90	63-35-36-1X	63-19-36-1X	63-15-1-1X

### Model CM6253A

**301259**

-1	Service	Pull Type	2	62-518-29-1X	—	63-35-35-1X	63-19-36-1X	63-15-1-1X
-2	GMC	Push Type	2	312098X	—	63-35-50-1X	63-19-30-2-1X	63-15-1-1X
-3	GMC	Pull Type	2	62-518-31-1X	—	63-35-35-1X	63-19-36-1X	63-15-1-1X
-4	Never Released for Production							
-5	S. Madil Ltd.	Pull Type	2	62-518-29-1X	—	63-35-35-1X	63-19-36-1X	63-15-1-1X

§ Short Box

\* Transmission is unsynchronized and 5th speed is blocked out.

\*\* Transmission has special Synchronizers

PARTS LISTED IN THIS CATALOG MAY NO LONGER BE AVAILABLE, USE WITH TRANSMISSION SUPERSEDING LIST.



Tab No.	Mainshaft Rear Bearing Cap Assembly H-1 (incl. Bushing, Seal)	SPEEDOMETER		End Yoke or Companion Flange Page 16	SHIFTER		
		Drive Gear or Signal Gear B-24	Driven Gear H-7		Housing Ass'y Pages 12-13	Lever & Dome Ass'y Page 17	Remote Control Pages 14-15
<b>Model CM6252B (Cont'd)</b>							
<b>301258</b>							
-11	63-19-27-2X	—	—	6-1-2221	63-16-1-1X	—	47-16-8-4X
-12	63-19-6-2X	62-452-3	62-453-5	5-1-3141	63-16-3-1X	—	47-16-8-2X
-13	63-19-6-2X	62-452-3	62-453-4	5-1-3141	63-16-3-1X	—	47-16-8-2X
-14	63-19-6-2X	62-452-3	62-453-5	6-1-2221	63-16-3-1X	—	47-16-8-2X
-15	63-19-6-2X	—	—	—	63-16-1-1X	—	—
-16	63-19-6-2X	62-452-3	62-453-5	6-1-2221	63-16-1-1X	—	47-16-8-2X
-17	63-19-27-2X	—	—	5-4-1661	63-16-3-2X	47-16-5-9X	—
-18	63-19-27-2X	—	—	5-4-1661	63-16-1-1X	—	47-16-8-2X
-19	63-19-27-2X	—	—	6-4-2361	63-16-3-2X	47-16-5-9X	—
-20	63-19-6-2X	62-452-3	62-453-5	6-1-2221	63-16-1-1X	—	311656-11X
-21	63-19-6-2X	—	—	—	—	—	—
-22	63-19-6-2X	62-452-3	62-453-5	6-4-2361	63-16-1-1X	—	47-16-8-2X
-23	63-19-27-2X	—	—	5-4-1661	63-16-1-1X	—	47-16-8-4X
-24	63-19-6-2X	—	—	5-1-3141	63-16-3-1X	—	47-16-8-2X
-25	63-19-27-2X	—	—	6-4-2361	63-16-1-1X	—	47-16-8-4X
-26	63-19-6-2X	—	—	5-1-3141	63-16-3-1X	—	47-16-8-2X
-27	63-19-6-2X	—	—	—	63-16-3-1X	—	47-16-8-2X
-28	63-19-27-2X	—	—	6-4-2361	63-16-3-2X	—	47-16-8-2X
-29	63-19-6-2X	—	—	—	63-16-1-1X	—	—
-30	63-19-6-2X	—	—	5-1-3141	63-16-1-1X	—	47-16-10-4 X
-31	63-19-27-2X	—	—	5-4-1661	63-16-3-2X	—	47-16-8-2X
-32	63-19-6-2X	62-452-13	62-453-10	6-1-2221	63-16-3-1X	—	47-16-8-2X
-33	63-19-27-2X	—	—	5-4-1661	63-16-1-1X	—	47-16-9-3X
-34	63-19-6-2X	62-452-3	62-453-5	5-1-3141	63-16-3-1X	—	47-16-9-3X
-35	63-19-27-2X	62-452-3	62-453-5	6-1-2221	63-16-3-1X	—	47-16-8-3X
-36	63-19-32-1X	—	—	—	63-16-1-1X	—	—
-37	63-19-27-2X	—	—	5-1-3141	63-16-9-2X	47-16-3-25X	—
-38	63-19-6-2X	62-452-13	62-453-10	6-1-2221	63-16-1-1X	—	47-16-8-3X
-39	63-19-6-2X	—	—	5-1-3141	63-16-1-1X	—	47-16-8-3X
-40	63-19-6-2X	—	—	—	63-16-1-1X	—	—
-41	63-19-6-2X	62-452-3	62-453-5	6-1-2221	63-16-3-1X	—	—
-42	63-19-27-2X	—	—	5-1-3141	63-16-3-4X	—	—
-43	63-19-27-2X	—	—	5-1-3141	63-16-9-2X	47-16-3-25X	—
-44	63-19-6-2X	—	—	6-1-2221	63-16-1-4X	—	—

**Model CM6253A**

**301259**

-1	63-19-6-2X	62-452-3	62-453-4	6-4-2361	63-16-1-1X	—	—
-2	63-19-6-2X	62-452-9	—	—	63-16-9-1X	—	—
-3	63-19-6-2X	62-452-9	—	—	63-16-9-1X	—	—
-4	Never Released for Production						
-5	63-19-6-2X	—	—	5-4-1661	63-16-1-1X	—	47-16-8-2X

# MODEL CM60

**SPICER®**



**T210-CM60**

## TABULATED BILLS OF MATERIAL

Tab No.	Used By	For Use With Clutch	CLUTCH HOUSING			Main Drive Gear A-1	Drive Gear Bearing Cap F-2	Case Assembly G-1
			S A E	Assembly No.	Rel. Code Pages 18-19			
<b>Model CM6253A (Cont'd)</b>								
<b>301259</b>								
-6	Never Released for Production							
-7	Ward LaFrance	Pull Type	1	62-518-32-1X	94	63-35-35-1X	63-19-36-1X	63-15-1-1X
-8§	GMC	Pull Type	—	—	—	63-35-50-1X	63-19-30-2-1X	63-15-1-1X
-9	Navistar	Pull Type	1	62-518-32-1X	—	63-35-35-1X	63-19-36-1X	63-15-1-1X
-10§	GMC	Pull Type	—	—	—	63-35-35-1X	63-19-36-1X	63-15-1-1X
-11	FWD Corp.	Pull Type	1	62-518-32-1X	90	63-35-35-1X	63-19-36-1X	63-15-1-1X
-12	Gradall Co.	Push Type	2	62-518-29-1X	46	63-35-35-1X	63-19-30-3-1X	63-15-1-1X
-13§	DSD	Push Type	—	—	—	63-35-35-1X	63-19-30-3-1X	63-15-1-1X
-14	Service	Pull Type	1	62-518-32-1X	—	63-35-35-1X	63-19-36-1X	63-15-1-1X
-15	GMC	Push Type	—	—	—	63-35-50-1X	63-19-30-2-1X	63-15-1-1X
-16	Never Released for Production							
-17	Mack	Pull Type	1	62-518-32-1X	46A	63-35-35-1X	63-19-36-1X	63-15-1-1X
-18	Am. LaFrance	Push Type	2	62-518-29-1X	113	63-35-35-1X	63-19-30-3-1X	63-15-1-1X
-19	Mack	Pull Type	2	62-518-29-1X	—	63-35-35-1X	63-19-36-1X	63-15-1-1X
-20	DSD	Push Type	2	62-518-29-1X	43	63-35-35-1X	63-19-30-3-1X	63-15-1-1X
-21	Hahn Motors	Pull Type	1	62-518-32-1X	90	63-35-35-1X	63-19-36-1X	63-15-1-1X
-22***	DSD	Pull Type	2	62-518-29-1X	84	63-35-35-1X	63-19-36-1X	63-15-1-1X
-23****	DSD	Pull Type	2	62-518-29-1X	62	63-35-35-1X	63-19-36-1X	63-15-1-1X
-24	Am. LaFrance	Push Type	1	62-518-32-1X	—	63-35-35-1X	63-19-30-3-1X	63-15-1-1X
-25	FWD Corp.	Pull Type	2	62-518-29-1X	90	63-35-35-1X	63-19-36-1X	63-15-1-1X
-26	Navistar	Pull Type	2	62-518-29-1X	—	63-35-35-1X	63-19-36-1X	63-15-1-1X
-27	Mack	Pull Type	1	62-518-32-1X	46A	63-35-35-1X	63-19-36-1X	63-15-1-1X
<b>Model CM6253B</b>								
<b>301260</b>								
-1	Service	Pull Type	2	62-518-29-1X	—	63-35-36-1X	63-19-36-1X	63-15-1-1X
-2	Ward LaFrance	Push Type	1	62-518-32-1X	46	63-35-36-1X	63-19-30-3-1X	63-15-1-1X
-3	Am. LaFrance	Push Type	1	62-518-32-1X	113	63-35-36-1X	63-19-30-3-1X	63-15-1-1X
-4	Hendrickson	Pull Type	2	62-518-29-1X	84	63-35-36-1X	63-19-36-1X	63-15-1-1X
-5	FWD Corp.	Pull Type	1	62-518-32-1X	90	63-35-36-1X	63-19-36-1X	63-15-1-1X
-6	FWD Corp.	Pull Type	2	62-518-29-1X	90	63-35-36-1X	63-19-36-1X	63-15-1-1X
-7	Hahn Motors	Pull Type	1	62-518-32-1X	90	63-35-36-1X	63-19-36-1X	63-15-1-1X
-8**	Peter Pirsh	Pull Type	2	62-518-29-1X	83	63-35-36-1X	63-19-36-1X	63-15-1-1X
-9	DSD	Pull Type	2	62-518-29-1X	92A	63-35-36-1X	63-19-36-1X	63-15-1-1X
-10	Hahn Motors	Pull Type	2	62-518-29-1X	90	63-35-36-1X	63-19-36-1X	63-15-1-1X
-11	Hahn Motors	Pull Type	2	62-518-29-1X	90	63-35-36-1X	63-19-36-1X	63-15-1-1X
-12	Never Released for Production							
-13	Service	Pull Type	2	62-518-29-1X	90	63-35-36-1X	63-19-36-1X	63-15-1-1X
-14	Never Released for Production							
-15§	DSD	Push Type	—	—	—	63-35-36-1X	63-19-30-3-1X	63-15-1-1X

§ Short Box

\*\* Transmission has special Synchronizers

\*\*\* Transmission is less 4th Speed Gear and 4th/5th Synchronizer

\*\*\*\*Transmission has Rev., 4th and 5th Speeds blocked out.

PARTS LISTED IN THIS CATALOG MAY NO LONGER BE AVAILABLE, USE WITH TRANSMISSION SUPERSEDING LIST.



Tab No.	Mainshaft Rear Bearing Cap Assembly H-1 (incl. Bushing, Seal)	SPEEDOMETER		End Yoke or Companion Flange Page 16	SHIFTER		
		Drive Gear or Signal Gear B-24	Driven Gear H-7		Housing Ass'y Pages 12-13	Lever & Dome Ass'y Page 17	Remote Control Pages 14-15

**Model CM6253A (Cont'd)**

**301259**

-6	Never Released for Production						
-7	63-19-6-2X	62-452-9	62-453-8	6-1-2221	63-16-3-1X	—	47-16-8-2X
-8	63-19-6-2X	—	—	—	—	—	—
-9	63-19-10-2X	63-452-1	—	—	63-16-1-2X	—	—
-10	63-19-6-2X	—	—	—	—	—	—
-11	63-19-6-2X	—	—	—	63-16-1-1X	—	—
-12	63-19-6-2X	—	—	5-4-1661	63-16-1-1X	—	47-16-8-3X
-13	63-19-6-2X	—	—	—	—	—	—
-14	63-19-10-2X	63-452-1	—	—	63-16-3-6X	—	—
-15	63-19-6-2X	—	—	—	63-16-9-1X	—	—
-16	Never Released for Production						
-17	63-19-27-2X	—	—	6-1-2221	63-16-1-1X	—	47-16-8-4X
-18	63-19-6-2X	—	—	—	63-16-3-1X	—	47-16-8-2X
-19	63-19-6-2X	—	—	—	63-16-1-1X	—	—
-20	63-19-6-2X	—	—	5-1-3151	63-16-1-1X	47-16-3-1X	—
-21	63-19-6-2X	62-452-3	62-453-5	6-1-2221	63-16-3-1X	—	47-16-8-2X
-22	63-19-6-2X	—	—	5-4-1661	63-16-1-1X	47-16-3-1X	—
-23	63-19-10-2X	—	—	6-1-2221	63-16-3-7X	47-16-5-21X	—
-24	63-19-6-2X	—	—	—	63-16-3-1X	—	47-16-8-2X
-25	63-19-6-2X	—	—	—	63-16-1-1X	—	—
-26	63-19-10-2X	63-452-1	—	—	63-16-1-2X	—	—
-27	63-19-27-2X	—	—	5-1-3141	63-16-1-1X	—	47-16-8-4X

**Model CM6253B**

**301260**

-1	63-19-6-2X	62-452-3	62-453-4	6-4-2361	63-16-1-1X	—	—
-2	63-19-6-2X	—	—	—	63-16-3-1X	—	47-16-8-2X
-3	63-19-6-2X	—	—	—	63-16-3-1X	—	47-16-8-2X
-4	63-19-6-2X	62-452-2	—	—	63-16-1-1X	—	47-16-8-2X
-5	63-19-6-2X	—	—	—	63-16-1-1X	—	—
-6	63-19-6-2X	—	—	—	63-16-1-1X	—	—
-7	63-19-6-2X	62-452-3	62-453-5	6-1-2221	63-16-3-1X	—	47-16-8-2X
-8	63-19-27-2X	62-452-3	62-453-3	6-1-2221	63-16-3-1X	—	47-16-8-3X
-9	63-19-6-2X	—	—	—	63-16-3-1X	—	47-16-8-2X
-10	63-19-6-2X	62-452-2	62-452-1	5-1-3141	63-16-3-1X	—	47-16-8-2X
-11	63-19-6-2X	62-452-3	62-453-4	6-1-2221	63-16-3-1X	—	47-16-8-2X
-12	Never Released for Production						
-13	63-19-6-2X	62-452-3	62-453-4	6-1-2221	63-16-1-1X	—	47-16-8-2X
-14	Never Released for Production						
-15	63-19-6-2X	—	—	—	—	—	—

# MODEL CM60

SPICER®



T210-CM60

## TABULATED BILLS OF MATERIAL

Tab No.	Used By	For Use With Clutch	CLUTCH HOUSING			Main Drive Gear A-1	Drive Gear Bearing Cap F-2	Case Assembly G-1
			S A E	Assembly No.	Rel. Code Pages 18-19			
<b>Model CM6253B (Cont'd)</b>								
<b>301260</b>								
-16	Ward LaFrance	Pull Type	1	62-518-32-1X	94	63-35-36-1X	63-19-36-1X	63-15-1-1X
-17	Gradall Co.	Pull Type	2	62-518-29-1X	90	63-35-36-1X	63-19-36-1X	63-15-1-1X
-18	Gradall Co.	Push Type	2	62-518-29-1X	46	63-35-36-1X	63-19-30-3-1X	63-15-1-1X
-19	Gradall Co.	Push Type	2	62-518-29-1X	46	63-35-36-1X	63-19-30-3-1X	63-15-1-1X
-20	GMC	Pull Type	2	62-518-31-1X	—	63-35-36-1X	63-19-36-1X	63-15-1-1X
-21	GMC	Pull Type	2	62-518-29-1X	—	63-35-36-1X	63-19-36-1X	63-15-1-1X
-22	Koehring Co.	Pull Type	2	62-518-29-1X	84	63-35-36-1X	63-19-36-1X	63-15-1-1X
-23	Am. LaFrance	Push Type	2	62-518-29-1X	113	63-35-36-1X	63-19-30-3-1X	63-15-1-1X
-24	Spartan Motors	Pull Type	2	62-518-29-1X	88	63-35-36-1X	63-19-36-1X	63-15-1-1X
-25	Koehring Co.	Push Type	2	62-518-29-1X	39	63-35-36-1X	63-19-30-3-1X	63-15-1-1X
-26	DWT	Pull Type	2	62-518-29-1X	84	63-35-36-1X	63-19-36-1X	63-15-1-1X
-27	Peter Pirsch	Pull Type	2	62-518-29-1X	83	63-35-36-1X	63-19-36-1X	63-15-1-1X
-28	W.H. Mfg. Co.	Push Type	2	62-518-29-1X	113	63-35-36-1X	63-19-30-3-1X	63-15-1-1X
-29	Hahn Motors	Pull Type	1	62-518-32-1X	90	63-35-36-1X	63-19-36-1X	63-15-1-1X
-30	Gradall Co.	Pull Type	2	62-518-29-1X	92A	63-35-36-1X	63-19-36-1X	63-15-1-1X
-31	Ford	Pull Type	2	62-518-29-1X	—	63-35-36-1X	63-19-36-1X	63-15-15-1X
<b>Model CM6052A</b>								
<b>301413</b>								
-1	Service	Pull Type	2	62-518-29-1X	—	63-35-34-1X	63-19-36-1X	63-15-1-1X
-2	Service	Pull Type	2	62-518-29-1X	—	63-35-34-1X	63-19-36-1X	63-15-1-1X
-3	Service	Push Type	2	62-518-27-1X	—	63-35-45-1X	63-19-31-1X	63-15-1-1X
-4	Never Released for Production							
-5	Never Released for Production							
-6	Navistar	Push Type	—	—	—	63-35-48-1X	63-19-22-1X	63-15-1-1X
-7	Never Released for Production							
-8	Harnischfeger	Push Type	2	62-518-29-1X	42	63-35-34-1X	63-19-30-3-1X	63-15-1-1X
-9	Never Released for Production							
-10	Never Released for Production							
-11	Never Released for Production							
-12	Never Released for Production							
-13	Never Released for Production							
-14	Never Released for Production							
-15	Never Released for Production							
-16	Volvo GM	Pull Type	2	62-518-29-1X	—	63-35-34-1X	63-19-36-1X	63-15-1-1X
-17	Cooper Inds.	Pull Type	2	62-518-29-1X	84	63-35-34-1X	63-19-36-1X	63-15-1-1X
-18	GMC	Push Type	—	—	—	63-35-34-1X	63-19-30-3-1X	63-15-1-1X
-19	GMC	Push Type	2	312098X	—	63-35-47-1X	63-19-30-2-1X	63-15-1-1X
-20	Western Star	Push Type	2	62-518-29-1X	—	63-35-34-1X	63-19-30-3-1X	63-15-1-1X

§ Short Box

★ Includes 313263X Neutral Start Switch Actuator Kit

■ Transmission has 3918-68 Independent Remote Control

\*\* Transmission has special Synchronizers

PARTS LISTED IN THIS CATALOG MAY NO LONGER BE AVAILABLE, USE WITH TRANSMISSION SUPERSEDING LIST.





Tab No.	Mainshaft Rear Bearing Cap Assembly H-1 (incl. Bushing, Seal)	SPEEDOMETER		End Yoke or Companion Flange Page 16	SHIFTER		
		Drive Gear or Signal Gear B-24	Driven Gear H-7		Housing Ass'y Pages 12-13	Lever & Dome Ass'y Page 17	Remote Control Pages 14-15
<b>Model CM6253B (Cont'd)</b>							
<b>301260</b>							
-16	63-19-6-2X	62-452-9	62-453-8	6-1-2221	63-16-3-1X	—	47-16-8-2X
-17	63-19-6-2X	—	—	—	63-16-3-1X	—	47-16-8-2X
-18	63-19-6-2X	—	—	5-4-1661	63-16-1-1X	—	47-16-8-3X
-19	63-19-6-2X	—	—	—	63-16-1-1X	—	—
-20	63-19-6-2X	62-452-9	—	—	63-16-9-1X	—	—
-21	63-19-6-2X	62-452-9	62-453-8	6-4-2361	63-16-1-1X	—	47-16-8-3X
-22	63-19-6-2X	—	—	—	63-16-1-1X	—	47-16-8-2X
-23	63-19-6-2X	—	—	—	63-16-3-1X	—	47-16-8-2X
-24	63-19-6-2X	62-452-3	62-453-5	6-1-2221	63-16-1-1X	—	47-16-8-2X
-25	63-19-6-2X	—	—	—	63-16-1-1X	—	47-16-8-2X
-26	63-19-6-2X	62-452-3	62-453-5	5-4-1661	63-16-1-1X	47-16-3-1X	—
-27	63-19-27-2X	62-452-3	62-453-3	6-1-2221	63-16-3-1X	47-16-3-1X	—
-28	63-19-6-2X	—	—	4-1-3781	63-16-3-1X	47-16-3-1X	—
-29	63-19-6-2X	62-452-3	62-453-5	6-1-2221	63-16-3-1X	—	—
-30	63-19-6-2X	—	—	5-4-1661	63-16-1-1X	—	—
-31	63-19-38-1X	—	—	—	63-16-1-1X	—	—
<b>Model CM6052A</b>							
<b>301413</b>							
-1	63-19-6-2X	62-452-3	62-453-4	6-4-2361	63-16-1-1X	—	—
-2	63-19-6-2X	62-452-3	62-453-4	6-4-2361	63-16-3-1X	—	—
-3	63-19-6-2X	62-452-3	62-453-4	6-4-2361	63-16-3-1X	—	—
-4	Never Released for Production						
-5	Never Released for Production						
-6	63-19-10-2X	63-452-1	—	—	63-16-1-2X	—	—
-7	Never Released for Production						
-8	63-19-6-2X	—	—	5-4-1661	63-16-3-5X	—	47-16-8-2X
-9	Never Released for Production						
-10	Never Released for Production						
-11	Never Released for Production						
-12	Never Released for Production						
-13	Never Released for Production						
-14	Never Released for Production						
-15	Never Released for Production						
-16	63-19-6-2X	—	—	—	63-16-1-1X	—	—
-17	63-19-6-2X	—	—	6-1-2221	63-16-3-1X	47-16-3-1X	—
-18	63-19-6-2X	—	—	—	—	—	—
-19	63-19-6-2X	62-452-9	—	—	63-16-9-1X	—	—
-20	63-19-6-2X	—	—	—	63-16-3-1X	—	—

# MODEL CM60

SPICER®



T210-CM60

## TABULATED BILLS OF MATERIAL

Tab No.	Used By	For Use With Clutch	CLUTCH HOUSING			Main Drive Gear A-1	Drive Gear Bearing Cap F-2	Case Assembly G-1
			S A E	Assembly No.	Rel. Code Pages 18-19			
<b>Model CM6052A (Cont'd)</b>								
<b>301413</b>								
-21§	GMC	Push Type	—	—	—	63-35-47-1X	63-19-30-2-1X	63-15-1-1X
-22	Kenworth	Pull Type	2	62-518-29-1X	84	63-35-34-1X	63-19-36-1X	63-15-1-1X
-23	Never Released for Production							
-24	Spartan Motors	Pull Type	2	62-518-29-1X	88	63-35-34-1X	63-19-36-1X	63-15-1-1X
-25	Navistar	Pull Type	2	62-518-29-1X	—	63-35-34-1X	63-19-36-1X	63-15-1-1X
-26	DSD	Pull Type	2	62-518-29-1X	80	63-35-34-1X	63-19-36-1X	63-15-1-1X
-27	DSD	Pull Type	1	62-518-32-1X	59	63-35-34-1X	63-19-36-1X	63-15-1-1X
-28	Cooper Mfg.	Pull Type	1	62-518-32-1X	80	63-35-34-1X	63-19-36-1X	63-15-1-1X
-29	Cooper Mfg.	Pull Type	1	62-518-32-1X	80	63-35-34-1X	63-19-36-1X	63-15-1-1X
-30	Navistar	Pull Type	2	62-518-29-1X	—	63-35-34-1X	63-19-36-1X	63-15-1-1X
-31	Spartan Motors	Push Type	2	62-518-29-1X	22	63-35-34-1X	63-19-30-3-1X	63-15-1-1X
-32	GMC	Push Type	2	312098X	—	63-35-47-1X	63-19-30-2-1X	63-15-1-1X
-33	DWT	Pull Type	—	—	—	63-35-34-1X	63-19-36-1X	63-15-1-1X
-34§	DWT	Push Type	—	—	—	63-35-45-1X	63-19-31-1X	63-15-1-1X
-35§	DWT	Push Type	—	—	—	63-35-34-1X	63-19-30-3-1X	63-15-1-1X
-36	Hendrickson	Pull Type	2	62-518-29-1X	84	63-35-34-1X	63-19-36-1X	63-15-1-1X
-37	Navistar	Pull Type	—	—	—	63-35-34-1X	63-19-36-1X	63-15-1-1X
-38	GMC	Push Type	—	—	—	63-35-34-1X	63-19-30-3-1X	63-15-1-1X
-39	Navistar	Push Type	2	73-518-3	—	63-35-48-1X	63-19-22-1X	63-15-1-1X
-40	Scot Truck Ltd.	Pull Type	1	62-518-32-1X	—	63-35-34-1X	63-19-36-1X	63-15-1-1X
-41	Am. LaFrance	Push Type	1	62-518-32-1X	113	63-35-34-1X	63-19-30-3-1X	63-15-1-1X
-42	Cooper Mfg.	Pull Type	—	—	—	63-35-34-1X	63-19-36-1X	63-15-1-1X
-43	Cooper Mfg.	Pull Type	2	62-518-29-1X	—	63-35-34-1X	63-19-36-1X	63-15-1-1X
-44	S. Madill Ltd.	Pull Type	2	62-518-29-1X	84	63-35-34-1X	63-19-36-1X	63-15-1-1X
-45	Bissinger/Stein	Pull Type	2	62-518-29-1X	80	63-35-34-1X	63-19-36-1X	63-15-1-1X
-46	Whicita Eng.	Pull Type	2	62-518-27-1X	15	63-35-45-1X	63-19-36-1X	63-15-1-1X
-47	Never Released for Production							
-48	Navistar	Push Type	2	73-518-3	—	63-35-48-1X	63-19-22-1X	63-15-1-1X
-49	Never Released for Production							
-50	Navistar	Pull Type	2	62-518-29-1X	—	63-35-57-1X	63-19-36-1X	63-15-1-1X
-51★	DWT	Pull Type	1	63-518-32-1X	79	63-35-34-1X	63-19-36-1X	63-15-1-1X
-52	Gillig Corp.	Pull Type	2	62-518-29-1X	68	63-35-34-1X	63-19-36-1X	63-15-1-1X
-53	Gillig Corp.	Pull Type	2	62-518-29-1X	90	63-35-34-1X	63-19-36-1X	63-15-1-1X
-54	Cooper Mfg.	Pull Type	1	62-518-32-1X	84	63-35-34-1X	63-19-36-1X	63-15-1-1X
-55	Mack	Pull Type	1	62-518-32-1X	—	63-35-34-1X	63-19-36-1X	63-15-1-1X
-56	Navistar	Pull Type	2	62-518-29-1X	—	63-35-57-1X	63-19-36-1X	63-15-1-1X
-57	Volvo GM	Pull Type	2	62-518-29-1X	—	63-35-34-1X	63-19-36-1X	63-15-1-1X
-58	GMC	Pull Type	2	62-518-31-1X	—	63-35-34-1X	63-19-36-1X	63-15-1-1X
-59	Cooper Mfg.	Pull Type	2	62-518-29-1X	84	63-35-34-1X	63-19-36-1X	63-15-1-1X
-60	Cooper Mfg.	Pull Type	1	62-518-32-1X	84	63-35-34-1X	63-19-36-1X	63-15-1-1X

§ Short Box

★ Transmission includes 3918-12 Independent Remote Control

PARTS LISTED IN THIS CATALOG MAY NO LONGER BE AVAILABLE, USE WITH TRANSMISSION SUPERSEDING LIST.



# MODEL CM60

## TABULATED BILLS OF MATERIAL

T210-CM60

Tab No.	Mainshaft Rear Bearing Cap Assembly H-1 (incl. Bushing, Seal)	SPEEDOMETER		End Yoke or Companion Flange Page 16	SHIFTER		
		Drive Gear or Signal Gear B-24	Driven Gear H-7		Housing Ass'y Pages 12-13	Lever & Dome Ass'y Page 17	Remote Control Pages 14-15
<b>Model CM6052A (Cont'd)</b>							
<b>301413</b>							
-21	63-19-6-2X	—	—	—	—	—	—
-22	63-19-6-2X	62-452-3	62-453-5	6-4-2361	63-16-1-1X	47-16-3-3X	—
-23	Never Released for Production						
-24	63-19-6-2X	62-452-3	62-453-5	5-1-3141	63-16-1-1X	—	47-16-8-2X
-25	63-19-8-2X	63-452-1	—	—	63-16-1-2X	—	—
-26	63-19-6-2X	—	—	4-1-3781	63-16-3-1X	47-16-3-1X	—
-27	63-19-6-2X	—	—	5-1-3141	63-16-3-1X	—	47-16-8-2X
-28	63-19-6-2X	62-452-3	62-453-4	6-1-2221	63-16-3-1X	—	—
-29	63-19-6-2X	62-452-3	62-453-4	6-1-2221	63-16-3-1X	47-16-3-1X	—
-30	63-19-10-2X	63-452-1	—	—	63-16-1-2X	—	—
-31	63-19-6-2X	62-452-3	62-453-5	5-1-3141	63-16-1-1X	—	47-16-8-2X
-32	63-19-6-2X	62-452-9	—	5-4-1661	63-16-9-1X	—	—
-33	63-19-6-2X	—	—	—	63-16-1-2X	—	—
-34	63-19-6-2X	—	—	—	—	—	—
-35	63-19-6-2X	—	—	—	—	—	—
-36	63-19-6-2X	62-452-2	—	5-4-1661	63-16-3-1X	—	47-16-8-2X
-37	63-19-10-2X	63-452-1	—	—	63-16-1-2X	—	—
-38	63-19-6-2X	—	—	—	63-16-9-1X	—	—
-39	63-19-10-2X	63-452-1	—	—	63-16-1-2X	—	—
-40	63-19-6-2X	62-452-3	62-453-5	6-4-2361	63-16-3-2X	—	—
-41	63-19-6-2X	—	—	—	63-16-3-1X	—	47-16-8-2X
-42	63-16-6-2X	—	—	—	63-16-1-1X	47-16-3-1X	—
-43	63-19-6-2X	—	—	—	63-16-1-1X	—	47-16-8-2X
-44	63-19-6-2X	—	—	5-4-1661	63-16-1-1X	—	47-16-8-2X
-45	63-19-6-2X	—	—	—	63-16-3-1X	47-16-3-1X	—
-46	63-19-6-2X	—	—	—	63-16-3-1X	47-16-3-1X	—
-47	Never Released for Production						
-48	63-19-8-2X	63-452-1	—	—	63-16-1-2X	—	—
-49	Never Released for Production						
-50	63-19-10-2X	63-452-1	—	—	63-16-1-2X	—	—
-51	63-19-6-2X	—	—	6-1-2221	63-16-3-1X	—	47-16-8-2X
-52	63-19-6-2X	—	—	5-1-3141	63-16-3-1X	—	47-16-8-5X
-53	63-19-6-2X	62-452-3	62-453-4	—	63-16-3-1X	—	47-16-8-2X
-54	63-19-6-2X	—	—	6-1-2221	63-16-3-1X	47-16-3-1X	—
-55	63-19-6-2X	—	—	—	63-16-1-1X	—	—
-56	63-19-8-2X	63-452-1	—	—	63-16-1-2X	—	—
-57	63-19-6-2X	62-452-3	—	—	63-16-1-1X	—	—
-58	63-19-6-2X	62-452-9	—	—	63-16-9-1X	—	—
-59	63-19-6-2X	—	—	6-1-2221	63-16-1-1X	47-16-3-1X	—
-60	63-19-6-2X	—	—	6-1-2221	63-16-1-1X	47-16-3-1X	—

# MODEL CM60

**SPICER®**



**T210-CM60**

## TABULATED BILLS OF MATERIAL

Tab No.	Used By	For Use With Clutch	CLUTCH HOUSING			Main Drive Gear A-1	Drive Gear Bearing Cap F-2	Case Assembly G-1
			S A E	Assembly No.	Rel. Code Pages 18-19			
<b>Model CM6052A (Cont'd)</b>								
<b>301413</b>								
-61	Ford	Push Type	—	—	—	63-35-38-1X	63-19-20-1X	63-15-11-1X
-62	Ford	Push Type	—	—	—	63-35-38-1X	63-19-20-1X	63-15-11-1X
-63	Ford	Push Type	2	313243	—	63-35-37-1X	63-19-21-1X	63-15-15-1X
-64	Ford	Push Type	2	313243	—	63-35-37-1X	63-19-21-1X	63-15-15-1X
-65	Gradall Co.	Push Type	2	62-518-27-1X	43	63-35-45-1X	63-19-31-1X	63-15-1-1X
-66	Bissinger/Stein	Pull Type	2	62-518-29-1X	80	63-35-34-1X	63-19-36-1X	63-15-1-1X
-67	Ford	Pull Type	2	62-518-30-1X	—	63-35-34-1X	63-19-36-1X	63-15-15-1X
-68	Ford	Pull Type	2	62-518-30-1X	—	63-35-34-1X	63-19-36-1X	63-15-15-1X
-69	Ford	Pull Type	2	62-518-30-1X	—	63-35-34-1X	63-19-36-1X	63-15-15-1X
-70	Ford	Pull Type	2	62-518-30-1X	—	63-35-34-1X	63-19-36-1X	63-15-15-1X
-71	DSD	Pull Type	2	62-518-29-1X	84	63-35-34-1X	63-19-36-1X	63-15-1-1X
-72	GMC	Push Type	2	312098X	—	63-35-47-1X	63-19-30-2-1X	63-15-1-1X
-73	Ford	Pull Type	2	62-518-29-1X	—	63-35-34-1X	63-19-36-1X	63-15-15-1X
-74	Ford	Pull Type	2	62-518-29-1X	—	63-35-34-1X	63-19-36-1X	63-15-15-1X
-75	Diesel Equip.	Pull Type	2	62-518-29-1X	84	63-35-34-1X	63-19-36-1X	63-15-1-1X
-76	Bissinger/Stein	Pull Type	1	62-518-32-1X	80	63-35-34-1X	63-19-36-1X	63-15-1-1X
-77	Diesel Equip.	Pull Type	1	62-518-32-1X	84	63-35-34-1X	63-19-36-1X	63-15-1-1X
-78	Wich-Tex	Pull Type	1	62-518-32-1X	84	63-35-34-1X	63-19-36-1X	63-15-1-1X
-79	GMC	Pull Type	2	62-518-29-1X	—	63-35-34-1X	63-19-36-1X	63-15-1-1X
-80	Intl. Petroleum	Pull Type	2	62-518-29-1X	80	63-35-34-1X	63-19-36-1X	63-15-1-1X
-81	Blue Bird Body	Push Type	2	62-518-29-1X	56	63-35-34-1X	63-19-30-3-1X	63-15-1-1X
-82	DSD	Push Type	2	62-518-27-1X	—	63-35-45-1X	63-19-31-1X	63-15-1-1X
-83	Volvo GM	Pull Clutch	2	62-518-29-1X	—	63-35-34-1X	63-19-36-1X	63-15-1-1X
-84	DSD	Push Type	—	—	—	63-35-37-1X	63-19-21-1X	63-15-15-1X
-85	Service	Pull Type	2	62-518-29-1X	15A	63-35-57-1X	63-19-36-1X	63-15-1-1X
-86	Cooper Mfg.	Pull Type	1	62-518-32-1X	59	63-35-34-1X	63-19-36-1X	63-15-1-1X
-87	Hendrickson	Pull Type	2	62-518-29-1X	84	63-35-34-1X	63-19-36-1X	63-15-1-1X
-88	Trenco-Jetco	Pull Type	1	62-518-32-1X	59	63-35-34-1X	63-19-36-1X	63-15-1-1X
-89	DSD	Pull Type	—	—	—	63-35-57-1X	63-19-36-1X	63-15-1-1X
-90	DSD	Pull Type	—	—	—	63-35-34-1X	63-19-36-1X	63-15-15-1X
-91	FWD Corp	Pull Type	2	62-518-29-1X	91	63-35-34-1X	63-19-36-1X	63-15-1-1X
-92	GMC	Push Type	1	62-518-32-1X	—	63-35-34-1X	63-19-30-3-1X	63-15-1-1X
-93	GMC	Push Type	2	62-518-29-1X	—	63-35-34-1X	63-19-30-3-1X	63-15-1-1X
-94	Ford	Push Type	2	62-518-29-1X	—	63-35-34-1X	63-19-30-3-1X	63-15-1-1X
-95	Ford	Push Type	2	313243	—	63-35-37-1X	63-19-21-1X	63-15-15-1X
-96	Ford	Pull Type	2	62-518-29-1X	—	63-35-34-1X	63-19-36-1X	63-15-15-1X
-97	Ford	Pull Type	2	62-518-29-1X	—	63-35-34-1X	63-19-36-1X	63-15-15-1X
-98	Pierce Mfg.	Pull Type	2	62-518-29-1X	84	63-35-34-1X	63-19-36-1X	63-15-1-1X
-99	Gillig Corp.	Pull Type	2	62-518-29-1X	91	63-35-34-1X	63-19-36-1X	63-15-1-1X
-100	Ford	Push Type	2	313243	—	63-35-37-1X	63-19-21-1X	63-15-15-1X

◀ Includes 97-454-2-1X consisting of (1) 97-454-2 Speedo Sleeve and (1) 97-463-34 Seal

PARTS LISTED IN THIS CATALOG MAY NO LONGER BE AVAILABLE, USE WITH TRANSMISSION SUPERSEDING LIST.



# MODEL CM60

## TABULATED BILLS OF MATERIAL

T210-CM60

Tab No.	Mainshaft Rear Bearing Cap Assembly H-1 (incl. Bushing, Seal)	SPEEDOMETER			End Yoke or Companion Flange Page 16	SHIFTER		
		Drive Gear or Signal Gear B-24	Driven Gear H-7			Housing Ass'y Pages 12-13	Lever & Dome Ass'y Page 17	Remote Control Pages 14-15
<b>Model CM6052A (Cont'd)</b>								
<b>301413</b>								
-61	63-19-38-1X	—	—	—	63-16-1-1X	—	—	—
-62	63-19-33-2X	—	—	—	63-16-1-1X	—	—	—
-63	63-19-38-1X	—	—	—	63-16-1-1X	—	—	—
-64	63-19-33-2X	—	—	—	63-16-1-1X	—	—	—
-65	63-19-6-2X	—	—	5-4-1661	63-16-1-1X	—	—	47-16-8-3X
-66	63-19-6-2X	—	—	4-1-3781	63-16-3-1X	—	—	47-16-8-2X
-67	63-19-38-1X	—	—	—	63-16-1-1X	—	—	—
-68	63-19-33-2X	—	—	—	63-16-1-1X	—	—	—
-69	63-19-38-1X	—	—	—	63-16-3-2X	—	—	—
-70	63-19-33-2X	—	—	—	63-16-3-2X	—	—	—
-71	63-19-6-2X	62-452-3	62-453-5	5-4-1661	63-16-1-1X	—	—	47-16-8-2X
-72	63-19-37-2X	62-452-9	—	—	63-16-9-1X	—	—	—
-73	63-19-38-1X	—	—	—	63-16-1-1X	—	—	—
-74	63-19-33-2X	—	—	—	63-16-1-1X	—	—	—
-75	63-19-6-2X	—	—	—	63-16-1-1X	47-16-3-1X	—	—
-76	63-19-6-2X	—	—	4-1-3781	63-16-3-1X	—	—	47-16-8-2X
-77	63-19-6-2X	—	—	5-1-3141	63-16-1-1X	47-16-3-1X	—	—
-78	63-19-6-2X	—	—	—	63-16-1-1X	47-16-3-1X	—	—
-79	63-19-37-2X	62-452-9	—	—	63-16-9-1X	—	—	—
-80	63-19-6-2X	—	—	5-1-3141	63-16-3-1X	47-16-3-1X	—	—
-81	63-19-6-2X	62-452-3	62-453-4	—	63-16-1-1X	—	—	—
-82	63-19-6-2X	62-452-3	62-453-4	5-4-1661	63-16-1-1X	—	—	—
-83	63-19-6-2X	62-452-3	—	—	63-16-1-1X	—	—	—
-84	63-19-38-1X	—	—	—	63-16-1-1X	—	—	—
-85	63-19-6-2X	53-452-4	53-453-2	6-4-2361	63-16-1-1X	—	—	47-16-8-3X
-86	63-19-6-2X	—	—	6-1-2221	63-16-1-1X	47-16-3-1X	—	—
-87	63-19-6-2X	62-452-2	—	—	63-16-1-1X	—	—	47-16-8-2X
-88	63-19-6-2X	—	—	5-1-3141	63-16-3-1X	47-16-5-22X	—	—
-89	63-19-10-2X	63-452-1	—	—	63-16-1-2X	—	—	—
-90	63-19-38-1X	—	—	—	63-16-1-1X	—	—	—
-91	63-19-6-2X	—	—	—	63-16-1-1X	—	—	—
-92	63-19-6-2X	62-452-9	—	—	63-16-9-1X	—	—	—
-93	63-19-6-2X	62-452-9	—	—	63-16-9-1X	—	—	—
-94	63-19-37-2X	62-452-9	—	—	63-16-9-1X	—	—	—
-95	63-19-38-1X	63-452-3	—	5-4-7041-1	63-16-1-1X	—	—	—
-96	63-19-38-1X	63-452-3	—	5-4-7041-1	63-16-1-1X	—	—	—
-97	63-19-38-1X	63-452-3	—	6-4-3831-1	63-16-1-1X	—	—	—
-98	63-19-6-2X	62-452-9	62-453-8	6-4-2361	63-16-1-1X	—	—	—
-99	63-19-6-2X	—	—	5-1-3141	63-16-1-1X	—	—	—
-100	63-19-38-1X	63-452-3	—	6-4-3831-1	63-16-1-1X	—	—	—

# MODEL CM60

**SPICER®**



**T210-CM60**

## TABULATED BILLS OF MATERIAL

Tab No.	Used By	For Use With Clutch	CLUTCH HOUSING			Main Drive Gear A-1	Drive Gear Bearing Cap F-2	Case Assembly G-1
			S A E	Assembly No.	Rel. Code Pages 18-19			
<b>Model CM6052A (Cont'd)</b>								
<b>301413</b>								
-101	GMC	Push Type	2	62-518-31-1X	—	63-35-34-1X	63-19-30-3-1X	63-15-1-1X
-102	DWT	Push Type	2	62-518-30-1X	22	63-35-34-1X	63-19-30-3-1X	63-15-1-1X
-103	Cummins-China	Pull Type	2	62-518-29-1X	93	63-35-34-1X	63-19-36-1X	63-15-1-1X
-104	Blue Bird Body	Pull Type	2	62-518-29-1X	78A	63-35-34-1X	63-19-36-1X	63-15-1-1X
<b>Model CM6052B</b>								
<b>301414</b>								
-1	Service	Pull Type	2	62-518-29-1X	—	63-35-34-1X	63-19-36-1X	63-15-1-1X
-2	Navistar	Push Type	—	—	—	63-35-48-1X	63-19-22-1X	63-15-1-1X
-3 thru -9	Never Released for Production							
-10	DSD	Pull Type	1	62-518-32-1X	84	63-35-34-1X	63-19-36-1X	63-15-1-1X
-11	Tidd-Todd Ltd.	Pull Type	1	62-518-32-1X	90	63-35-34-1X	63-19-36-1X	63-15-1-1X
-12§	GMC	Push Type	—	—	—	63-35-47-1X	63-19-30-2-1X	63-15-1-1X
-13	Ward LaFrance	Pull Type	1	62-518-32-1X	94	63-35-34-1X	63-19-36-1X	63-15-1-1X
-14	Never Released for Production							
-15	Bombardier Inc.	Push Type	2	62-518-27-1X	39	63-35-45-1X	63-19-31-1X	63-15-1-1X
-16	DSD	Pull Type	2	62-518-29-1X	94	63-35-34-1X	63-19-36-1X	63-15-1-1X
-17§	DSD	Push Type	—	—	—	63-35-45-1X	63-19-31-1X	63-15-1-1X
-18§	DSD	Push Type	—	—	—	63-35-34-1X	63-19-30-3-1X	63-15-1-1X
-19	GMC	Push Type	2	312098X	—	63-35-47-1X	63-19-30-2-1X	63-15-1-1X
-20	Can. Foremost	Push Type	2	62-518-27-1X	45	63-35-45-1X	63-19-31-1X	63-15-1-1X
-21	GMC	Push Type	—	—	—	63-35-47-1X	63-19-30-2-1X	63-15-1-1X
-22	GMC	Push Type	—	—	—	63-35-47-1X	63-19-30-2-1X	63-15-1-1X
-23	Mack	Pull Type	1	62-518-32-1X	46A	63-35-34-1X	63-19-36-1X	63-15-1-1X
-24	Navistar	Pull Type	2	62-518-29-1X	—	63-35-34-1X	63-19-36-1X	63-15-1-1X
-25	DWT	Pull Type	2	62-518-29-1X	84	63-35-34-1X	63-19-36-1X	63-15-1-1X
-26	DWT	Push Type	2	62-518-27-1X	57	63-35-45-1X	63-19-31-1X	63-15-1-1X
-27	FWD Corp.	Push Type	2	62-518-27-1X	45	63-35-45-1X	63-19-31-1X	63-15-1-1X
-28	FWD Corp.	Push Type	2	62-518-27-1X	45	63-35-45-1X	63-19-31-1X	63-15-1-1X
-29	Never Released for Production							
-30	Mack	Pull Type	2	62-518-36-1X	—	63-35-34-1X	63-19-36-1X	63-15-1-1X
-31	Kenworth	Pull Type	1	62-518-32-1X	64	63-35-34-1X	63-19-36-1X	63-15-1-1X
-32	GMC	Pull Type	2	62-518-31-1X	—	63-35-34-1X	63-19-36-1X	63-15-1-1X
-33	Navistar	Pull Type	2	62-518-29-1X	—	63-35-57-1X	63-19-36-1X	63-15-1-1X
-34	DWT	Push Type	2	62-518-29-1X	44	63-35-34-1X	63-19-30-3-1X	63-15-1-1X
-35	Navistar	Pull Type	2	62-518-29-1X	—	63-35-57-1X	63-19-36-1X	63-15-1-1X
-36	Gillig Corp.	Pull Type	1	62-518-32-1X	68	63-35-34-1X	63-19-36-1X	63-15-1-1X
-37	Navistar	Pull Type	2	62-518-29-1X	—	63-35-34-1X	63-19-36-1X	63-15-1-1X
-38	Am. LaFrance	Push Type	1	62-518-32-1X	113	63-35-34-1X	63-19-30-3-1X	63-15-1-1X
-39★	Thos. Built Buss	Pull Type	2	62-518-29-1X	75	63-35-34-1X	63-19-36-1X	63-15-1-1X
-40	Spartan Motors	Pull Type	2	62-518-29-1X	88	63-35-34-1X	63-19-36-1X	63-15-1-1X
-41	Ford	Pull Type	2	62-518-30-1X	—	63-35-34-1X	63-19-36-1X	63-15-15-1X

§ Short Box

★ Includes 313263X Neutral Start Switch Acuator Kit

PARTS LISTED IN THIS CATALOG MAY NO LONGER BE AVAILABLE, USE WITH TRANSMISSION SUPERSEDING LIST.



Tab No.	Mainshaft Rear Bearing Cap Assembly H-1 (incl. Bushing, Seal)	SPEEDOMETER		End Yoke or Companion Flange Page 16	SHIFTER		
		Drive Gear or Signal Gear B-24	Driven Gear H-7		Housing Ass'y Pages 12-13	Lever & Dome Ass'y Page 17	Remote Control Pages 14-15
<b>Model CM6052A (Cont'd)</b>							
<b>301413</b>							
-101	63-19-6-2X	62-452-9	—	—	63-16-9-1X	—	—
-102	63-19-6-2X	62-452-3	62-453-5	4-1-3781	63-16-1-1X	—	47-16-9-3X
-103	63-19-6-2X	62-452-3	62-453-4	6-1-2221	63-16-1-1X	47-16-5-22X	—
-104	63-19-6-2X	62-452-3	62-453-4	—	63-16-1-2X	—	—
<b>Model CM6052B</b>							
<b>301414</b>							
-1	63-19-6-2X	62-452-3	62-453-4	6-4-2361	63-16-1-1X	—	—
-2	63-19-10-2X	63-452-1	—	—	63-16-1-2X	—	—
-3 thru -9	Never Released for Production						
-10	63-19-6-2X	62-452-3	62-453-4	5-4-1661	63-16-1-1X	47-16-3-1X	—
-11	63-19-6-2X	—	—	5-1-3141	63-16-3-1X	—	47-16-8-2X
-12	63-19-6-2X	—	—	—	—	—	—
-13	63-19-6-2X	62-452-9	62-453-8	6-1-2221	63-16-3-1X	—	47-16-8-2X
-14	Never Released for Production						
-15	63-19-6-2X	—	—	5-1-3141	63-16-1-1X	—	47-16-8-2X
-16	63-19-6-2X	62-452-3	62-453-5	—	63-16-3-1X	47-16-3-1X	—
-17	63-19-6-2X	—	—	—	—	—	—
-18	63-19-6-2X	—	—	—	—	—	—
-19	63-19-6-2X	62-452-9	—	—	63-16-9-1X	—	—
-20	63-19-6-2X	62-452-2	62-452-1	4-1-3781	63-16-3-1X	—	47-16-8-2X
-21	63-19-37-2X	—	—	—	63-16-9-1X	—	—
-22	63-19-6-2X	—	—	—	63-16-9-1X	—	—
-23	63-19-27-2X	—	—	6-4-2361	63-16-3-2X	47-16-5-9X	—
-24	63-19-10-2X	63-452-1	—	—	63-16-1-2X	—	—
-25	63-19-6-2X	62-452-3	62-453-5	6-1-2221	63-16-3-1X	47-16-3-1X	—
-26	63-19-6-2X	62-452-3	62-453-5	4-1-3781	63-16-3-1X	47-16-3-1X	—
-27	63-19-6-2X	—	—	—	63-16-1-1X	—	47-16-8-2X
-28	63-19-6-2X	—	—	—	63-16-1-1X	—	47-16-8-2X
-29	Never Released for Production						
-30	63-19-6-2X	—	—	—	63-16-1-1X	—	—
-31	63-19-6-2X	62-452-3	62-453-5	6-4-2361	63-16-1-1X	47-16-3-1X	—
-32	63-19-6-2X	62-452-9	—	—	63-16-9-1X	—	—
-33	63-19-8-2X	63-452-1	—	—	63-16-1-2X	—	—
-34	63-19-6-2X	62-452-3	63-453-4	—	63-16-3-1X	—	47-16-8-2X
-35	63-19-10-2X	63-452-1	—	—	63-16-1-2X	—	—
-36	63-19-6-2X	—	—	5-1-3141	63-16-3-1X	—	47-16-8-5X
-37	63-19-8-2X	63-452-1	—	—	63-16-1-2X	—	—
-38	63-19-6-2X	—	—	—	63-16-3-1X	—	47-16-8-2X
-39	63-19-6-2X	—	—	5-4-1661	63-16-1-1X	—	47-16-9-2X
-40	63-19-6-2X	—	—	6-1-2221	63-16-1-1X	—	47-16-8-3X
-41	63-19-38-1X	63-452-2	63-453-1	6-4-3831	63-16-1-1X	—	—

# MODEL CM60

**SPICER®**



**T210-CM60**

## TABULATED BILLS OF MATERIAL

Tab No.	Used By	For Use With Clutch	CLUTCH HOUSING			Main Drive Gear A-1	Drive Gear Bearing Cap F-2	Case Assembly G-1
			S A E	Assembly No.	Rel. Code Pages 18-19			
<b>Model CM6052B (Cont'd)</b>								
<b>301414</b>								
-42	Ford	Push Type	2	313243	—	63-35-37-1X	63-19-21-1X	63-15-15-1X
-43	Ford	Pull Type	2	62-518-30-1X	—	63-35-34-1X	63-19-36-1X	63-15-15-1X
-44	Ford	Pull Type	2	62-518-30-1X	—	63-35-34-1X	63-19-36-1X	63-15-15-1X
-45	Ford	Pull Type	2	62-518-30-1X	—	63-35-34-1X	63-19-36-1X	63-15-15-1X
-46	Ford	Pull Type	2	62-518-30-1X	—	63-35-34-1X	63-19-36-1X	63-15-15-1X
-47	Simon-Duplex	Pull Type	2	62-518-29-1X	84	63-35-34-1X	63-19-36-1X	63-15-1-1X
-48	Ford	Pull Type	2	62-518-29-1X	—	63-35-34-1X	63-19-36-1X	63-15-15-1X
-49	Ford	Push Type	2	313243	—	63-35-37-1X	63-19-21-1X	63-15-15-1X
-50	Spicer U.K.	Push Type	1	62-518-32-1X	112A	63-35-34-1X	63-19-30-3-1X	63-15-1-1X
-51	Ford	Pull Type	2	62-518-29-1X	—	63-35-34-1X	63-19-36-1X	63-15-15-1X
-52	DWT	Pull Type	2	62-518-27-1X	15B	63-35-45-1X	63-19-36-1X	63-15-1-1X
-53▶	Capitol Trencher	Push Type	—	—	—	63-35-38-1X	63-19-20-1X	63-15-11-1X
-54	Osterlund Corp.	Pull Type	2	62-518-29-1X	—	63-35-34-1X	63-19-36-1X	63-15-1-1X
-55	Blue Bird Body	Push Type	2	62-518-29-1X	56	63-35-34-1X	63-19-30-3-1X	63-15-1-1X
-56★	Thos. Built Buss	Pull Type	2	62-518-29-1X	75	63-35-34-1X	63-19-36-1X	63-15-1-1X
-57	Service	Push Type	2	62-518-29-1X	39	63-35-34-1X	63-19-30-3-1X	63-15-1-1X
-58	Service	Push Type	2	62-518-29-1X	39	63-35-34-1X	63-19-30-3-1X	63-15-1-1X
-59	DSD	Push Type	—	—	—	63-35-37-1X	63-19-21-1X	63-15-15-1X
-60	Gradall Co.	Push Type	2	62-518-27-1X	43	63-35-45-1X	63-19-31-1X	63-15-1-1X
-61	Ford	Pull Type	2	62-518-29-1X	—	63-35-34-1X	63-19-36-1X	63-15-15-1X
-62	Ford	Pull Type	2	62-518-29-1X	—	63-35-34-1X	63-19-36-1X	63-15-15-1X
-63	Gradall Co.	Pull Type	2	62-518-29-1X	90	63-35-57-1X	63-19-36-1X	63-15-1-1X
-64■	Cummins-China	Pull Type	2	62-518-29-1X	93	63-35-34-1X	63-19-36-1X	63-15-1-1X
-65★	Thos. Built Buss	Push Type	2	62-518-29-1X	35A	63-35-34-1X	63-19-30-3-1X	63-15-1-1X
-66◀	TSP	Pull Type	2	62-518-29-1X	90	63-35-57-1X	63-19-36-1X	63-15-1-1X
-67◀	TSP	Pull Type	2	62-518-29-1X	90	63-35-57-1X	63-19-36-1X	63-15-1-1X

### Model CM6052C

**301415**

-1	Service	Pull Type	2	62-518-29-1X	—	63-35-46-1X	63-19-36-1X	63-15-1-1X
-2	Never Released for Production							
-3	Navistar	Pull Type	—	—	—	63-35-46-1X	63-19-36-1X	63-15-1-1X
-4	Never Released for Production							
-5	Never Released for Production							
-6	Am. LaFrance	Push Type	2	62-518-29-1X	113	63-35-46-1X	63-19-30-3-1X	63-15-1-1X
-7	GMC	Push Type	2	312098X	—	63-35-52-1X	63-19-30-2-1X	63-15-1-1X
-8	GMC	Pull Type	2	62-518-31-1X	—	63-35-46-1X	63-19-36-1X	63-15-1-1X
-9	Never Released for Production							
-10	Never Released for Production							

- ★ Includes 313263X Neutral Start Switch Acuator Kit
- Unit includes 3918-107 Independent Remote Control
- ◀ Includes 97-454-2-1X consisting of (1) 97-454-2 Speedo Sleeve and (1) 97-463-34 Seal
- ▶ Unit is less Synchronizers

PARTS LISTED IN THIS CATALOG MAY NO LONGER BE AVAILABLE, USE WITH TRANSMISSION SUPERSEDING LIST.





# MODEL CM60

## TABULATED BILLS OF MATERIAL

T210-CM60

Tab No.	Mainshaft Rear Bearing Cap Assembly H-1 (Incl. Bushing, Seal)	SPEEDOMETER		End Yoke or Companion Flange Page 16	SHIFTER		
		Drive Gear or Signal Gear B-24	Driven Gear H-7		Housing Ass'y Pages 12-13	Lever & Dome Ass'y Page 17	Remote Control Pages 14-15
<b>Model CM6052B (Cont'd)</b>							
<b>301414</b>							
-42	63-19-38-1X	—	—	—	63-16-1-1X	—	—
-43	63-19-38-1X	—	—	—	63-16-1-1X	—	—
-44	63-19-33-2X	—	—	—	63-16-1-1X	—	—
-45	63-19-33-2X	—	—	—	63-16-1-1X	—	—
-46	63-19-33-2X	—	—	—	63-16-3-2X	—	—
-47	63-19-6-2X	62-452-3	62-453-4	6-1-2221	63-16-3-1X	—	—
-48	63-19-38-1X	—	—	—	63-16-1-1X	—	—
-49	63-19-33-2X	—	—	—	63-16-1-1X	—	—
-50	63-19-6-2X	—	—	5-1-3141	63-16-3-1X	—	47-16-8-2X
-51	63-19-33-2X	—	—	—	63-16-1-1X	—	—
-52	63-19-6-2X	62-452-3	62-453-5	5-4-1661	63-16-1-1X	47-16-3-1X	—
-53	63-19-38-1X	—	—	—	63-16-1-1X	—	—
-54	63-19-6-2X	62-452-3	62-453-4	6-4-2361	63-16-1-1X	47-16-3-1X	—
-55	63-19-6-2X	62-452-3	62-453-4	—	63-16-1-1X	—	—
-56	63-19-6-2X	—	—	5-4-1661	63-16-1-1X	—	—
-57	63-19-6-2X	62-452-3	62-453-4	5-4-1661	63-16-1-1X	—	—
-58	63-19-6-2X	62-452-3	62-453-4	5-4-1661	63-16-1-1X	—	—
-59	63-19-38-1X	—	—	—	63-16-3-2X	—	—
-60	63-19-6-2X	—	—	5-4-1661	63-16-1-1X	—	—
-61	63-19-38-1X	63-452-3	—	5-4-7041-1	63-16-1-1X	—	—
-62	63-19-38-1X	63-452-3	—	6-4-3831-1	63-16-1-1X	—	—
-63	63-19-6-2X	—	—	5-4-1661	63-16-1-1X	—	—
-64	63-19-6-2X	62-452-3	62-453-4	6-1-2221	63-16-1-1X	—	47-16-8-3X
-65	63-19-42-2X	63-452-4	—	5-4-1661	63-16-1-1X	—	—
-66	63-19-6-2X	62-452-3	62-453-4	6-4-2361	63-16-3-1X	47-16-5-22X	—
-67	63-19-6-2X	62-452-3	62-453-4	6-4-2361	63-16-1-1X	47-16-5-22X	—

**Model CM6052C**

**301415**

-1	63-19-6-2X	62-452-3	62-453-4	6-4-2361	63-16-1-1X	—	—
-2	Never Released for Production						
-3	63-19-10-2X	63-452-1	—	—	63-16-1-2X	—	—
-4	Never Released for Production						
-5	Never Released for Production						
-6	63-19-6-2X	—	—	—	63-16-3-1X	—	47-16-8-2X
-7	63-19-6-2X	62-452-9	—	—	63-16-9-1X	—	—
-8	63-19-6-2X	62-452-9	—	—	63-16-9-1X	—	—
-9	Never Released for Production						
-10	Never Released for Production						

# MODEL CM60

**SPICER®**



**T210-CM60**

## TABULATED BILLS OF MATERIAL

Tab No.	Used By	For Use With Clutch	CLUTCH HOUSING			Main Drive Gear A-1	Drive Gear Bearing Cap F-2	Case Assembly G-1
			S A E	Assembly No.	Rel. Code Pages 18-19			
<b>Model CM6052C (Cont'd)</b>								
<b>301415</b>								
-11	■ Omnibus	Pull Type	2	62-518-29-1X	90	63-35-46-1X	63-19-36-1X	63-15-1-1X
-12	Never Released for Production							
-13	Volvo GM	Push Type	2	62-518-29-1X	—	63-35-46-1X	63-19-30-3-1X	63-15-1-1X
-14	Western Star	Pull Type	2	62-518-29-1X	—	63-35-46-1X	63-19-36-1X	63-15-1-1X
-15§	GMC	Pull Type	—	—	—	63-35-52-1X	63-19-30-2-1X	63-15-1-1X
-16§	GMC	Pull Type	—	—	—	63-35-46-1X	63-19-36-1X	63-15-1-1X
-17§	Volvo GM	Pull Type	—	—	—	63-35-46-1X	63-19-36-1X	63-15-1-1X
-18	Mack	Pull Type	1	62-518-32-1X	—	63-35-46-1X	63-19-36-1X	63-15-1-1X
-19	Never Released for Production							
-20	Never Released for Production							
-21	DSD	Pull Type	1	62-518-32-1X	84	63-35-46-1X	63-19-36-1X	63-15-1-1X
-22	Navistar	Pull Type	1	62-518-32-1X	—	63-35-46-1X	63-19-36-1X	63-15-1-1X
-23	Never Released for Production							
-24§	DSD	Push Type	—	—	—	63-35-46-1X	63-19-30-3-1X	63-15-1-1X
-25	DSD	Push Type	—	—	—	63-35-39-1X	63-19-21-1X	63-15-1-1X
-26	Navistar	Push Type	2	73-518-3	—	63-35-49-1X	63-19-22-1X	63-15-1-1X
-27	GMC	Push Type	—	—	—	63-35-52-1X	63-19-30-2-1X	63-15-1-1X
-28	GMC	Push Type	2	312098X	—	63-35-52-1X	63-19-30-2-1X	63-15-1-1X
-29	DSD	Push Type	2	62-518-29-1X	43	63-35-46-1X	63-19-30-3-1X	63-15-1-1X
-30	Never Released for Production							
-31	Geo. Space Co.	Pull Type	1	62-518-32-1X	90	63-35-46-1X	63-19-36-1X	63-15-1-1X
-32	Never Released for Production							
-33	Navistar	Pull Type	2	62-518-29-1X	—	63-35-56-1X	63-19-36-1X	63-15-1-1X
-34	Navistar	Pull Type	2	62-518-29-1X	—	63-35-56-1X	63-19-36-1X	63-15-1-1X
-35	Am. LaFrance	Push Type	1	62-518-32-1X	113	63-35-46-1X	63-19-30-3-1X	63-15-1-1X
-36	Navistar	Pull Type	2	62-518-29-1X	—	63-35-46-1X	63-19-36-1X	63-15-1-1X
-37	GMC	Pull Type	2	62-518-31-1X	—	63-35-46-1X	63-19-36-1X	63-15-1-1X
-38	Never Released for Production							
-39	Ford	Push Type	—	—	—	63-35-40-1X	63-19-20-1X	63-15-11-1X
-40	Ford	Push Type	—	—	—	63-35-40-1X	63-19-20-1X	63-15-11-1X
-41	Ford	Push Type	2	313243	—	63-35-39-1X	63-19-21-1X	63-15-15-1X
-42	Ford	Push Type	2	313243	—	63-35-39-1X	63-19-21-1X	63-15-15-1X
-43	Ford	Pull Type	2	62-518-30-1X	—	63-35-46-1X	63-19-36-1X	63-15-15-1X
-44	Ford	Pull Type	2	62-518-30-1X	—	63-35-46-1X	63-19-36-1X	63-15-15-1X
-45	Ford	Pull Type	2	62-518-30-1X	—	63-35-46-1X	63-19-36-1X	63-15-15-1X
-46	Ford	Pull Type	2	62-518-30-1X	—	63-35-46-1X	63-19-36-1X	63-15-15-1X
-47	Never Released for Production							
-48	Ford	Pull Type	2	62-518-29-1X	—	63-35-46-1X	63-19-36-1X	63-15-15-1X
-49	Ford	Pull Type	2	62-518-29-1X	—	63-35-46-1X	63-19-36-1X	63-15-15-1X
-50	GMC	Push Type	2	62-518-29-1X	—	63-35-46-1X	63-19-30-3-1X	63-15-1-1X

§ Short Box

■ Unit includes 3918-6 Independent Remote Control

PARTS LISTED IN THIS CATALOG MAY NO LONGER BE AVAILABLE, USE WITH TRANSMISSION SUPERSEDING LIST.



# MODEL CM60

## TABULATED BILLS OF MATERIAL

T210-CM60

Tab No.	Mainshaft Rear Bearing Cap Assembly H-1 (incl. Bushing, Seal)	SPEEDOMETER		End Yoke or Companion Flange Page 16	SHIFTER		
		Drive Gear or Signal Gear B-24	Driven Gear H-7		Housing Ass'y Pages 12-13	Lever & Dome Ass'y Page 17	Remote Control Pages 14-15
<b>Model CM6052C (Cont'd)</b>							
<b>301415</b>							
-11	63-19-27-2X	62-452-2	62-452-1	6-4-2361	63-16-1-1X	—	47-16-8-2X
-12	Never Released for Production						
-13	63-19-6-2X	—	—	—	63-16-3-1X	—	—
-14	63-19-6-2X	—	—	—	63-16-3-1X	—	—
-15	63-19-6-2X	—	—	—	—	—	—
-16	63-19-6-2X	—	—	—	—	—	—
-17	63-19-6-2X	—	—	—	—	—	—
-18	63-19-6-2X	—	—	—	63-16-1-1X	—	—
-19	Never Released for Production						
-20	Never Released for Production						
-21	63-19-6-2X	62-452-3	62-453-4	—	63-16-1-1X	—	—
-22	63-19-10-2X	63-452-1	—	—	63-16-1-2X	—	—
-23	Never Released for Production						
-24	63-19-6-2X	—	—	—	—	—	—
-25	63-19-10-2X	63-452-1	—	—	63-16-1-2X	—	—
-26	63-19-10-2X	63-452-1	—	—	63-16-1-2X	—	—
-27	63-19-6-2X	—	—	—	63-16-9-1X	—	—
-28	63-19-37-2X	62-452-9	—	—	63-16-9-1X	—	—
-29	63-19-6-2X	—	—	6-1-2221	63-16-1-1X	47-16-3-1X	—
-30	Never Released for Production						
-31	63-19-6-2X	—	—	—	63-16-1-1X	—	—
-32	Never Released for Production						
-33	63-19-10-2X	63-452-1	—	—	63-16-1-2X	—	—
-34	63-19-8-2X	63-452-1	—	—	63-16-1-2X	—	—
-35	63-19-6-2X	—	—	—	63-16-3-1X	—	—
-36	63-19-8-2X	63-452-1	—	—	63-16-1-2X	—	—
-37	63-19-6-2X	62-452-9	—	—	63-16-9-1X	—	—
-38	Never Released for Production						
-39	63-19-38-1X	—	—	—	63-16-1-1X	—	—
-40	63-19-33-2X	—	—	—	63-16-1-1X	—	—
-41	63-19-38-1X	—	—	—	63-16-1-1X	—	—
-42	63-19-33-2X	—	—	—	63-16-1-1X	—	—
-43	63-19-38-1X	—	—	—	63-16-1-1X	—	—
-44	63-19-33-2X	—	—	—	63-16-1-1X	—	—
-45	63-19-38-1X	—	—	—	63-16-3-2X	—	—
-46	63-19-33-2X	—	—	—	63-16-3-2X	—	—
-47	Never Released for Production						
-48	63-19-38-1X	—	—	—	63-16-1-1X	—	—
-49	63-19-33-2X	—	—	—	63-16-1-1X	—	—
-50	63-19-6-2X	62-452-9	—	—	63-16-9-1X	—	—

# MODEL CM60

**SPICER®**



**T210-CM60**

## TABULATED BILLS OF MATERIAL

Tab No.	Used By	For Use With Clutch	CLUTCH HOUSING			Main Drive Gear A-1	Drive Gear Bearing Cap F-2	Case Assembly G-1
			S A E	Assembly No.	Rel. Code Pages 18-19			
<b>Model CM6052C (Cont'd)</b>								
<b>301415</b>								
-51	GMC	Push Type	2	312098X	—	63-35-52-1X	63-19-30-2-1X	63-15-1-1X
-52	Diesel Equip.	Pull Type	2	62-518-29-1X	84	63-35-46-1X	63-19-36-1X	63-15-1-1X
-53	Ford	Push Type	2	62-518-35-1X	—	63-35-39-1X	63-19-21-1X	63-15-15-1X
-54	GMC	Pull Type	2	62-518-29-1X	—	63-35-46-1X	63-19-36-1X	63-15-1-1X
-55	Am. LaFrance	Pull Type	1	62-518-32-1X	96A	63-35-46-1X	63-19-36-1X	63-15-1-1X
-56	DSD	Push Type	—	—	—	63-35-39-1X	63-19-21-1X	63-15-15-1X
-57	GMC	Push Type	2	62-158-29-1X	—	63-35-46-1X	63-19-30-3-1X	63-15-1-1X
-58	Ford	Push Type	2	313243	—	63-35-39-1X	63-19-21-1X	63-15-15-1X
-59	Ford	Pull Type	2	62-518-29-1X	—	63-35-46-1X	63-19-36-1X	63-15-15-1X
-60	Never Released for Production							
-61	FWD Corp.	Pull Type	2	62-518-29-1X	91	63-35-46-1X	63-19-36-1X	63-15-1-1X
-62	Volvo GM	Pull Type	2	62-518-29-1X	—	63-35-46-1X	63-19-36-1X	63-15-1-1X
-63	GMC	Push Type	2	62-518-31-1X	—	63-35-46-1X	63-19-30-3-1X	63-15-1-1X
-64	Blue Bird	Push Type	2	62-518-92-1X	56	63-35-46-1X	63-19-30-3-1X	63-15-1-1X
<b>Model CM6052D</b>								
<b>301416</b>								
-1	Never Released for Production							
-2	Navistar	Pull Type	2	62-518-29-1X	—	63-35-34-1X	63-19-36-1X	63-15-1-1X
-3	Navistar	Pull Type	2	62-518-29-1X	—	63-35-57-1X	63-19-36-1X	63-15-1-1X
-4	Never Released for Production							
-5	Ford	Pull Type	2	62-518-30-1X	—	63-35-34-1X	63-19-36-1X	63-15-15-1X
-6	Ford	Pull Type	2	62-518-30-1X	—	63-35-34-1X	63-19-36-1X	63-15-15-1X
-7	Ford	Push Type	2	313243	—	63-35-37-1X	63-19-21-1X	63-15-15-1X
-8	Ford	Push Type	2	313243	—	63-35-37-1X	63-19-21-1X	63-15-15-1X
-9	Navistar	Pull Type	2	62-518-29-1X	—	63-35-57-1X	63-19-36-1X	63-15-1-1X
-10	Ford	Pull Type	2	62-518-29-1X	—	63-35-34-1X	63-19-36-1X	63-15-15-1X
-11 thru-15	Never Released for Production							
-16	GMC	Push Type	2	312098X	—	63-35-47-1X	63-19-30-2-1X	63-15-1-1X
-17 thru-18	Never Released for Production							
-19	GMC	Push Type	2	62-518-29-1X	—	63-35-34-1X	63-19-30-3-1X	63-15-1-1X
-20	GMC	Pull Type	2	62-518-31-1X	—	63-35-34-1X	63-19-36-1X	63-15-1-1X
-21	Ford	Push Type	2	313243	—	63-35-37-1X	63-19-21-1X	63-15-15-1X
-22	Ford	Pull Type	2	62-518-29-1X	—	63-35-34-1X	63-19-36-1X	63-15-15-1X
-23	Ford	Pull Type	2	62-518-29-1X	—	63-35-34-1X	63-19-36-1X	63-15-15-1X
-24	Navistar	Pull Type	2	62-518-29-1X	—	63-35-57-1X	63-19-36-1X	63-15-1-1X
-25	Navistar	Pull Type	2	62-518-29-1X	—	63-35-57-1X	63-19-36-1X	63-15-1-1X
<b>Model CM6252B</b>								
<b>301417</b>								
-1	Service	Pull Type	2	62-518-29-1X	—	63-35-36-1X	63-19-36-1X	63-15-1-1X
-2	Am. LaFrance	Push Type	1	62-518-32-1X	113	63-35-36-1X	63-19-30-3-1X	63-15-1-1X
-3 **	Gillig Corp.	Pull Type	2	62-518-29-1X	91	63-35-36-1X	63-19-36-1X	63-15-1-1X
-4	Never Released for Production							
-5	Hendrickson	Pull Type	2	62-518-29-1X	84	63-35-36-1X	63-19-36-1X	63-15-1-1X

\*\* Unit has Special Synchronizers

PARTS LISTED IN THIS CATALOG MAY NO LONGER BE AVAILABLE, USE WITH TRANSMISSION SUPERSEDING LIST.



# MODEL CM60

## TABULATED BILLS OF MATERIAL

T210-CM60

Tab No.	Mainshaft Rear Bearing Cap Assembly H-1 (incl. Bushing, Seal)	SPEEDOMETER		End Yoke or Companion Flange Page 16	SHIFTER		
		Drive Gear or Signal Gear B-24	Driven Gear H-7		Housing Ass'y Pages 12-13	Lever & Dome Ass'y Page 17	Remote Control Pages 14-15
<b>Model CM6052C (Cont'd)</b>							
<b>301415</b>							
-51	63-19-6-2X	62-452-9	—	—	63-16-9-1X	—	—
-52	63-19-6-2X	—	—	—	63-16-1-1X	—	—
-53	63-19-38-1X	—	—	—	63-16-3-2X	—	—
-54	63-19-37-2X	62-452-9	—	—	63-16-9-1X	—	—
-55	63-19-6-2X	—	—	—	63-16-3-1X	—	47-16-8-2X
-56	63-19-38-1X	—	—	—	63-16-1-1X	—	—
-57	63-19-37-2X	62-452-9	—	—	63-16-9-1X	—	—
-58	63-19-38-1X	63-452-3	—	5-4-7041-1	63-16-1-1X	—	—
-59	63-19-38-1X	63-452-3	—	5-4-7041-1	63-16-1-1X	—	—
-60	Never Released for Production						
-61	63-19-6-2X	—	—	—	63-16-1-1X	—	—
-62	63-19-6-2X	62-452-3	—	—	63-16-1-1X	—	—
-63	63-19-6-2X	62-452-9	—	—	63-16-9-1X	—	—
-64	63-19-6-2X	62-452-3	62-453-4	—	63-16-1-1X	—	—
<b>Model CM6052D</b>							
<b>301416</b>							
-1	Never Released for Production						
-2	63-19-10-2X	63-452-1	—	—	63-16-1-2X	—	—
-3	63-19-10-2X	63-452-1	—	—	63-16-1-2X	—	—
-4	Never Released for Production						
-5	63-19-38-1X	—	—	—	63-16-1-1X	—	—
-6	63-19-33-2X	—	—	—	63-16-1-1X	—	—
-7	63-19-38-1X	—	—	—	63-16-1-1X	—	—
-8	63-19-33-2X	—	—	—	63-16-1-1X	—	—
-9	63-19-8-2X	63-452-1	—	—	63-16-1-2X	—	—
-10	63-19-32-2X	—	—	—	63-16-1-1X	—	—
-11 thru-15	Never Released for Production						
-16	63-19-6-2X	62-452-9	—	—	63-16-9-1X	—	—
-17 thru-18	Never Released for Production						
-19	63-19-6-2X	62-452-9	—	—	63-16-9-1X	—	—
-20	63-19-6-2X	62-452-9	—	—	63-16-9-1X	—	—
-21	63-19-38-1X	63-452-3	—	5-4-7041-1	63-16-1-1X	—	—
-22	63-19-38-1X	63-452-3	—	5-4-7041-1	63-16-1-1X	—	—
-23	63-19-38-1X	63-452-3	—	6-4-3831-1	63-16-1-1X	—	—
-24	63-19-42-2X	63-452-4	—	—	63-16-1-2X	—	—
-25	63-19-40-2X	63-452-4	—	—	63-16-1-2X	—	—
<b>Model CM6252B</b>							
<b>301417</b>							
-1	63-19-6-2X	62-452-3	62-453-4	6-4-2361	63-16-1-1X	—	—
-2	63-19-6-2X	—	—	—	63-16-3-1X	—	—
-3	63-19-6-2X	—	—	5-1-3141	63-16-1-1X	—	47-16-8-4X
-4	Never Released for Production						
-5	63-19-6-2X	62-452-2	—	—	63-16-1-1X	—	46-16-8-2X

# MODEL CM60

SPICER®



T210-CM60

## TABULATED BILLS OF MATERIAL

Tab No.	Used By	For Use With Clutch	CLUTCH HOUSING			Main Drive Gear A-1	Drive Gear Bearing Cap F-2	Case Assembly G-1
			S A E	Assembly No.	Rel. Code Pages 18-19			
<b>Model CM6252B (Cont'd)</b>								
<b>301417</b>								
-6	Hahn Motors	Pull Type	1	62-518-32-1X	90	63-35-36-1X	63-19-36-1X	63-15-1-1X
-7*	Amer. Hoist	Pull Type	1	62-518-32-1X	59	63-35-36-1X	63-19-36-1X	63-15-1-1X
-8	Never Released for Production							
-9	Badger Equip.	Pull Type	2	62-518-29-1X	90	63-35-36-1X	63-19-36-1X	63-15-1-1X
-10	Mack	Pull Type	1	62-518-32-1X	46A	63-35-36-1X	63-19-36-1X	63-15-1-1X
-11	Mack	Pull Type	1	62-518-32-1X	46A	63-35-36-1X	63-19-36-1X	63-15-1-1X
-12	Hahn Motors	Pull Type	2	62-518-29-1X	90	63-35-36-1X	63-19-36-1X	63-15-1-1X
-13	Hahn Motors	Pull Type	2	62-518-29-1X	90	63-35-36-1X	63-19-36-1X	63-15-1-1X
-14	Hahn Motors	Pull Type	2	62-518-29-1X	90	63-35-36-1X	63-19-36-1X	63-15-1-1X
-15	FWD Corp.	Pull Type	1	62-518-32-1X	90	63-35-36-1X	63-19-36-1X	63-15-1-1X
-16	Spartan Motors	Pull Type	2	62-518-29-1X	88	63-35-36-1X	63-19-36-1X	63-15-1-1X
-17	Mack	Pull Type	1	62-518-32-1X	46A	63-35-36-1X	63-19-36-1X	63-15-1-1X
-18	Mack	Pull Type	1	62-518-32-1X	46A	63-35-36-1X	63-19-36-1X	63-15-1-1X
-19	Mack	Pull Type	1	62-518-32-1X	46A	63-35-36-1X	63-19-36-1X	63-15-1-1X
-20	Crown Coach	Pull Type	1	62-518-32-1X	86	63-35-36-1X	63-19-36-1X	63-15-1-1X
-21§	DSD	Push Type	—	—	—	63-35-36-1X	63-19-30-3-1X	63-15-1-1X
-22■	Australia	Pull Type	1	62-518-32-1X	84	63-35-36-1X	63-19-36-1X	63-15-1-1X
-23	Mack	Pull Type	1	62-518-32-1X	46A	63-35-36-1X	63-19-36-1X	63-15-1-1X
-24	DSD	Pull Type	1	62-518-32-1X	94	63-35-36-1X	63-19-36-1X	63-15-1-1X
-25	Mack	Pull Type	1	62-518-32-1X	46A	63-35-36-1X	63-19-36-1X	63-15-1-1X
-26	Pemberton Fab.	Pull Type	1	62-518-32-1X	90	63-35-36-1X	63-19-36-1X	63-15-1-1X
-27	Am. LaFrance	Push Type	2	62-518-29-1X	113	63-35-36-1X	63-19-30-3-1X	63-15-1-1X
-28	Mack	Pull Type	1	62-518-32-1X	46A	63-35-36-1X	63-19-36-1X	63-15-1-1X
-29	Volvo GM	Pull Type	2	62-518-29-1X	—	63-35-36-1X	63-19-36-1X	63-15-1-1X
-30**	Gillig Corp.	Pull Type	2	62-518-29-1X	91	63-35-36-1X	63-19-36-1X	63-15-1-1X
-31	Mack	Pull Type	1	62-518-32-1X	46A	63-35-36-1X	63-19-36-1X	63-15-1-1X
-32	Pemberton Fab.	Pull Type	1	62-518-32-1X	90	63-35-36-1X	63-19-36-1X	63-15-1-1X
-33	Service	Push Type	1	62-518-32-1X	114A	63-35-36-1X	63-19-30-3-1X	63-15-1-1X
-34■	Ontario Bus	Pull Type	2	62-518-29-1X	90	63-35-36-1X	63-19-36-1X	63-15-1-1X
-35**	Peter Pirsch	Pull Type	2	62-518-29-1X	83	63-35-36-1X	63-19-36-1X	63-15-1-1X
-36	Ford	Pull Type	2	62-518-30-1X	—	63-35-36-1X	63-19-36-1X	63-15-15-1X
-37*	Amer. Hoist	Pull Type	—	—	—	63-35-36-1X	63-19-36-1X	63-15-1-1X
-38	Spicer U.K.	Pull Type	1	62-518-32-1X	90	63-35-36-1X	63-19-36-1X	63-15-1-1X
-39**	Gillig Corp.	Pull Type	2	62-518-29-1X	91A	63-35-36-1X	63-19-36-1X	63-15-1-1X
-40**	Gillig Corp.	Pull Type	2	62-518-29-1X	—	63-35-36-1X	63-19-36-1X	63-15-1-1X
-41	Hahn Motors	Pull Type	1	62-518-32-1X	90	63-35-36-1X	63-19-36-1X	63-15-1-1X
-42*	Amer. Hoist	Pull Type	1	62-518-32-1X	59	63-35-36-1X	63-19-36-1X	63-15-1-1X
-43*	Amer. Hoist	Pull Type	1	62-518-32-1X	59	63-35-36-1X	63-19-36-1X	63-15-1-1X
-44	Trencor-Jetco	Pull Type	1	62-518-32-1X	90	63-35-36-1X	63-19-36-1X	63-15-1-1X

\* Unit is less Synchronizers with 5th Speed Blocked out.

\*\* Unit has Special Synchronizers

§ Short Box

■ Unit includes Independent Remote Control. 3918-107 on 301417-22 and 3918-68 on 301417-34

PARTS LISTED IN THIS CATALOG MAY NO LONGER BE AVAILABLE, USE WITH TRANSMISSION SUPERSEDING LIST.



# MODEL CM60

## TABULATED BILLS OF MATERIAL

**T210-CM60**

Tab No.	Mainshaft Rear Bearing Cap Assembly H-1 (incl. Bushing, Seal)	SPEEDOMETER		End Yoke or Companion Flange Page 16	SHIFTER		
		Drive Gear or Signal Gear B-24	Driven Gear H-7		Housing Ass'y Pages 12-13	Lever & Dome Ass'y Page 17	Remote Control Pages 14-15
<b>Model CM6252B (Cont'd)</b>							
<b>301417</b>							
-6	63-19-6-2X	62-452-3	62-453-5	6-1-2221	63-16-3-1X	—	47-16-8-2X
-7	63-19-27-2X	—	—	5-1-3141	63-16-3-4X	—	47-16-8-2X
-8	Never Released for Production						
-9	63-19-6-2X	62-452-3	62-453-4	—	63-16-3-1X	—	47-16-8-2X
-10	63-19-27-2X	—	—	5-1-3141	63-16-1-1X	—	47-16-8-4X
-11	63-19-27-2X	—	—	6-1-2221	63-16-1-1X	—	47-16-8-4X
-12	63-19-6-2X	62-452-3	62-453-5	5-1-3141	63-16-3-1X	—	47-16-8-2X
-13	63-19-6-2X	62-452-3	62-453-4	5-1-3141	63-16-3-1X	—	47-16-8-2X
-14	63-19-6-2X	62-452-3	62-453-5	6-1-2221	63-16-3-1X	—	47-16-8-2X
-15	63-19-6-2X	—	—	—	63-16-1-1X	—	—
-16	63-19-6-2X	62-452-3	62-453-5	6-1-2221	63-16-1-1X	—	47-16-8-2X
-17	63-19-27-2X	—	—	5-4-1661	63-16-3-2X	47-16-5-9X	—
-18	63-19-27-2X	—	—	5-4-1661	63-16-1-1X	—	47-16-8-2X
-19	63-19-27-2X	—	—	6-4-2361	63-16-3-2X	47-16-5-9X	—
-20	63-19-6-2X	62-452-3	62-453-5	6-1-2221	63-16-1-1X	—	311656-11X
-21	63-19-6-2X	—	—	—	—	—	—
-22	63-19-6-2X	62-452-3	62-453-5	6-4-2361	63-16-1-1X	—	47-16-8-2X
-23	63-19-27-2X	—	—	5-4-1661	63-16-1-1X	—	47-16-8-4X
-24	63-19-6-2X	—	—	5-1-3141	63-16-3-1X	—	47-16-8-2X
-25	63-19-27-2X	—	—	6-4-2361	63-16-1-1X	—	47-16-8-4X
-26	63-19-6-2X	—	—	5-1-3141	63-16-3-1X	—	47-16-8-2X
-27	63-19-6-2X	—	—	—	63-16-3-1X	—	47-16-8-2X
-28	63-19-27-2X	—	—	6-4-2361	63-16-3-2X	—	47-16-8-2X
-29	63-19-6-2X	—	—	—	63-16-1-1X	—	—
-30	63-19-6-2X	—	—	5-1-3141	63-16-1-1X	—	47-16-10-4X
-31	63-19-27-2X	—	—	5-4-1661	63-16-3-2X	—	47-16-8-2X
-32	63-19-6-2X	62-452-13	62-453-10	6-1-2221	63-16-3-1X	—	47-16-8-2X
-33	63-19-27-2X	—	—	5-4-1661	63-16-1-1X	—	47-16-9-3X
-34	63-19-6-2X	62-452-3	62-453-5	5-1-3141	63-16-3-1X	—	47-16-9-3X
-35	63-19-27-2X	62-452-3	62-453-5	6-1-2221	63-16-3-1X	—	47-16-8-3X
-36	63-19-38-1X	—	—	—	63-16-1-1X	—	—
-37	63-19-27-2X	—	—	5-1-3141	63-16-9-2X	47-16-3-25X	—
-38	63-19-6-2X	62-452-13	62-453-10	6-1-2221	63-16-1-1X	—	47-16-8-3X
-39	63-19-6-2X	—	—	5-1-3141	63-16-1-1X	—	47-16-8-3X
-40	63-19-6-2X	—	—	—	63-16-1-1X	—	—
-41	63-19-6-2X	62-452-3	62-453-5	6-1-2221	63-16-3-1X	—	—
-42	63-19-27-2X	—	—	5-1-3141	63-16-3-4X	—	—
-43	63-19-27-2X	—	—	5-1-3141	63-16-9-2X	47-16-3-25X	—
-44	63-19-6-2X	—	—	6-1-2221	63-16-1-4X	—	—

# MODEL CM60

SPICER®



T210-CM60

## TABULATED BILLS OF MATERIAL

Tab No.	Used By	For Use With Clutch	CLUTCH HOUSING			Main Drive Gear A-1	Drive Gear Bearing Cap F-2	Case Assembly G-1
			S A E	Assembly No.	Rel. Code Pages 18-19			
<b>Model CM6253B</b>								
<b>301418</b>								
-1	Service	Pull Type	2	62-518-29-1X	—	63-35-36-1X	63-19-36-1X	63-15-1-1X
-2	Ward LaFrance	Push Type	1	62-518-32-1X	46	63-35-36-1X	63-19-30-3-1X	63-15-1-1X
-3	Am. LaFrance	Push Type	1	62-518-32-1X	113	63-35-36-1X	63-19-30-3-1X	63-15-1-1X
-4	Hendrickson	Pull Type	2	62-518-29-1X	84	63-35-36-1X	63-19-36-1X	63-15-1-1X
-5	FWD Corp.	Pull Type	1	62-518-32-1X	90	63-35-36-1X	63-19-36-1X	63-15-1-1X
-6	FWD Corp.	Pull Type	2	62-518-29-1X	90	63-35-36-1X	63-19-36-1X	63-15-1-1X
-7	Hahn Motors	Pull Type	1	62-518-32-1X	90	63-35-36-1X	63-19-36-1X	63-15-1-1X
-8	Peter Pirsch	Pull Type	2	62-518-29-1X	83	63-35-36-1X	63-19-36-1X	63-15-1-1X
-9	DSD	Pull Type	2	62-518-29-1X	92A	63-35-36-1X	63-19-36-1X	63-15-1-1X
-10	Hahn Motors	Pull Type	2	62-518-29-1X	90	63-35-36-1X	63-19-36-1X	63-15-1-1X
-11	Hahn Motors	Pull Type	2	62-518-29-1X	90	63-35-36-1X	63-19-36-1X	63-15-1-1X
-12	Never Released for Production							
-13	Service	Pull Type	2	62-518-29-1X	90	63-35-36-1X	63-19-36-1X	63-15-1-1X
-14	Never Released for Production							
-15§	DSD	Push Type	—	—	—	63-35-36-1X	63-19-30-3-1X	63-15-1-1X
-16	Ward LaFrance	Pull Type	1	62-518-32-1X	94	63-35-36-1X	63-19-36-1X	63-15-1-1X
-17	Gradall Co.	Pull Type	2	62-518-29-1X	90	63-35-36-1X	63-19-36-1X	63-15-1-1X
-18	Gradall Co.	Push Type	2	62-518-29-1X	43	63-35-36-1X	63-19-30-3-1X	63-15-1-1X
-19	Gradall Co.	Push Type	2	62-518-29-1X	43	63-35-36-1X	63-19-30-3-1X	63-15-1-1X
-20	GMC	Pull Type	2	62-518-31-1X	—	63-35-36-1X	63-19-36-1X	63-15-1-1X
-21■	GMC	Pull Type	2	62-518-29-1X	—	63-35-36-1X	63-19-36-1X	63-15-1-1X
-22	Koehring Crane	Pull Type	2	62-518-29-1X	84	63-35-36-1X	63-19-36-1X	63-15-1-1X
-23	Am. LaFrance	Push Type	2	62-518-29-1X	113	63-35-36-1X	63-19-30-3-1X	63-15-1-1X
-24	Spartan Motors	Pull Type	2	62-518-29-1X	88	63-35-36-1X	63-19-36-1X	63-15-1-1X
-25★	Koehring Crane	Push Type	2	62-518-29-1X	39	63-35-36-1X	63-19-30-3-1X	63-15-1-1X
-26	DWT	Pull Type	2	62-518-29-1X	84	63-35-36-1X	63-19-36-1X	63-15-1-1X
-27	Peter Pirsch	Pull Type	2	62-518-29-1X	83	63-35-36-1X	63-19-36-1X	63-15-1-1X
-28	W.H. Mfg. Co.	Push Type	2	62-518-29-1X	113	63-35-36-1X	63-19-30-3-1X	63-15-1-1X
-29	Hahn Motors	Pull Type	1	62-518-32-1X	90	63-35-36-1X	63-19-36-1X	63-15-1-1X
-30	Gradall Co.	Pull Type	2	62-518-29-1X	92B	63-35-36-1X	63-19-36-1X	63-15-1-1X
-31	Ford	Pull Type	2	62-518-29-1X	—	63-35-36-1X	63-19-36-1X	63-15-15-1X
-32	Ford	Pull Type	2	62-518-29-1X	—	63-35-36-1X	63-19-36-1X	63-15-15-1X
-33	Ford	Pull Type	2	62-518-29-1X	—	63-35-36-1X	63-19-36-1X	63-15-15-1X
-34◀	Cummins Amer.	Push Type	2	62-518-29-1X	43	63-35-36-1X	63-19-30-3-1X	63-15-1-1X
-35◀	Cummins Amer.	Pull Type	2	62-518-29-1X	92B	63-35-36-1X	63-19-36-1X	63-15-1-1X
-36◀	DWT	Push Type	2	62-518-29-1X	43	63-35-36-1X	63-19-30-3-1X	63-15-1-1X

§ Short Box

■ Unit includes 3918-68 Independent Remote Control

★ Unit includes 313263X Neutral Start Switch Actuator Kit

◀ Unit includes 97-454-2-1X consisting of (1) 97-454-2 Speedo Sleeve and (1) 97-463-34 Seal

PARTS LISTED IN THIS CATALOG MAY NO LONGER BE AVAILABLE, USE WITH TRANSMISSION SUPERSEDING LIST.





# MODEL CM60

## TABULATED BILLS OF MATERIAL

T210-CM60

Tab No.	Mainshaft Rear Bearing Cap Assembly H-1 (incl. Bushing, Seal)	SPEEDOMETER		End Yoke or Companion Flange Page 16	SHIFTER		
		Drive Gear or Signal Gear B-24	Driven Gear H-7		Housing Ass'y Pages 12-13	Lever & Dome Ass'y Page 17	Remote Control Pages 14-15
<b>Model CM6253B</b>							
<b>301418</b>							
-1	63-19-6-2X	62-452-2	62-453-4	6-4-2361	63-16-1-1X	—	—
-2	63-19-6-2X	—	—	—	63-16-3-1X	—	47-16-8-2X
-3	63-19-6-2X	—	—	—	63-16-3-1X	—	47-16-8-2X
-4	63-19-6-2X	62-452-2	—	—	63-16-1-1X	—	47-16-8-2X
-5	63-19-6-2X	—	—	—	63-16-1-1X	—	—
-6	63-19-6-2X	—	—	—	63-16-1-1X	—	—
-7	63-19-6-2X	62-452-3	62-453-5	6-1-2221	63-16-3-1X	—	47-16-8-2X
-8	63-19-27-2X	62-452-3	62-453-3	6-1-2221	63-16-3-1X	—	47-16-8-3X
-9	63-19-6-2X	—	—	—	63-16-3-1X	—	47-16-8-2X
-10	63-19-6-2X	62-452-2	62-452-1	5-1-3141	63-16-3-1X	—	47-16-8-2X
-11	63-19-6-2X	62-452-3	62-453-4	6-1-2221	63-16-3-1X	—	47-16-8-2X
-12	Never Released for Production						
-13	63-19-6-2X	62-452-3	62-453-4	6-1-2221	63-16-1-1X	—	47-16-8-2X
-14	Never Released for Production						
-15	63-19-6-2X	—	—	—	—	—	—
-16	63-19-6-2X	62-452-9	62-453-8	6-1-2221	63-16-3-1X	—	47-16-8-2X
-17	63-19-6-2X	—	—	—	63-16-3-1X	—	47-16-8-2X
-18	63-19-6-2X	—	—	5-4-1661	63-16-1-1X	—	47-16-8-3X
-19	63-19-6-2X	—	—	5-4-1661	63-16-1-1X	—	—
-20	63-19-6-2X	62-452-9	—	—	63-16-9-1X	—	—
-21	63-19-6-2X	62-452-9	62-453-8	6-4-2361	63-16-1-1X	—	47-16-8-3X
-22	63-19-6-2X	—	—	—	63-16-1-1X	—	47-16-8-2X
-23	63-19-6-2X	—	—	—	63-16-3-1X	—	47-16-8-2X
-24	63-19-6-2X	62-452-3	62-453-5	6-1-2221	63-16-1-1X	—	47-16-8-2X
-25	63-19-6-2X	—	—	—	63-16-1-1X	—	47-16-8-2X
-26	63-19-6-2X	62-452-3	62-453-5	5-4-1661	63-16-1-1X	47-16-3-1X	—
-27	63-19-27-2X	62-452-3	62-453-3	6-1-2221	63-16-3-1X	—	—
-28	63-19-6-2X	—	—	4-1-3781	63-16-3-1X	47-16-3-1X	—
-29	63-19-6-2X	62-452-3	62-453-5	6-1-2221	63-16-3-1X	—	—
-30	63-19-6-2X	—	—	5-4-1661	63-16-1-1X	—	—
-31	63-19-38-1X	—	—	—	63-16-1-1X	—	—
-32	63-19-38-1X	63-452-3	—	5-4-7041-1	63-16-1-1X	—	—
-33	63-19-38-1X	63-452-3	—	6-4-3831-1	63-16-1-1X	—	—
-34	63-19-6-2X	62-452-3	62-453-4	4-1-3781	63-16-1-1X	—	—
-35	63-19-6-2X	62-452-3	62-453-4	4-1-3781	63-16-1-1X	47-16-3-1X	—
-36	63-19-6-2X	62-452-3	62-453-5	4-1-3781	63-16-1-1X	—	47-16-8-2X

For parts or service call us  
Pro Gear & Transmission, Inc.



**1 (877) 776-4600**

**(407) 872-1901**

**parts@eprogear.com**

**906 W. Gore St.**

**Orlando, FL 32805**

