



ES62-5 (ES67-5)

Parts Catalog

Bulletin No. T210-ES62-5

October 1993



For parts or service call us
Pro Gear & Transmission, Inc.



1 (877) 776-4600

(407) 872-1901

parts@eprogear.com

906 W. Gore St.

Orlando, FL 32805





MODEL ES62-5

CONTENTS, RATIO TABLE and IDENTIFICATION

T210-ES62-5

RATIO TABLE.....	1
GEARS and RELATED PARTS.....	2-6
DRIVE GEAR GROUP.....	2-3
MAINSHAFT GROUP.....	2-3
COUNTERSHAFT GROUP.....	4-5
REVERSE IDLER SHAFT GROUP.....	4-5
DRIVE GEAR TABLE.....	6
COMPANION FLANGES and END YOKES.....	7
DRIVE GEAR BEARING CAP GROUP.....	8-9
CASE GROUP and RELATED PARTS.....	8-9
REAR BEARING CAP GROUP and RELATED PARTS.....	10-11
CASE TABLE.....	12
DRIVE GEAR BEARING CAP TABLE.....	12
CLUTCH HOUSING DIMENSIONS.....	13
SHIFTER HOUSING ASSEMBLY.....	14-15
REMOTE CONTROL ASSEMBLY.....	16-18
SHIFT LEVER and DOME ASSEMBLY.....	19
CLUTCH RELEASE CODE TABLE.....	20-21
OVERHAUL KITS - MAJOR and MINOR.....	22-23
TABULATED BILLS OF MATERIAL.....	24-25

RATIO TABLE MODEL ES62-5

Speeds	Models		
	ES62-5A	ES62-5D	ES62-5E
1st	7.17	7.17	6.54
2nd	3.88	3.88	3.54
3rd	2.39	2.11	1.93
4th	1.45	1.29	1.17
5th	1.00	1.00	1.00
Rev.	7.17	7.17	6.54

IDENTIFICATION

The Name Plate (NP-96) affixed to the LEFT side of the Transmission is stamped with information:

SERIAL
 B/M No. MODEL

In requesting more information on these transmissions, furnish the B/M No. and the Serial Number.

Abbreviations used in this parts list include:

- N.S. — Not Shown
- N.S.S. — Not Sold Separately
- N.R. — Not Required

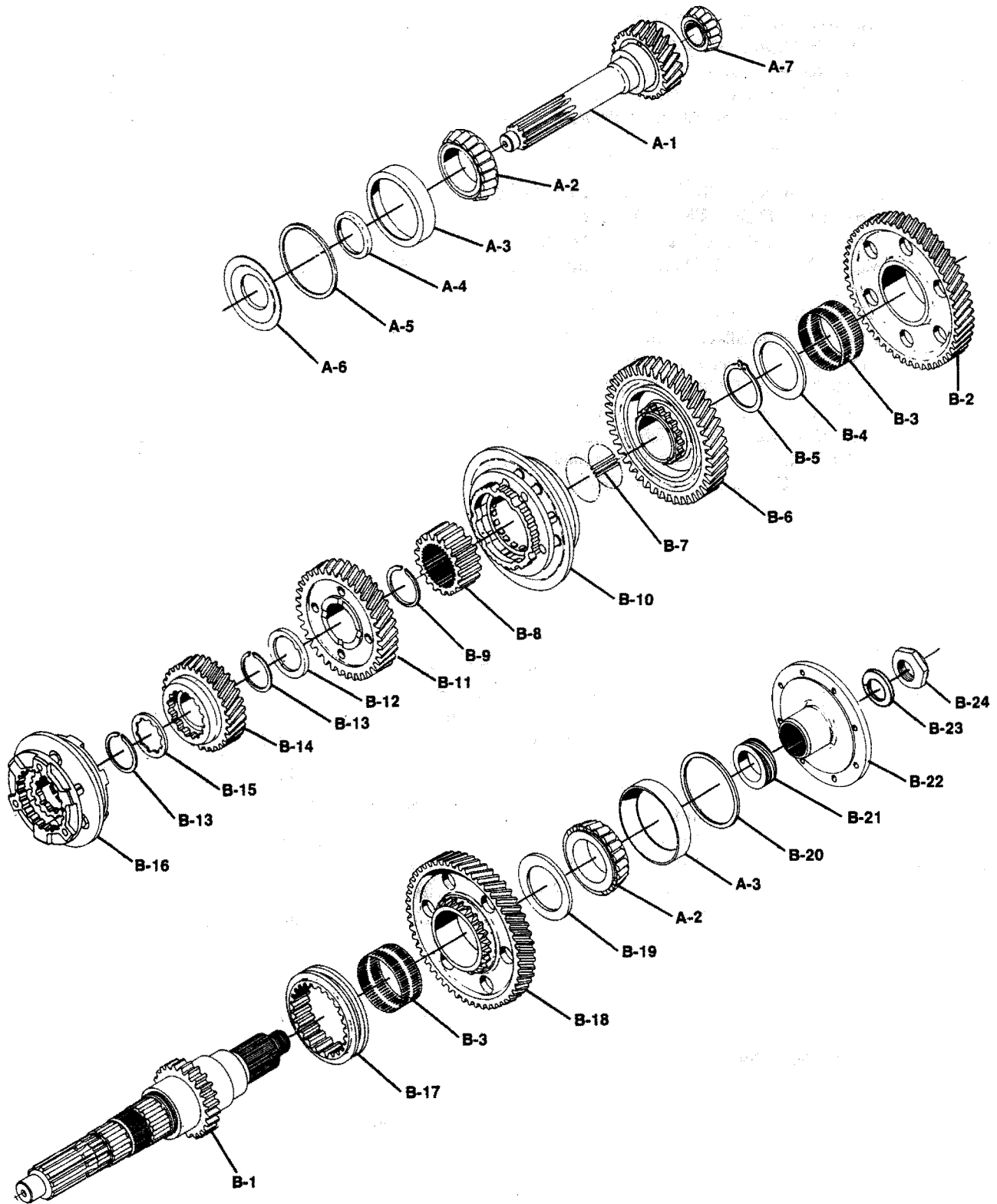



MODEL ES62-5 GEARS and RELATED PARTS

T210-ES62-5

Ref. No.	Part Number	Part Description	Qty.
DRIVE GEAR GROUP - INPUT			
A-1	See Tab Bills	Gear - Main Drive (See table page 6)	1
A-2	550930	Cone - Main Drive Gear Bearing	2
A-3	550929	Cup - Main Drive Gear Bearing	2
A-4	47-468-2 *	Baffle - Oil Ring Drive Gear	1
A-5	47-228-2-2 *	Spacer/Shim - Drive Gear Bearing	1
A-6	47-468-1 *	Baffle - Bearing Cap	1
A-7	550931	Cone - Drive Gear Pocket Bearing	1
MAINSHAFT GROUP - OUTPUT			
B-1	53-362-3	Mainshaft	1
or	53-362-8	Mainshaft (1 3/4" - 10 Spline industrial)	1
B-2	67-8-6	Gear - 1st Speed (42T)	1
B-3	550932	Bearing - 1st & Rev. Gear Needle Assy.	2
B-4	330866	Thrust Washer - 1st Speed Gear	1
B-5	27-381-5	Snap Ring - 1st Speed Thrust Washer	1
B-6	67-8-5	Gear - 2nd Speed (36T) ES62-5A, ES62-5D, ES62-5E	1
B-7	59-482-1-1X	Bearing Kit - 2nd Speed Needle (includes 61 Needles)	1
B-8	59-466-3	Gear - 2nd & 3rd Clutch (40T)	1
B-9	46-381-1	Snap Ring - 2nd & 3rd Clutch Gear	1
B-10	313823X	Synchronizer - 2nd & 3rd	1
B-11	67-8-3	Gear - 3rd Speed (35T) ES62-5A	1
or	67-8-4	Gear - 3rd Speed (33T) ES62-5D, ES62-5E	1
B-12	67-47-1	Thrust Washer - 3rd & 4th Speed	1
B-13	53-381-2	Snap Ring - 3rd & 4th Thrust Washer	2
B-14	67-8-1	Gear - 4th Speed (27T) ES62-5D, ES62-5E	1
or	67-8-2	Gear - 4th Speed (29T) ES62-5A	1
B-15	1016-W	Thrust Washer - 4th Speed	1
B-16	313822X	Synchronizer - 4th & 5th Speed	1
B-17	47-465-1	Clutch Collar - 1st & Rev.	1
B-18	53-8-1	Gear - Reverse (42T)	1
B-19	330867	Thrust Washer - Reverse Gear	1
B-20	313240-3X	Spacer & Shim Kit (to adjust Mainshaft end play)	1
B-21	See Tab Bills	Gear - Speedometer Drive	1
or	53-37-1	Spacer (used in place of Speedometer Drive Gear)	1
B-22	See Tab Bills	Companion Flange or End Yoke - U Joint (see table page 7)	1
B-23	53-205-1	Washer - 1 1/4" Flat	1
B-24	501200	Nut - Mainshaft (1 1/4"-18 Hex)	1

Use 313240-3X Baffle and Shim Kit when any of these parts are replaced, since the end play will be affected. Recommended end play is .003"-.008".

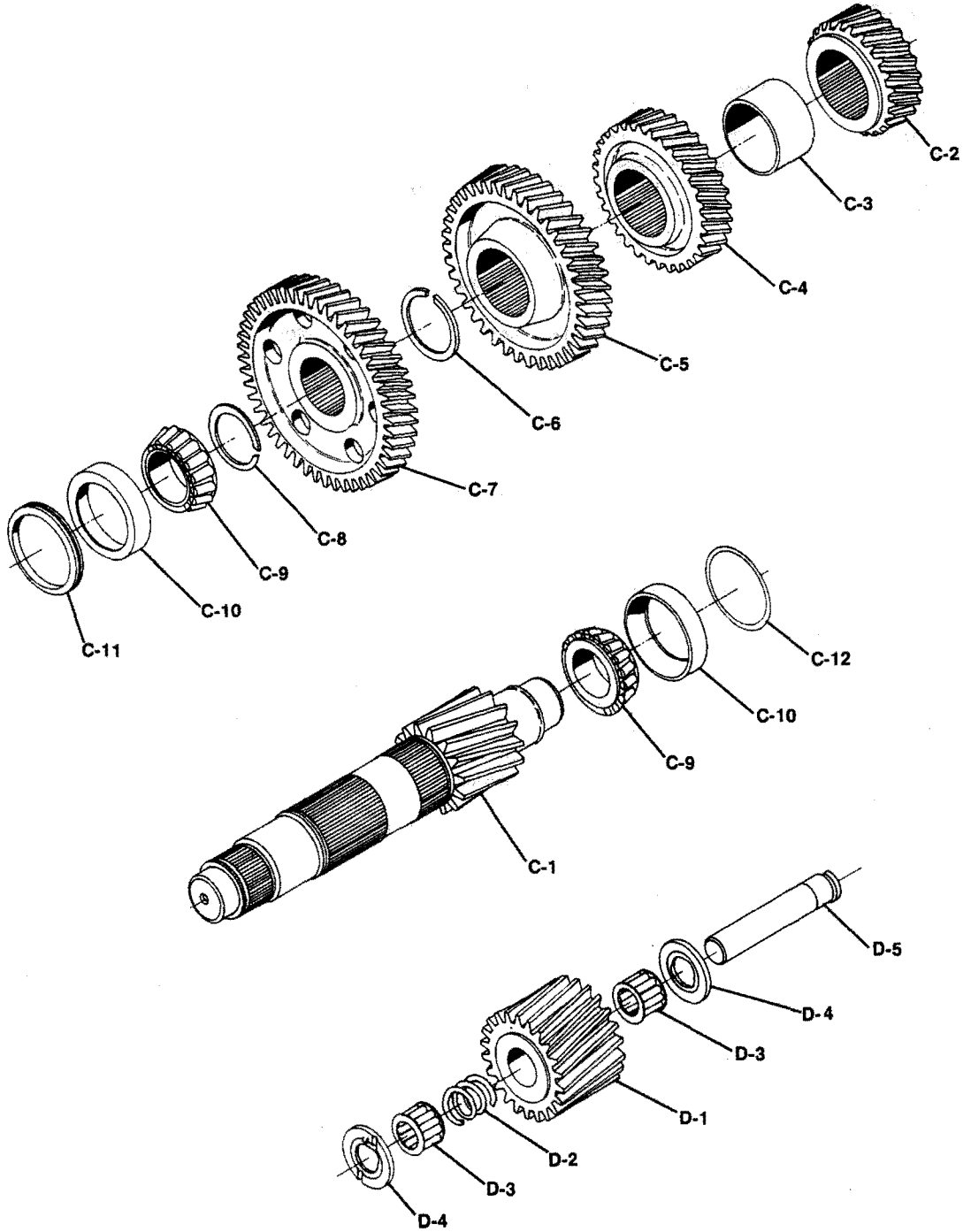



MODEL ES62-5 GEARS and RELATED PARTS

T210-ES62

Ref. No.	Part Number	Part Description	Qty.
C-1	53-30-3	Countershaft (12T)	1
or	59-30-1	Countershaft (12T) (for rear PTO drive)	2
C-2	67-196-5	Gear - 2nd Speed (19T) ES62-5A, ES62-5D, ES62-5D	1
C-3	59-37-1	Spacer - 2nd & 3rd Speed Gear	1
C-4	67-196-4	Gear - 3rd Speed (32T) ES62-5D, ES62-5E	1
	67-196-3	Gear - 3rd Speed (30T) ES62-5A	1
C-5	67-196-1	Gear - 4th Speed (43T) ES62-5D, ES62-5E	1
	67-196-2	Gear - 4th Speed (41T) ES62-5A	1
C-6	59-381-2	Snap Ring - 4th Speed Gear	1
C-7	67-1-1	Gear - Countershaft Drive (43T) ES62-5E	1
	67-1-2	Gear - Countershaft Drive (43T) ES62-5A, ES62-5D	1
C-8	59-381-1	Snap Ring - Countershaft Drive Gear	1
C-9	550927	Bearing - Cone Countershaft	2
C-10	550375	Bearing - Cup Countershaft	2
C-11	47-37-3	Spacer - Front Bearing Countershaft	1
C-12	313438X	Shim Kit - Countershaft Rear Bearing	1
REVERSE IDLER GROUP			
D-1	67-5-1	Gear - Reverse Idler (17T)	1
D-2	97-37-1	Spacer - Reverse Idler Bearing	1
D-3	550886	Bearing - Roller Reverse Idler	2
D-4	974-W	Thrust Washer	2
D-5	63-60-1	Shaft - Reverse Idler	1

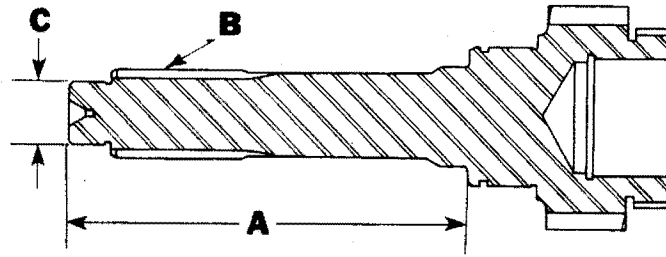

Teeth	A Length	B Spline Dia. Teeth	C - Pilot Size	Drive Gear Part No.
21	10.407"	1 3/4" - 10	1.180"	67-35-2-1X
23	8.844"	1 1/2" - 10	.9837"	67-35-1-1X

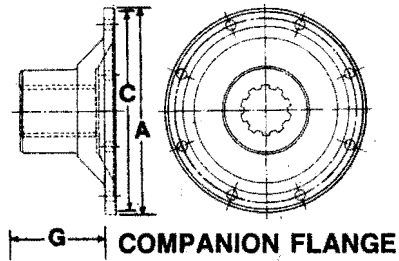

COMPANION FLANGE

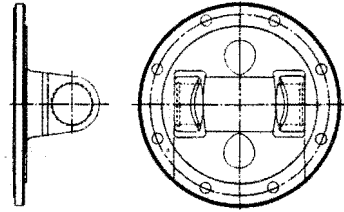

FLANGE YOKE

Companion Flanges

Joint Series	A Flange Diameter	Part No. Companion Flange	Part No. Companion Flange Assembly	G End of Hub to Flange Face Length	C Pilot Diameter F-Female M-Male	Brake Size
1480/1550	8"	53-106-1	—	5 ²¹ / ₃₂ "	M-6 ⁷ / ₁₆ "	9 x 3 or 12 x 4
1480/1550	Rectangular	53-106-2	—	2 ⁷ / ₈ "	F-3 ³ / ₄ "	—
1480/1550		4-1-6041	4-1-6051X			9 x 3
1610		5-1-6321	—			—
1710		6-1-5751	—			—

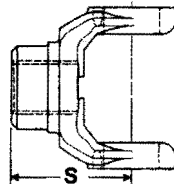

FULL ROUND

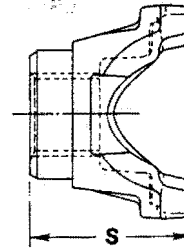

U-BOLT—BRG. STRAP—HALF ROUND

Series	Yoke Style	End Yoke Part Number	S End of Hub To Center Line Length	Momentary Joint Angle	Brake Size
1480	U-Bolt	3-4-8781	4 ¹¹ / ₆₄ "	22 ¹ / ₂ °	—
1480	Brg. Strap**	3-4-8931-2	3 ²⁹ / ₃₂ "	23 ¹ / ₂ °	—
1550	U-Bolt	4-4-4491	4 ¹ / ₆₄ "	21 ¹ / ₂ °	—
1550	Brg. Strap*	4-4-4491-1	4 ¹ / ₆₄ "	21 ¹ / ₂ °	—
1550	Brg. Strap**	4-4-4491-2	4 ¹ / ₆₄ "	21 ¹ / ₂ °	—
1550	Full Rnd.	4-4-4591			10 x 3
1550	U-Bolt	4-4-4601†	6 ²⁷ / ₆₄ "	22°	12 x 4
1550	U-Bolt	4-4-4611	4 ¹¹ / ₆₄ "	22 ¹ / ₂ °	—
1550	Brg. Strap*	4-4-4611-1	4 ¹¹ / ₆₄ "	22 ¹ / ₂ °	—
1550	Brg. Strap**	4-4-4611-2	4 ¹¹ / ₆₄ "	22 ¹ / ₂ °	—
1550	Half Rnd.	(A)4-4-6111-1X†	7 ¹ / ₃₂ "	22°	12 x 4
1610	Full Rnd.	5-4-6321	4"	19°	—
1610	Half Rnd.	5-4-6321-1	4"	19°	—
1610	Full Rnd.	5-4-6481	4 ¹¹ / ₆₄ "	22 ¹ / ₂ °	—
1610	Half Rnd.	5-4-6481-1	4 ¹¹ / ₆₄ "	22 ¹ / ₂ °	—
1610	Full Rnd.	5-4-6491†	6 ²¹ / ₃₂ "	22°	12 x 4
1610	Half Rnd.	(A)5-4-7611-1X†	7 ⁹ / ₁₆ "	22°	12 x 4
1710	Full Rnd.	6-4-7301	5 ¹ / ₄ "	33 ¹ / ₂ °	—
1710	Half Rnd.	6-4-7301-1	5 ¹ / ₄ "	33 ¹ / ₂ °	—

(A) Assembly Includes Brake Drum

† Flange Yokes

* With Tapped Holes

** With Thru Holes

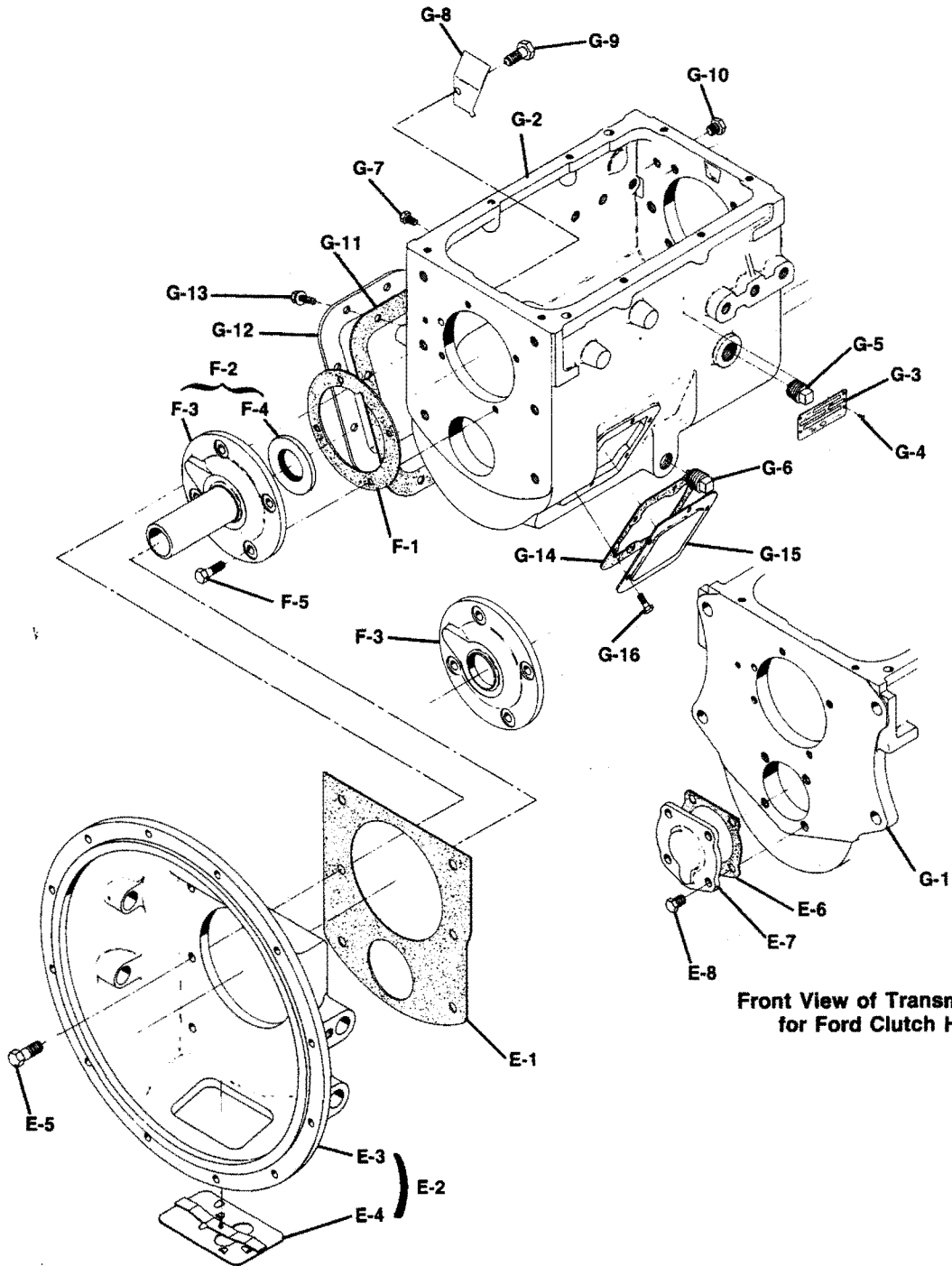

**Front View of Transmission Case
for Ford Clutch Housings**



MODEL ES62-5

CASE, BEARING CAP and RELATED PARTS

T210-ES62-5

Ref. No.	Part Number	Part Description	Qty.
CLUTCH HOUSING GROUP			
E-1	47-352-1	Gasket	1
E-2	See Tab Bills	Clutch Housing Assy. (includes E-3 thru E-4)(See table page 13)	1
E-3	N.S.S.	Clutch Housing	1
N.S.	128C-20	Bushing - (312256X & 312830X)	2
E-4	46-96-2-1X	Hand Hole Cover Assy.	1
E-5	See Page 13	Bolt - Hex head self-locking	6
	545001	Size 1/2"-13 x 1 1/4"	
	545001-1	Size 1/2"-13 x 1 3/8"	
	545001-5	Size 1/2"-13 x 1 1/8"	
	545001-6	Size 1/2"-13 x 1 5/8"	
COUNTERSHAFT FRONT BRG. CAP (Ford only - Case 59-15-5-2X)			
E-6	47-223-5	Gasket - Countershaft Front Bearing Cap	1
E-7	60-22-28	Cap - Countershaft Front Bearing	1
E-8	330801-1	Bolt - 7/16"-14 x 7/8" hex head self-locking	4
DRIVE GEAR BEARING CAP GROUP			
F-1	47-223-1	Gasket	1
F-2	See Tab Bills	Cap & Seal Assy. (see table page 12)	1
F-3	N.S.S.	Cap - Drive Gear Bearing	1
F-4	60-463-10-1X	Oil Seal - (includes installation sleeves)	1
F-5	545002-1	Bolt - 3/8"-16 x 7/8" hex head self-locking	4
CASE GROUP			
G-1	See Tab Bills	Case Assembly (see table page 12)(incl. G-2 thru G-10 plus 545089-1)	1
G-2	N.S.S.	Case	1
G-3	NP-96	Nameplate	1
N.S.	NP-196	Patent Plate	1
G-4	252-SP	Pin - Nameplate	4
G-5	500100	Filler Plug	1
G-6	62-39-3	Drain Plug - magnetic square head	1
or	62-39-4	Drain Plug - magnetic recessed head	1
G-7	545002-10	Bolt - 3/8"-16 x 1/2" hex head (left hand side)	2
G-8	330923	Oil Trough	1
G-9	545009	Bolt - 5/16"-18 x 5/8" flanged head self-locking	1
G-10	307-D	Plug - 1/2"-13 x 1/2" hex head	2
and	266-D	Plug - 5/8"-11 x 7/16" hex head	2
N.S.	545089-1	Plug - 9/16"-12 x 3/4" hex head, brake anchor bar	6
G-11	97-324-2	Gasket - 8 bolt P.T.O. aperture cover	1
G-12	73-267-1	Cover - 8 bolt P.T.O. aperture	1
G-13	545012	Bolt - 7/16"-14 x 3/4" flanged hex head self-locking	8
G-14	97-324-1	Gasket - 6 bolt P.T.O. aperture cover	1
G-15	50-267-2	Cover - 6 bolt P.T.O. aperture	1
G-16	330800	Bolt - 3/8"-16 x 3/4" hex head self-locking	6

N.S.S. -- Not Sold Separately

N.S. -- Not Shown

H-1
 See Chart

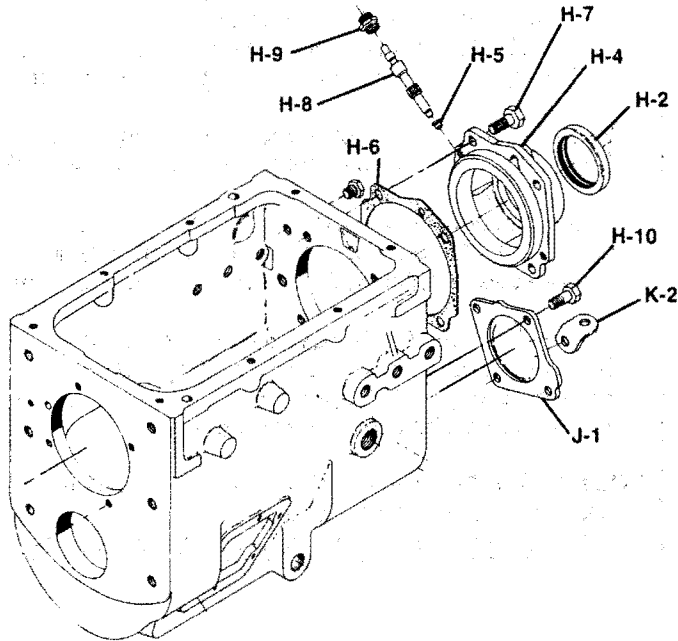

REAR BEARING CAP CHART

Service Part Number	Oil Seal H-4	Sub-assys. include			
		Casting Number	Speedo Bushing H-5	Gasket H-6	Brake Type
53-19-24-2X	60-463-8	C53-19-24	30-475-1	47-223-3	-
53-19-26-2X	60-463-8	C53-19-27	-	53-223-1	12" x 4"



MODEL ES62-5 REAR BEARING CAP GROUP and RELATED PARTS

T210-ES62-5

Ref. No.	Part Number	Part Description	Qty.
MAINSHAFT REAR BEARING CAP GROUP			
H-1	See Tab Bills	Cap Assembly—mainshaft rear bearing (See chart below)	1
H-2	60-463-8	Oil Seal—mainshaft rear bearing cap	1
	63-463-1	Oil Seal (Ford only)	1
H-4	N.S.S.	Cap—mainshaft rear bearing	1
H-5	See chart below	Bushing—speedometer	1
H-6	47-223-3	Gasket—mainshaft rear bearing cap	1
	53-223-1	Gasket—mainshaft rear bearing cap (IHC Bendix brake mounting)	1
	60-223-7	Gasket—mainshaft rear bearing cap (Ford only)	1
H-7	545001	Bolt— $\frac{1}{2}$ "-13 x $1\frac{1}{4}$ " hex head self locking	4
and	545008	Bolt— $\frac{5}{8}$ "-11 x $1\frac{1}{4}$ " hex head self locking (for brake cap)	2
H-8	See Tab Bills	Gear—speedometer driven	1
or	55-334-1	Plug—speedometer hole (use w/o driven gear)	1
N.S.	545021	Plug—speedometer outlet (electronic bearing caps)	1
H-9	55-454-1	Sleeve—Length $1\frac{1}{4}$ " speedometer driven gear	1
	44-473-1	Sleeve—Length 5" speedometer driven gear	1
	97-454-2-1X	Sleeve—Length $1\frac{1}{4}$ " speedometer driven gear (with seal)	1
H-10	545002-1	Bolt—countershaft rear bearing cap	4
COUNTERSHAFT REAR BEARING CAP GROUP			
J-1	59-22-1	Cap—countershaft rear bearing	1
K-2	330564-3	Lift Hook—countershaft rear bearing cap	1

N.S. - Not Shown

MODEL ES62-5



0-ES62-5

CASE and FRONT BEARING CAP TABLE w/Clutch Applications

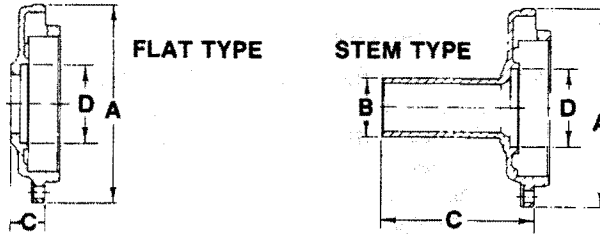

FRONT BEARING CAP CHART

A Outside Diameter	B Stem Diameter	C Length	D Oil Seal Bore Diameter	FRONT BEARING CAP	
				Casting Number	Assembly Includes Oil Seal F-2
PULL TYPE RELEASE					
6 ³ / ₈ "	—	1 ¹¹ / ₃₂ "	2 ¹ / ₂ "	C47-19-2-1	53-19-11-1X
PUSH TYPE RELEASE					
6 ³ / ₈ "	1.940"	6 ⁷ / ₃₂ "	2 ¹ / ₂ "	C47-19-83	47-19-74-1X
6 ³ / ₈ "	1.872"	5 ¹¹ / ₃₂ "	2 ¹ / ₂ "	C47-19-70	47-19-78-1X
6 ³ / ₈ "	1.872"	5 ¹⁹ / ₃₂ "	2 ¹ / ₂ "	C47-19-70	47-19-82-1X
7 ⁷ / ₃₂ "	1.940"	6 ⁷ / ₃₂ "	2 ¹ / ₂ "	C47-19-76	47-19-73-1X
6 ³ / ₈ "	1.872"	5 ²⁵ / ₃₂ "	2 ¹ / ₂ "	C47-19-70	47-19-77-1X
7 ¹ / ₈ "	1.808"	5 ⁵ / ₃₂ "	2 ¹ / ₂ "	C47-19-81	47-19-79-1X
6 ³ / ₈ "	2.246"	5 ¹³ / ₁₆ "	2 ¹ / ₂ "	C47-19-71	47-19-80-1X

CASE TABLE

Case Assembly G-1	Case (N.S.S.) Casting No.	Bolt ■G-9 Oil Trough G-8	(4 Pins) G-4 Name Plate G-3	OIL PLUG		CASE PLUG			Brake Anchor Bar Bolt or Plug N.S.
				Filler G-5	Drain G-6	Side G-7	Rear G-10	Rear G-10	
5-1-2X	C59-15-2	330923	NP-96	500100	62-39-4	—	—	—	545089-1
5-5-2X	C59-15-2	330923	NP-96	500100	62-39-4	—	—	—	545089-1
5-7-2X	C59-15-4-1	330923	NP-96	500100	62-39-3	545002-7	307D	266D	—
5-9-2X	C59-15-4	330923	NP-96	500100	62-39-3	—	307D	266D	545089-1
5-3-2X	C59-15-4	330923	NP-96	500100	62-39-3	—	307D	266D	545089-1
5-10-2X	C59-15-4	330923	NP-96	500100	62-39-3	545002-10	307D	—	545089-1

case is no longer available. Service with 59-15-9-2X.
 case assembly uses (3) 307D rear plug.
 — Not Shown

SAE		
Size No.	A Pilot Dia.	B O.D.
1	20 ¹ / ₈ "	21 ³ / ₄ "
2	17 ⁵ / ₈ "	19 ¹ / ₄ "
3	16 ¹ / ₈ "	17 ³ / ₄ "

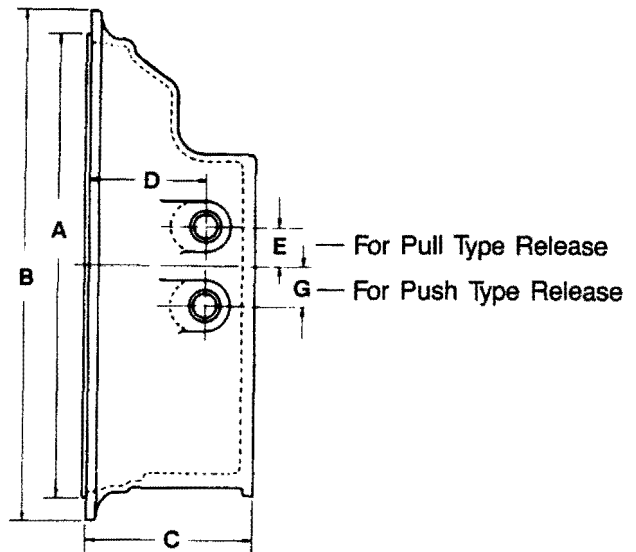

CLUTCH HOUSING				C Length	RELEASE SHAFT HOLE				Use With Bolt E-5
Service Assembly No. E-2	Bushing Number	Casting Part Number	S A E		Dia.	C/L Front Face	D E Above C/L	G Below C/L	
46-518-13-1X*	—	C46-518-14	2	4 ³ / ₄ "	—	—	—	—	545001-5
46-518-21-1X	—	C102C-477	3	5 ¹ / ₁₆ "	1"	3" 2 ¹⁷ / ₃₂ "	1 ¹ / ₂ " —	— 2 ⁵ / ₈ "	545001-5
46-518-22-1X	—	C102C-530-1	2	5 ¹ / ₁₆ "	1"	3" 2 ¹⁷ / ₃₂ "	1 ¹ / ₂ " —	— 2 ⁵ / ₈ "	545001-5
46-518-23	—	C46-518-18-1	2	5 ⁵ / ₈ "	1"	2 ³ / ₄ " 2 ³ / ₄ "	3" —	— 3"	545001
47-518-4-1X	—	Special	2	6 ⁵ / ₈ "	1"	3 ³ / ₄ "	1 ¹ / ₂ "	—	545001-1
47-518-5	—	C47-518-6	2	6 ¹ / ₂ "	1 ¹ / ₈ "	2 ¹⁹ / ₃₂ "	—	2 ¹ / ₂ "	545001-6
47-518-10-1X	—	C47-518-11	2	4 ³ / ₄ "	—	—	—	—	545001-5
59-518-1-1X	128C-20	Special	2	6 ⁵ / ₈ "	1"	3 ³ / ₄ "	1 ¹ / ₂ "	—	545001-1
312256X*	128C-20	C46-518-16	2	6"	1"	3 ⁵ / ₈ "	—	2 ¹ / ₂ "	545001-5
312830X	128C-20	C102C-530-1	2	5 ¹ / ₁₆ "	1"	2 ¹⁷ / ₃₂ "	—	2 ⁵ / ₈ "	545001-5

*Nodal Mount

MODEL ES62-5 SHIFTER HOUSE ASSEMBLY

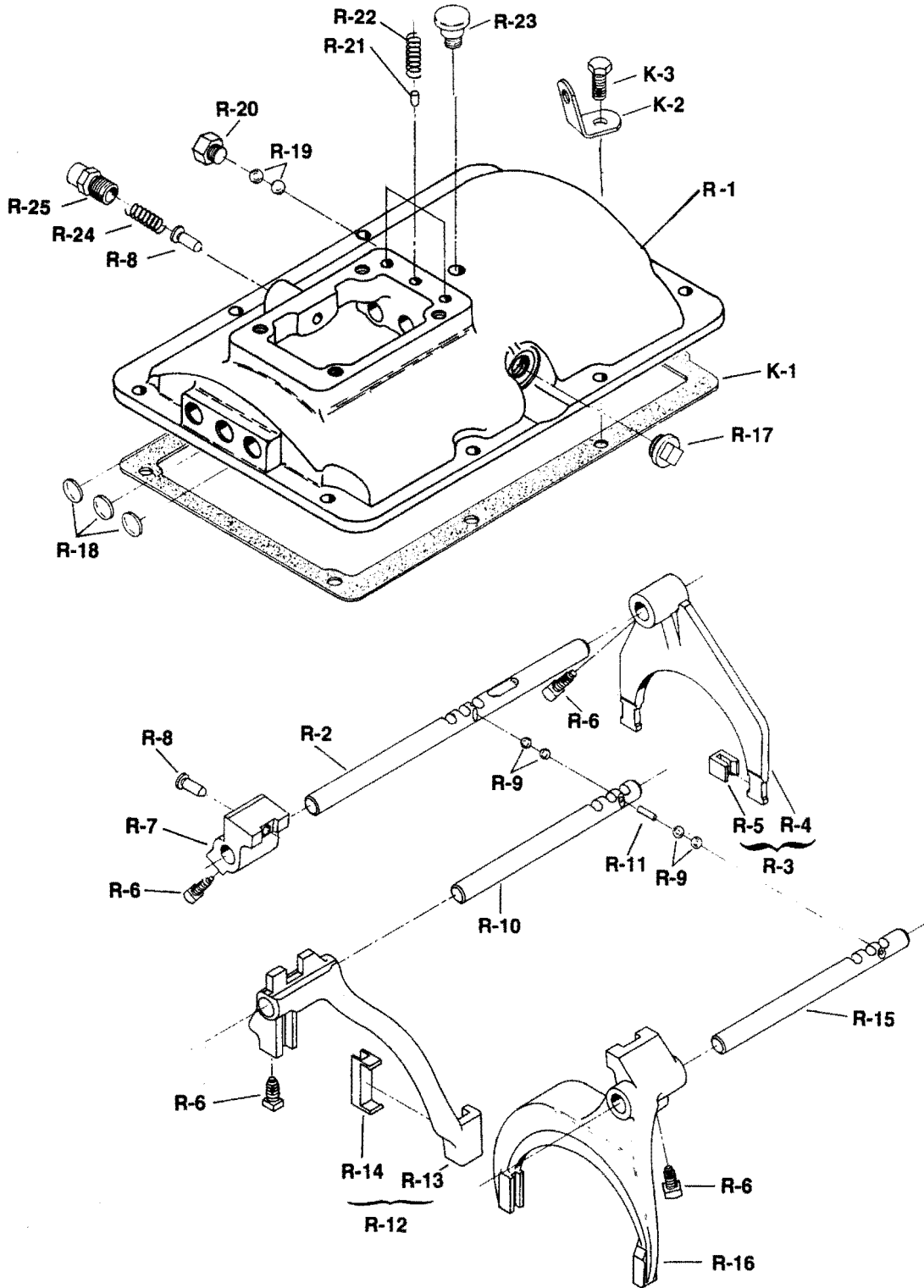



MODEL ES62-5 SHIFTER HOUSING ASSEMBLY

T210-ES62-5

Ref. No.	Part Number	Part Description	Qty.
	See Tab Bills	SHIFTER HOUSING ASSEMBLY	1
R-1	47-16-1-1	Shifter Housing	1
R-2	47-67-1	Rod - 1st and Reverse Shift	1
R-3	59-66-1-1X	Fork & Clip Assy. - 1st and Reverse Shift	1
R-4	N.S.S.	Fork - 1st and Reverse Shift	1
R-5	46-486-2	Clip - Shift Fork	2
R-6	330639	Bolt - 3/8"-24 x 3/4" square head self-locking	4
R-7	53-354-1	Bracket - 1st and Reverse Shift Rod	1
R-8	62-438-2	Pin - 1st and Reverse shift finger plunger	2
R-9	50-80-1	Ball - Shift rod poppet and interlock	4
R-10	46-67-5	Rod - 2nd and 3rd shift	1
R-11	277-SP	Pin - Interlock	1
R-12	53-66-3-1X	Fork - 2nd and 3rd Shift	1
R-13	N.S.S.	Shift Fork	1
R-14	53-486-1	Clip - Shift Fork	2
R-15	47-67-2	Rod - 4th and 5th shift	1
R-16	53-66-1	Fork - 4th and 5th shift	1
R-17	545021	Plug - interlock	1
R-18	330894	Expansion plug - 3/4" (aluminum)	3
R-19	50-80-4	Ball - backup switch	2
R-20	330366	Plug - backup switch hole	1
R-21	50-80-1	Ball - Shift Rod Poppet	3
R-22	47-72-1	Spring - Shift rod poppet	3
R-23	312268	Breather Assembly	1
R-24	See Chart	Spring - shift finger plunger 1st and Reverse	1
R-25	38P-1	Retainer - shift finger plunger 1st and Reverse	1
		PARTS LISTED BELOW ARE INCLUDED IN ASSEMBLY	
K-1	47-155-1	Gasket - shifter housing	1
K-2	330564-1	Lift Hook - shifter housing	2
K-3	545002	Bolt - 3/8"-16 x 1" hex head self-locking	6
and	545002-4	Bolt - 3/8"-16 x 1 1/8" hex head self-locking (for lift hook)	2
N.S.	313262X *	Neutral Start Switch Actuator Kit (see tab bills)	1

1st and Reverse Spring Chart (Ref. No. R-24)

Shifter Housing Assembly	Shifter Finger Plunger Spring	Spring Load	Free Length
47-16-1-8X	62-72-8	60#	2 1/64"
47-16-1-11X	30-72-6	28#	2 1/8"
47-16-1-13X	30-72-6	28#	2 1/8"
47-16-1-12X	82-72-3	15#	2 3/8"
47-16-1-16X	62-72-8	60#	2 1/64"
47-16-1-17X	62-72-8	60#	2 1/64"
47-16-1-18X	62-72-8	60#	2 1/64"

* Does not include Start Switch

N.S. - Not Shown N.S.S. - Not Sold Separately

MODEL ES62-5 REMOTE CONTROL ASSEMBLY (High Rod Type)

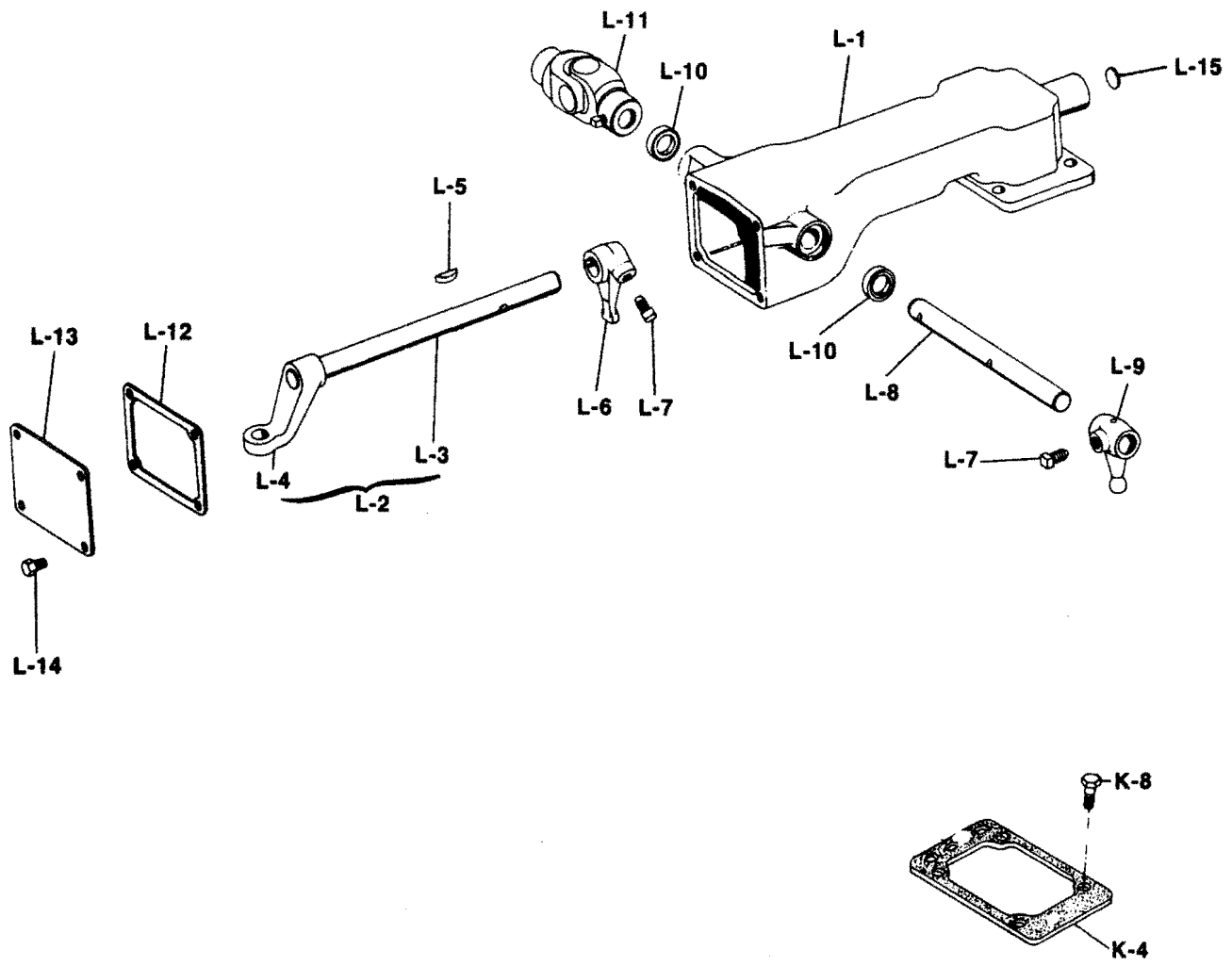



MODEL ES62-5

REMOTE CONTROL ASSEMBLY

High Rod Type

T210-ES62-5

Ref. No.	Part Number	Part Name	Remote Control Assembly	47-16-8-2X	47-16-8-3X	47-16-9-2X	47-16-12-2X
	See Tab Bills	COVER & JOINT ASSEMBLY—REMOTE CONTROL		1	1	1	1
	47-16-8-1X	Cover Assembly (Casting No. 62-16-78)		1	1		
	47-16-9-1X	Cover Assembly (Casting No. 62-16-78-1)				1	
	47-16-12-1X	Cover Assembly (Casting No. 62-16-128)					1
L-1	N.S.S.	Remote Control Cover		1	1	1	1
N.S.	82-24-3	Bushing—remote control cover		4	4	4	4
L-2	310647X	Shift Finger Rod & Bracket Assembly		1	1		
	310879X	Shift Finger Rod & Bracket Assembly				1	
	312003X	Shift Finger Rod & Bracket Assembly					1
L-3	N.S.S.	Rod—shift finger		1	1	1	1
L-4	N.S.S.	Bracket—shift finger rod		1	1	1	1
L-5	500007-19	Woodruff Key—No. 11 (part of assembly)		1	1	1	1
L-6	62-6-24	Finger—inner shift		1	1	1	1
L-7	545011	Bolt— $\frac{7}{16}$ "-20 x $\frac{7}{8}$ " hex head self-locking		2	2	2	2
L-8	82-65-5	Rod—remote control shift		1	1	1	1
L-9	82-6-7	Finger—outer shift		1	1	1	1
L-10	28P-19	Seal—remote control shift rod		2	2	2	2
L-11	10380-SF	U-Joint Assembly—control		1	1	1	1
L-12	82-118-1	Gasket—aperture cover		1	1	1	1
L-13	82-96-1	Aperture Cover		1	1	1	1
L-14	545005-1	Bolt— $\frac{5}{16}$ "-18 x $\frac{5}{8}$ " hex head self-locking		4	4	4	4
L-15	500166-16	Expansion Plug— $1\frac{1}{16}$ "		1	1	1	1
N.S.	311903X	Boot Kit—remote control			1		
N.S.	82-483-1	Boot			1		
N.S.	82-483-2	Boot—cup type			1		
N.S.	LW-3-9	Lockwire			3		
		PARTS LISTED BELOW ARE NOT INCLUDED IN ASSEMBLY					
K-4	62-155-13	Gasket—shifter housing to control cover		1	1	1	1
K-8	545028-4	Bolt— $\frac{7}{16}$ "-14 x $1\frac{1}{4}$ " hex head self-locking		4	4	4	4

N.S. — Not Shown
 N.S.S. — Not Sold Separately

MODEL ES62-5
REMOTE CONTROL ASSEMBLY
Two-Lever Type - Cable or Rod Control

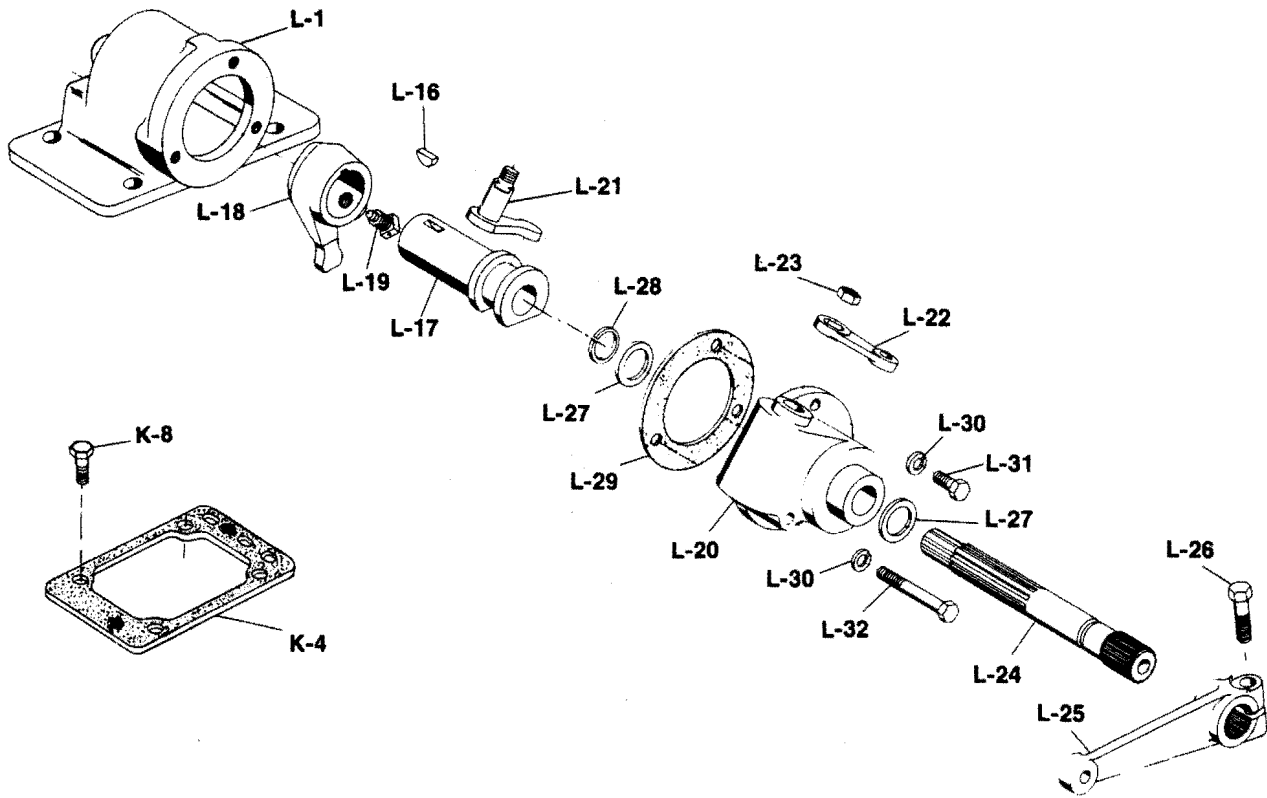

Ref. No.	Part Number	Part Description	Qty.
	311528-7X	REMOTE CONTROL COVER ASSEMBLY (See Tab Bills)	1
L-1	47-16-13	Remote Control Cover	1
L-16	500007-17	Woodruff Key #91	1
L-17	62-65-26	Shaft—inner shift finger	1
L-18	62-6-30	Shift Finger—inner	1
L-19	545063	Bolt— $\frac{7}{16}$ "-20 x $1\frac{3}{16}$ " hex head self-locking	1
L-20	62-16-92	End Cover—remote control	1
L-21	310926X	Cam and Stud Assembly—selection lever	1
L-22	62-6-59	Lever—upper selection	1
L-23	500381-4	Nut— $\frac{7}{16}$ "-20	1
L-24	62-65-27	Rod—outer shift lever	1
L-25	47-6-1	Lever—outer shift	1
L-26	545002-7	Bolt— $\frac{3}{8}$ "-16 x $1\frac{1}{2}$ "	1
L-27	258-W	Washer—shift lever rod	2
L-28	62-381-13	Snap Ring	1
L-29	62-155-11	Gasket—end cover	1
L-30	500357-10	Lock Washer $\frac{5}{16}$ "	1
L-31	545005-2	Bolt— $\frac{5}{16}$ "-18 x $\frac{7}{8}$ "	2
L-32	500397-22	Bolt— $\frac{5}{16}$ "-18 x $2\frac{1}{2}$ "	1
		PARTS LISTED BELOW ARE NOT INCLUDED IN ASSEMBLY	
K-4	62-155-13	Gasket—shifter housing to control cover	1
K-8	545028-4	Bolt— $\frac{7}{16}$ "-14 x $1\frac{1}{4}$ " hex head self-locking	4

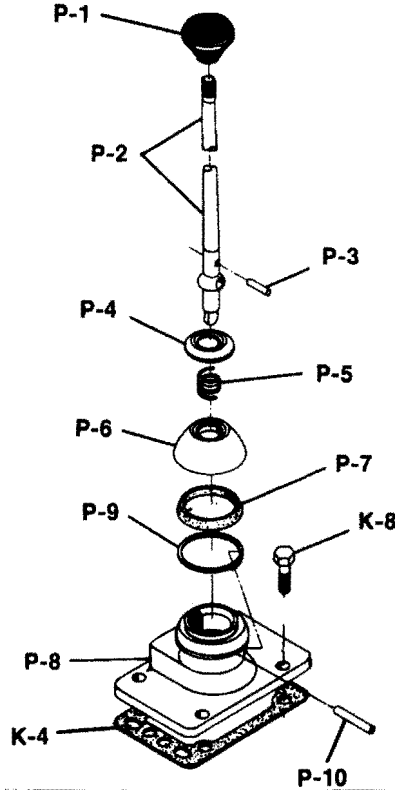

Ref. No.	Part Number	Part Description	47-16-5-38X	47-16-5-22X	47-16-5-43X	47-16-3-1X	47-16-3-25X	47-16-5-21X
	See Tab Bills	Lever and Dome Assembly—shift	1	1	1	1	1	1
P-1	39Q-27	Handle—shift lever	1			1	1	
P-2	25Q-1121	Shift Lever 26 1/4" Straight				1		
	25Q-1122	Shift Lever 29 1/4" Straight					1	
	25Q-1621	Shift Lever 30" Straight	1					1
	25Q-1537	Shift Lever		1				
	25Q-2464	Shift Lever—lower end (3.5")			1			
N.S.	55Q-5	Grommet—shift lever (boot)	1	1				1
	47-16-3X	Dome Assembly—2 5/8" overall height				1	1	
	47-16-5X	Dome Assembly—3 5/8" overall height	1	1	1			1
P-3	286-SP	Pin—shift lever collar	1	1	1	1	1	1
P-4	55Q-7	Collar—compression	1	1	1	1	1	1
P-5	56Q-25	Spring—compression	1	1	1	1	1	1
P-6	54Q-13	Cup—compression	1	1	1	1	1	1
P-7	69Q-6	Washer—friction	1	1	1	1	1	1
P-8	47-16-3	Dome—shift lever				1	1	
	47-16-5	Dome—shift lever	1	1	1			1
P-9	62-381-7	Snap Ring—rock shaft	1	1	1	1	1	1
P-10	53Q-15	Shaft—shift lever rock	1	1	1	1	1	1
		PARTS LISTED BELOW ARE NOT INCLUDED IN ASSEMBLY						
K-4	62-155-13	Gasket—dome to shifter housing	1	1	1	1	1	1
K-8	545002	Screw—7/16"-14 x 1 1/8" hex head self-locking	4	4	4	4	4	4
N.S. — Not Shown								

T210-ES62-5

MODEL ES62-5
CLUTCH RELEASE CODE TABLE



Rel.Code See Tab Bill	CR-7 Yoke ★	Shaft		Adjustable Arm	D Dim. (In.)	Rel.Code See Tab Bill	CR-7 Yoke ★	Shaft		Adjustable Arm	D Dim. (In.)
		CR-1 Short	CR-2 Long					CR-1 Short	CR-2 Long		
1	105C-64	106C-1142	106C-1047	310233X	11.969	60	105C-137	106C-1185	106C-617	310233X	12.969
2	105C-64	106C-1185	106C-438	—	16.500	61	105C-137	106C-1185	106C-839	310233X	13.969
3	105C-64	106C-1185	106C-939	310233X	12.500	62	105C-137	106C-1185	106C-939	310233X	12.500
4	105C-64	106C-1185	106C-1046	310233X	11.468	63	105C-137	106C-1185	106C-939	310473X	12.500
5	105C-64	106C-1185	106C-1047	310233X	11.969	64	105C-137	106C-1185	106C-953	310473X	12.250
6	105C-64	106C-1185	106C-1047	47-526-1-1X	11.969	65	105C-137	106C-1185	106C-1046	310233X	11.468
7	105C-64	106C-1544	106C-839	310233X	13.969	66	105C-137	106C-1185	106C-1046	310473X	11.468
8	105C-68	106C-1142	106C-438	—	16.125	67	105C-137	106C-1185	106C-1047	310233X	11.969
9	105C-68	106C-1142	106C-617	—	12.594	68	105C-137	106C-1185	106C-1083	310233X	10.469
10	105C-68	106C-1142	106C-617	310233X	12.594	69	105C-137	106C-1185	106C-1094	—	10.969
11	105C-68	106C-1142	106C-839	310233X	13.594	70	105C-137	106C-1185	106C-1094	310233X	10.969
12	105C-68	106C-1142	106C-939	310233X	12.125	71	105C-137	106C-1185	106C-1123	—	15.468
13	105C-68	106C-1142	106C-1046	310233X	11.093	72	105C-137	106C-1185	106C-1123	310233X	15.468
14	105C-68	106C-1142	106C-1047	310233X	11.594	73	105C-137	106C-1185	106C-1367	—	12.812
15	105C-68	106C-1278	106C-438	—	16.125	74	105C-137	106C-1185	106C-1367	310233X	12.812
15A	105C-68	106C-1278	106C-939	310473X	12.125	75	105C-137	106C-1185	106C-1375	310873X	9.281
15B	105C-68	106C-1278	106C-939	310233X	12.125	76	105C-137	106C-1185	106C-1515	—	13.875
16	105C-117	106C-1071	106C-939	310233X	12.750	77	105C-137	106C-1185	106C-1529	—	10.812
17	105C-117	106C-1071	106C-1094	310233X	11.219	78	105C-137	106C-1185	330610-5	—	11.969
18	105C-117	106C-1142	106C-939	310233X	12.750	78A	105C-137	106C-1185	46-510-9	—	9.625
19	105C-117	106C-1185	106C-438	—	16.750	79	105C-137	106C-1216	106C-617	310233X	12.969
20	105C-117	106C-1185	106C-617	310233X	13.219	80	105C-137	106C-1278	106C-438	—	16.500
21	105C-117	106C-1185	106C-839	47-526-1-1X	14.219	81	105C-137	106C-1278	106C-588	—	9.500
22	105C-117	106C-1185	106C-939	310233X	12.750	82	105C-137	106C-1278	106C-588	310233X	9.500
23	105C-117	106C-1185	106C-953	310873X	12.500	83	105C-137	106C-1278	106C-617	310233X	12.969
24	105C-117	106C-1185	106C-960	310233X	11.469	84	105C-137	106C-1278	106C-939	310233X	12.500
25	105C-117	106C-1185	106C-1046	310233X	11.718	84A	105C-137	106C-1278	106C-939	310473X	12.500
26	105C-117	106C-1185	106C-1047	310233X	12.219	85	105C-137	106C-1278	106C-939	310873X	12.500
27	105C-117	106C-1185	106C-1083	—	10.719	86	105C-137	106C-1278	106C-960	310233X	11.219
28	105C-117	106C-1185	106C-1083	310233X	10.719	87	105C-137	106C-1278	106C-1046	—	11.468
29	105C-117	106C-1185	106C-1083	310473X	10.719	88	105C-137	106C-1278	106C-1046	310233X	11.468
30	105C-117	106C-1185	106C-1094	310233X	11.219	89	105C-137	106C-1278	106C-1047	—	11.969
31	105C-117	106C-1185	106C-1094	310873X	11.219	90	105C-137	106C-1278	106C-1047	310233X	11.969
32	105C-117	106C-1185	106C-1169	310233X	11.875	91	105C-137	106C-1278	106C-1083	310233X	10.469
33	105C-117	106C-1185	106C-1315	—	10.375	91A	105C-137	106C-1278	106C-1083	310473X	10.469
34	105C-117	106C-1185	106C-1315	310233X	10.375	92	105C-137	106C-1278	106C-1094	310233X	10.969
35	105C-117	106C-1185	106C-1315	47-526-1-1X	10.375	92A	105C-137	106C-1278	106C-1315	310233X	10.125
35A	105C-117	106C-1185	106C-1375	310873X	9.531	93	105C-137	106C-1278	106C-1375	310233X	9.281
36	105C-117	106C-1185	106C-1417	310233X	10.000	94	105C-137	106C-1278	106C-1422	310233X	10.000
37	105C-117	106C-1185	106C-1417	310873X	10.000	95	105C-137	106C-1278	106C-1529	—	10.812
38	105C-117	106C-1185	106C-1490	310233X	18.750	96	105C-137	106C-1360	106C-1083	—	10.469
39	105C-117	106C-1278	106C-939	310233X	12.750	96A	105C-137	106C-1360	106C-1417	310233X	9.750
40	105C-117	106C-1278	106C-960	310873X	11.469	97	105C-137	106C-1360	106C-1422	310233X	10.000
41	105C-117	106C-1278	106C-1047	310233X	12.219	98	105C-137	106C-1375	106C-438	310233X	16.500
42	105C-117	106C-1278	106C-1094	310233X	11.219	99	105C-137	106C-1498	106C-438	—	16.500
43	105C-117	106C-1278	106C-1315	310233X	10.375	100	105C-137	106C-1498	106C-617	310233X	12.969
44	105C-117	106C-1278	106C-1367	310233X	13.062	101	105C-137	106C-1498	106C-617	310473X	12.969
45	105C-117	106C-1360	106C-1083	310233X	10.719	102	105C-137	106C-1498	106C-939	310233X	12.500
46	105C-117	106C-1360	106C-1315	310233X	10.375	103	105C-137	106C-1498	106C-939	310473X	12.500
46A	105C-117	106C-1360	330610-10	—	12.250	104	105C-137	106C-1498	106C-953	310233X	12.250
47	105C-117	Thru Shaft	106C-1550	—	—	105	105C-137	106C-1498	106C-959	310233X	14.468
48	105C-117	Thru Shaft	106C-1558	—	—	106	105C-137	106C-1498	106C-1046	310233X	11.468
49	105C-124	106C-1185	106C-438	—	14.313	107	105C-137	106C-1498	106C-1047	—	11.969
50	105C-124	Thru Shaft	106C-1566	310233X	—	108	105C-137	106C-1498	106C-1047	310233X	11.969
51	105C-124	Thru Shaft	106C-1566	310473X	—	109	105C-137	106C-1498	106C-1083	310233X	10.469
52	105C-124	Thru Shaft	106C-1566	310873X	—	110	105C-137	106C-1498	106C-1094	—	10.969
52A	105C-124	Thru Shaft	49-510-1	310233X	—	111	105C-137	106C-1498	330610-11	310233X	13.250
53	105C-132	106C-1185	106C-1047	310233X	9.782	112	105C-137	330601-1	106C-939	310233X	12.500
54	105C-132	106C-1185	106C-1083	310233X	8.282	112A	85-509-3	106C-1278	106C-939	310233X	12.750
55	105C-132	106C-1185	106C-1417	310873X	7.563	113	85-509-3	106C-1360	106C-1417	310233X	10.000
56	105C-132	106C-1185	46-510-9	—	7.438	114	85-509-3	Thru Shaft	106C-1578	310233X	—
57	105C-132	106C-1278	46-510-9	—	7.438	114A	85-509-3	Thru Shaft	106C-1578	310473X	—
58	105C-137	106C-1141	106C-1169	310233X	11.625	115	85-509-3	Thru Shaft	106C-1578	310873X	—
59	105C-137	106C-1185	106C-438	—	16.500	116	312916	Thru Shaft	97-510-2	—	—

■ Use 7743X Clutch Release Bearing and (2) 2306-12 Springs.

MODEL ES62-5 CLUTCH RELEASE CODE TABLE

T210-ES62-5

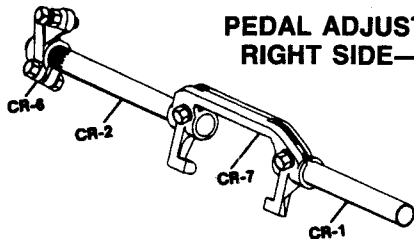

**PEDAL ADJUSTING ARM
RIGHT SIDE—310473X**

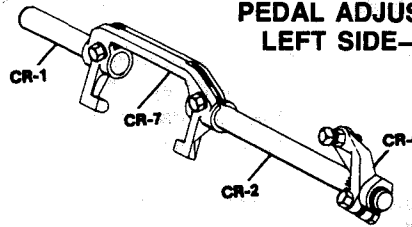

**PEDAL ADJUSTING ARM
LEFT SIDE—310233X**

CR-1 SHORT SHAFT

Part No.	Length
106C-1071	4.062"
106C-1141	5.125"
106C-1142	6.125"
106C-1185	5.750"
106C-1216	4.750"
106C-1278	4.812"
106C-1360	5.312"
106C-1375	6.781"
106C-1498	6.500"
106C-1544	7.000"
330601-1	6.250"

CR-2 LONG SHAFT (Cont'd)

Part No.	Type	Length
106C-1083	RS-8	7.969"
106C-1094	RS-8	8.469"
106C-1123	RS-8	12.968"
106C-1169	RS-8	9.125"
106C-1315	RS-8	7.625"
106C-1367	RS-8	10.312"
106C-1375	RS-8	6.781"
106C-1417	RS-8	7.250"
106C-1422	RS-8	7.500"
106C-1490	RS-8	16.000"
106C-1515	RS-5	11.375"
106C-1529	RS-5	8.312"
330610-5	RS-8	9.469"
330610-11	RS-8	10.750"
46-510-9	RS-5	7.125"
330610-10	RS-8	9.500"



CR-2 LONG SHAFT

Part No.	Type	Length
106C-438	RS-5	14.000"
106C-588	RS-5	7.000"
106C-617	RS-8	10.469"
106C-839	RS-8	11.469"
106C-939	RS-8	10.000"
106C-953	RS-8	9.750"
106C-959	RS-8	11.968"
106C-960	RS-8	8.719"
106C-1046	RS-8	8.968"
106C-1047	RS-8	9.469"

CR-6 PEDAL ADJ. ARM

- 310233X For Left Side Mtg.
- 310473X For Right Side Mtg.
- 47-526-1-1X* Lever Type 7/4"
- 310873X* Lever Type 7/4"
- *Lever type can be used on either right or left side.

THRU SHAFT (used with Push Type Clutch)

Part No.	Type	Length
106C-1566	Splined	19.125"
106C-1550	Keyed	16.375"
106C-1558	Keyed	19.000"
106C-1578	Splined	19.500"
49-510-1	Keyed	19.120"
97-510-2	Splined	19.313"

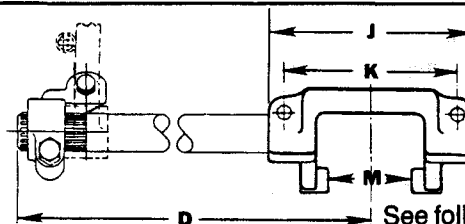

See following page for "D" dimensions.

CLUTCH RELEASE YOKES

CR-7	Forging No.	Used With	Type	J	K	M
105C-64	F105C64	Spicer 15 1/2" SP	Pull	8.000"	6.500"	4.895"
105C-68	F105C99	Spicer 14" SP	Pull	7.125"	5.750"	4.132"
105C-117 ¹	F105C118	Spicer & Others	Push	8.375"	7.000"	4.885"
105C-124 [■]	F105C125	Spicer AL & AR	Push	3.750"	2.125"	2.885"
105C-132 ²	F105C118	Spicer & Others	Push	8.375"	7.000"	4.885"
105C-137	F105C138	Spicer 13" and	Pull	8.000"	6.500"	4.895"
	C105C138	14" 2P				
85-509-3 ³	F105C118	Spicer & Others	Push	8.375"	7.000"	4.885"

¹Machined washer surface on yoke front
²Machined washer surface on yoke rear (for clearance)
³Same as ¹ above except contains spring holes in lugs
[■]Use 7743X Clutch Release Bearing and (2) 2306-12 Springs.

★ CLUTCH RELEASE YOKE ATTACHING PARTS—
 Use one KEY 10-30, two SCREWS 330231 and two LOCK WASHERS 500356-12
 NOTE: When changing from a two plate to single plate clutch or vice versa, a different bearing cap will be required.

**MODEL ES62-5
BASIC OVERHAUL KITS**



T210-ES62-5

Part Number	Part Description	Qty.
313400-68X	Major Overhaul Kit	1
500008-37	Woodruff Key - #F	4
53-205-1	Washer - Mainshaft	1
501200	Nut - Mainshaft	1
313401-13X	Thrust Washer Kit	1
313429-6X	Shifter Housing Repair Parts Kit	1
313432-31X	Minor Overhaul Kit	1
313432-31X	Minor Overhaul Kit	1
	Bearings	
550375	Countershaft - cup	2
550927	Countershaft - cone	2
550886	Reverse idler shaft	2
550929	Drive gear and Mainshaft rear - cup	2
550930	Drive gear and Mainshaft rear - cone	2
550931	Drive gear - pocket	1
550932	1st and Reverse mainshaft needle bearing assy.	2
59-482-1-1X	Needle roller bearing and spacer kit	1
60-463-8	Oil Seal - mainshaft rear	1
60-463-10-1X	Oil Seal - drive gear	1
63-463-1	Oil Seal - mainshaft rear (Ford only)	1
545007	Bearing Lubricant	1
545080-1	Loctite	1
2770	Bearing Lube instructions	1
2783	Loctite Application instructions for Mainshaft nut	1
47-228-1-1	Adjusting Shim - mainshaft rear	9
47-228-2-2	Shim - mainshaft front	1
47-228-2-10	Spacer - mainshaft rear	1
312475-28X	Gasket Kit	1
313024-18X	Snap Ring Kit	1
313438X	Shim Kit - countershaft rear	1
59-482-1-1X		
2360	Service Manual	1
No. 2	Spicer Service Topics	1
	(Included in Major Overhaul Kit)	
313401-13X	Thrust Washer Kit	1
974-W	Countershaft - reverse idler	2
1016-W	Mainshaft - 4th speed	1
330818	Mainshaft - 3rd and 4th speed	1
330866	Mainshaft - 1st speed	1
330867	Mainshaft - reverse	1



**MODEL ES62-5
BASIC OVERHAUL KITS**

T210-ES62-5

Part Number	Part Description	Qty.
(Included in Major Overhaul Kit)		
313429-6X	Shifter Housing Repair Parts Kit	1
277-SP	Interlock Pin	1
50-80-1	Ball - shift rod poppet and interlock	7
50-80-4	Ball - backup switch	2
62-438-2	Plunger - 1st and reverse	2
47-72-1	Spring - shift rod poppet	3
62-72-8	Spring - shift finger plunger 1st and reverse	1
(Included in Major and Minor Overhaul Kits)		
312475-28X	Gasket Kit	1
82-118-1	Remote Control - aperture cover	1
47-155-1	Shifter Housing	1
62-155-13	Control cover	1
47-223-1	Drive Gear Bearing Cap	1
47-223-2	Countershaft Rear Bearing Cap	1
47-223-3	Mainshaft Rear Bearing Cap	1
47-223-4	Mainshaft Rear Bearing Cap - for brake mounting	1
47-223-5	Countershaft Front Bearing Cap	1
53-223-1	Mainshaft Rear Bearing Cap - for brake mounting	1
63-223-7	Mainshaft Rear Bearing Cap - for Ford only	1
47-352-1	Clutch Housing	1
97-324-1-1X	P.T.O. (6 holes) Kit	1
97-324-2-1X	P.T.O. (8 holes) Kit	1
313024-18X	Snap Ring Kit	1
27-381-5	Mainshaft	2
46-381-1	Countershaft and Mainshaft	2
53-381-2	Mainshaft	2
59-381-2	Countershaft 4th speed	
313438X	Shim Kit - countershaft rear	1
47-228-3-1	Shim - rear bearing	4
2759	Bulletin - drive gear replacement	1
2789	Bulletin - baffle and shim kit	1

**MODEL ES62-5
TABULATED BILLS OF MATERIAL**



T210-ES62-5

Tab No.	Used by	For Use With Clutch	S A E	Clutch Housing	Rel. Code Pages 10-11	Drive Gear A-1	Drive Gear Bearing Cap F-2	Case Assembly G-1
				Assembly Number				
Model ES62-5A								
301528								
-1	Navistar	Pull Type	2	47-518-4-1X	-	67-35-2-1X	53-19-11-1X	59-15-7-2X
-2	Navistar	Pull Type	2	47-518-4-1X	-	67-35-2-1X	53-19-11-1X	59-15-9-2X
Model ES62-5D								
301530								
-1	Navistar	Pull Type	2	47-518-4-1X	-	67-35-2-1X	53-19-11-1X	59-15-9-2X
-2	Navistar	Pull Type	2	47-518-4-1X	-	67-35-2-1X	53-19-11-1X	59-15-9-2X



**MODEL ES62-5
TABULATED BILLS OF MATERIAL**

T210-ES62-5

Tab No.	Mainshaft Rear Brg. Cap Assembly H-1 (Includes Bushing & Seal)	SPEEDOMETER		End Yoke or Companion Flange Page 12	SHIFTER		
		Drive Gear Signal Gear B-24	Driven Gear h-7		Housing Assy. Pages 14-15	Lever & Dome Page 19	Remote Control Pages 16-17
Model ES62-5A							
301528							
-1	53-19-26-2X	53-452-5	-	-	47-16-1-8X	-	-
-2	53-19-24-2X	53-452-5	-	-	47-16-1-8X	-	-
Model ES62-5D							
301530							
-1	53-19-24-2X	53-452-5	-	-	47-16-1-8X	-	-
-2	53-19-26-2X	53-452-5	-	-	47-16-1-8X	-	-

For parts or service call us
Pro Gear & Transmission, Inc.



1 (877) 776-4600

(407) 872-1901

parts@eprogear.com

906 W. Gore St.

Orlando, FL 32805

